



**YAMAHA**

# **How to Fix your YAMAHA two cylinder, two-stroke motorcycle**

**90 and 100cc: YL1, HS1, LS2**

**125, 180 and 200cc: YCS1, YAS1, AS2, CS3, CS5, RD200A**

**250, 305 and 350cc: YDS-3, YM-1, TD-1, YDS-5, YM2C, DS6, YR-1,  
YR-2, R-3, R3-RR, DS-7, R5, RD250, RD350**

# CONTENTS

## DESIGN FUNDAMENTALS

Carburetors .....	5
Engine Types .....	3
Ignition Systems .....	7
Spark Plug Design .....	8
Spark Plug Identification—	
AC .....	9
Bosch .....	9
Champion .....	10
NGK .....	10

## SERVICE SECTION

Yamaha—	
90 and 100cc .....	11
125, 180 and 200cc .....	16
YDS-3 and YM-1 .....	22
TD-1 .....	26
YDS-5, YM2C and DS6 .....	28
YR-1, YR-2 and R-3 .....	33
R3 RR .....	38
DS-7, RD250 and RD350 .....	39

## SERVICE FUNDAMENTALS

Battery Ignition .....	47
Brakes .....	55
Capacitor Discharge Ignition .....	49
Carburetor .....	46
Chain .....	56
Clutch Control .....	51
Connecting Rod and Crankshaft .....	55
Crankcase and Gear Box .....	55
Disassembly and Assembly .....	51
Energy Transfer Ignition .....	49
Fastener Threads .....	53
Flywheel Magneto .....	48
Generating Systems .....	50
Lubrication .....	51
Piston, Rings and Cylinder .....	53
Repairing Damaged Threads .....	52
Spark Plug .....	45
Speed Tuning .....	58
Trouble Shooting .....	44
Unit Magneto .....	48
Wire Wheels .....	57

GLOSSARY OF TERMS .....	64
-------------------------	----

DEGREE WHEEL .....	88
--------------------	----

# ENGINE DESIGN FUNDAMENTALS

## OPERATING PRINCIPLES

### ENGINE TYPES

The engines used to power motorcycles and many other items of power equipment in use today are basically similar. All are technically known as "Internal Combustion Reciprocating Engines."

The source of power is heat, formed by the burning of a combustible mixture, usually petroleum products and air. In a reciprocating engine, this burning takes place in a closed cylinder containing a piston. Expansion resulting from the heat of combustion applies pressure on the piston to turn a shaft by means of a crank and connecting rod.

The fuel-air mixture may be ignited by means of an electric spark (Otto Cycle Engine) or by heat formed from compression of air in the engine cylinder (Diesel Cycle Engine). The complete series of events which must take place in order for the engine to run may occur in one revolution of the crankshaft (two strokes of the piston in cylinder) which is referred to as a "Two-Stroke Cycle Engine," or in two revolutions of the crankshaft (four strokes of the piston in cylinder) which is referred to as a "Four-Stroke Cycle Engine."

**OTTO CYCLE.** In a spark ignited engine, a series of five events is required in order for the engine to provide power. This series of events is called the "Cycle" (or "Work Cycle") and is repeated in each cylinder of the engine as long as work is being done. This series of events which comprise the "Cycle" is as follows:

1. The mixture of fuel and air is pushed into the cylinder by atmospheric pressure when the pressure within the engine cylinder is reduced by the piston moving downward in the cylinder (or by applying pressure to the fuel-air mixture as by crankcase compression in the crankcase of a "Two-Stroke Cycle Engine" which is described in a later paragraph).

2. The mixture of fuel and air is compressed by the piston moving upward in the cylinder.

3. The compressed fuel-air mixture is ignited by a timed electric spark.

4. The burning fuel-air mixture expands, forcing the piston downward in the cylinder thus converting the chemical energy generated by combustion into mechanical power.

5. The gaseous products formed by the burned fuel-air mixture are exhausted from the cylinder so that a new "Cycle" can begin.

The above described five events which comprise the work cycle of an engine are commonly referred to as (1), INTAKE; (2), COMPRESSION; (3), IGNITION; (4) EXPANSION (POWER); and (5), EXHAUST.

**TWO STROKE CYCLE.** Two stroke cycle engines may be of the Otto Cycle (spark ignition) or Diesel Cycle (compression ignition) type. However, since the two-stroke cycle engines listed in the repair section of this manual are all of the Otto Cycle type, operation of two-stroke Diesel Cycle engines will not be discussed in this section.

In two-stroke cycle engines, the piston is used as a sliding valve for the cylinder intake and exhaust ports. The intake and exhaust ports are both open when the piston is at the bottom of its downward stroke (bottom dead center or "B.D.C.") The exhaust port is open to atmospheric pressure; therefore, the fuel-air mixture must be elevated to a higher than atmospheric pressure in

order for the mixture to enter the cylinder. As the crankshaft is turned from B.D.C. and the piston starts on its upward stroke, the intake and exhaust ports are closed and the fuel-air-mixture in the cylinder is compressed. When the piston is at or near the top of its upward stroke (top dead center or "T.D.C."), an electric spark across the electrode gap of the spark plug ignites the fuel air mixture. As the crankshaft turns past T.D.C. and the piston starts on its downward stroke, the rapidly burning fuel-air mixture expands and forces the piston downward. As the piston nears bottom of its downward stroke, the cylinder exhaust port is opened and the burned gaseous products from combustion of the fuel-air mixture flows out the open port. Slightly further downward travel of the piston opens the cylinder intake port and a fresh charge of fuel-air mixture is forced into the cylinder. Since the exhaust port remains open, the incoming flow of fuel-air mixture helps clean (scavenge) any remaining burned gaseous products from the cylinder. As the crankshaft turns past B.D.C. and the piston starts on its upward stroke, the cylinder intake and exhaust ports are closed and a new cycle begins.

Since the fuel-air mixture must be elevated to a higher than atmospheric pressure to enter the cylinder of a two-stroke cycle engine, a compressor pump must be used. Coincidentally, downward movement of the piston decreases the volume of the engine crankcase. Thus, a compressor pump is made available by sealing the engine crankcase and connecting the carburetor to a port in the crankcase. When the piston moves upward, volume of the crankcase is increased which lowers pressure within the crankcase to below atmospheric. Air will then be forced through the carburetor, where fuel is mixed with the air, and on into the engine crankcase. In order for downward movement of the piston to compress the fuel-air mixture in the crankcase, a valve must be provided to close the carburetor to crankcase port. Three different types of valves are used. In Fig. 1-1, a reed type inlet valve is shown in the schematic diagram of the two-stroke cycle engine. Reeds (R) are forced open by atmospheric pressure as shown in view "B" when the piston is

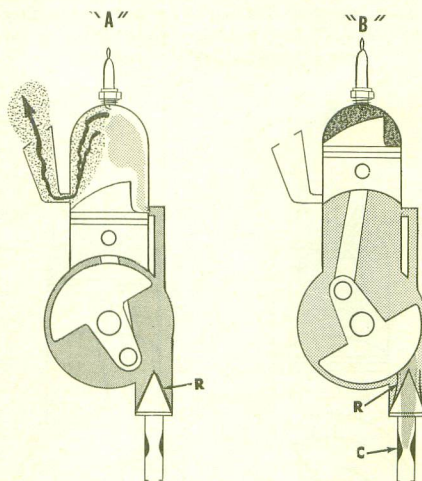

*Fig. 1-1—Schematic diagram of a two-stroke cycle engine operating on the Otto Cycle (spark ignition). View "B" shows piston near top of upward stroke and atmospheric pressure is forcing air through carburetor (C), where fuel is mixed with the air, and the fuel-air mixture enters crankcase through open reed valve (R). In view "A", piston is near bottom of downward stroke and has opened the cylinder exhaust and intake ports; fuel-air mixture in crankcase has been compressed by downward stroke of engine and flows into cylinder through open port. Incoming mixture helps clean burned exhaust gases from cylinder.*

on its upward stroke and pressure in the crankcase is below atmospheric. When the piston reaches T.D.C., the reeds close as shown in view "A" and fuel-air mixture is trapped in the crankcase to be compressed by downward movement of the piston. In Fig. 1-2, a schematic diagram of a two-stroke cycle engine is shown in which the piston is utilized as a sliding carburetor-crankcase port (third port) valve. In Fig. 1-3, a schematic diagram of a two-stroke cycle engine is shown in which a slotted disc (rotary valve) attached to the engine crankshaft opens the carburetor-crankcase port when the piston is on its upward stroke. In each of the three basic designs shown, a transfer port (TP—Fig. 1-2) connects the crankcase compression chamber to the cylinder; the transfer port is the cylinder intake port through which the compressed fuel-air mixture in the crankcase is transferred to the cylinder when the piston is at bottom of stroke as shown in view "A."

Due to rapid movement of the fuel-air mixture through the crankcase, the crankcase cannot be used as a lubricating oil sump because the oil would be carried into the cylinder. Lubrication is accomplished by mixing a small amount of oil with the fuel or by a separate oil metering system. In either case, the engine lubricating oil is carried through the crankcase and eventually is forced into the combustion chamber where it is burned. Where an oil metering system is used, ratio of oil to fuel by volume is varied by throttle opening and engine speed. When oil is pre-mixed with the fuel, manufacturer's recommended fuel-oil ratio should be strictly observed.

**FOUR-STROKE CYCLE.** In a four-stroke cycle engine operating on the Otto Cycle (spark ignition), the five

events of the cycle take place in four strokes of the piston, or in two revolutions of the engine crankshaft. Thus, a power stroke occurs only on alternate downward strokes of the piston.

In view "A" of Fig. 1-4, the piston is on the first downward stroke of the cycle. The mechanically operated intake valve has opened the intake port and, as the downward movement of the piston has reduced the air pressure in the cylinder to below atmospheric pressure, air is forced through the carburetor, where fuel is mixed with the air, and into the cylinder through the open intake port. The intake valve remains open and the fuel-air mixture continues to flow into the cylinder until the piston reaches the bottom of its downward stroke. As the piston starts

on its first upward stroke, the mechanically operated intake valve closes and, since the exhaust valve is closed, the fuel-air mixture is compressed as in view "B."

Just before the piston reaches the top of its first upward stroke, a spark at the spark plug electrodes ignites the compressed fuel-air mixture. As the engine crankshaft turns past top center, the burning fuel-air mixture expands rapidly and forces the piston downward on its power stroke as shown in view "C." As the piston reaches the bottom of the power stroke, the mechanically operated exhaust valve starts to open and as the pressure of the burned fuel-air mixture is higher than atmospheric pressure, it starts to flow out the open exhaust port. As the engine crankshaft turns past bottom center, the exhaust valve is almost completely open and remains open during the upward stroke of the piston as shown in view "D." Upward movement of the piston pushes the remaining burned fuel-air mixture out of the exhaust port. Just before the piston reaches the top of its second upward or exhaust stroke, the valve opens and the exhaust valve closes. The cycle is completed as the crankshaft turns past top center and a new cycle begins as the piston starts downward as shown in view "A."

In a four-stroke cycle engine operating on the Diesel Cycle, the sequence of events of the cycle is similar to that described for operation on the Otto Cycle, but with the following exceptions: On the intake stroke, air only is taken into the cylinder. On the compression stroke, the air is highly com-

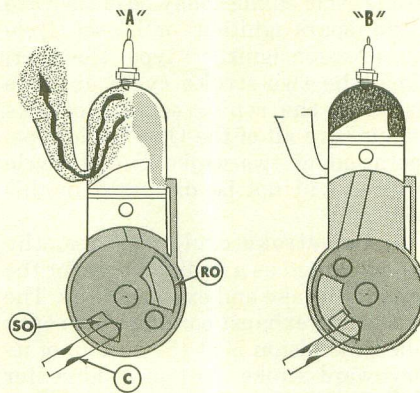

Fig. 1-3—Schematic diagram of two-stroke cycle engine similar to those shown in Figs. 1-1 and 1-2 except that a rotary carburetor to crankcase port valve is used. Disc driven by crankshaft has rotating opening (RO) which uncovers stationary opening (SO) in crankcase when piston is on upward stroke. Carburetor is (C).

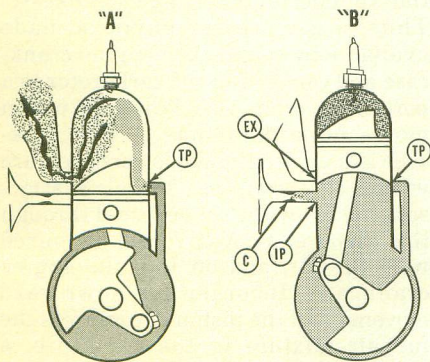

Fig. 1-2—Schematic diagram of two-stroke cycle engine operating on Otto Cycle. Engine differs from that shown in Fig. 1-1 in that piston is utilized as a sliding valve to open and close intake (carburetor to crankcase) port (IP) instead of using reed valve (R—Fig. 1-1).

C. Carburetor  
EX. Exhaust port  
IP. Intake port (carburetor to crankcase)  
TP. Transfer port (crankcase to cylinder)

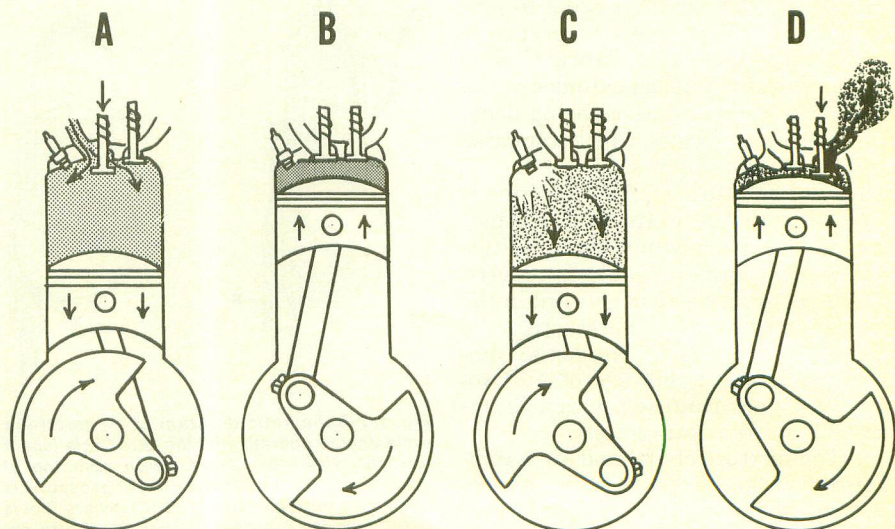

Fig. 1-4—Schematic diagram of four-stroke cycle engine operating on the Otto (spark ignition) cycle. In view "A", piston is on first downward (intake) stroke and atmospheric pressure is forcing fuel-air mixture from carburetor into cylinder through the open intake valve. In view "B", both valves are closed and piston is on its first upward stroke compressing the fuel-air mixture in cylinder. In view "C", spark across electrodes of spark plug has ignited fuel-air mixture and heat of combustion rapidly expands the burning gaseous mixture forcing the piston on its second downward (expansion or power) stroke. In view "D", exhaust valve is open and piston on its second upward (exhaust) stroke forces the burned mixture from cylinder. A new cycle then starts as in view "A."

pressed which raises the temperature of the air. Just before the piston reaches top dead center, fuel is injected into the cylinder and is ignited by the heated, compressed air. The remainder of the cycle is similar to that of the Otto Cycle.

**CARBURETORS**

Function of the carburetor on a spark-ignition engine is to atomize the fuel and mix the atomized fuel in proper proportions with air flowing to the engine intake port or intake manifold. Carburetors used on engines that are to be operated at constant speeds and under even loads are of simple design since they only have to mix fuel and air in a relatively constant ratio. On engines operating at varying speeds and loads, the carburetors must be more complex because different fuel-air mixtures are required to met the varying demands of the engine.

**Requirements**

To meet the demands of an engine being operated at varying speeds and loads, the carburetor must mix fuel and air at different mixture ratios. Gasoline-air mixture ratios required for different operating conditions are approximately as follows:

	Fuel	Air
Starting, cold weather	1 lb.	7 lbs.
Accelerating	1 lb.	9 lbs.
Idling (no load)	1 lb.	11 lbs.
Part open throttle	1 lb.	15 lbs.
Full load, open throttle	1 lb.	13 lbs.

**Basic Design**

Carburetor design is based on the venturi principle which simply means

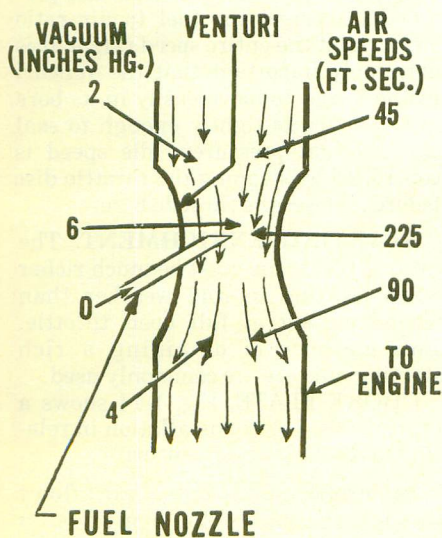

Fig. 1-5—Drawing illustrating the venturi principle upon which carburetor design is based. Figures at left are inches of mercury vacuum and those at right are air speeds in feet per second that are typical of conditions found in a carburetor operating at wide open throttle. Zero vacuum in fuel nozzle corresponds to atmospheric pressure.

that a gas or liquid flowing through a necked-down section (venturi) in a passage undergoes an increase in velocity (speed) and a decrease in pressure as compared to the velocity and pressure in full size sections of the passage. The principle is illustrated in Fig. 1-5, which shows air passing through a carburetor venturi. The figures given for air speeds and vacuum are approximate for a typical wide-open throttle operating condition. Due to low pressure (high vacuum) in the venturi, fuel is forced out through the fuel nozzle by the atmospheric pressure (0 vacuum) on the fuel; as fuel is emitted from the nozzle, it is atomized by the high velocity air flow and mixes with the air.

Although some carburetors may be very basic, the varying requirements of motorcycle engines make it necessary to incorporate features to provide variable fuel-air ratios for different operating conditions. These design features will be described in the following paragraphs which outline the different carburetor types.

**Carburetor Types**

Carburetors used on motorcycles are usually classified by type of throttle valve, venturi and starting (enriching) method used. The following paragraphs describe the different operating principles. Various combinations of the following features are used in each motorcycle carburetor.

**THROTTLE VALVES.** In order to vary the speed, a valve is installed between the fuel nozzle and engine which limits the volume of combustible mixture available to the combustion chamber. When less mixture is available to the combustion area, there will be less expansion resulting in less rpm and less power. The two types of throttle valves commonly used are the disc (butterfly) valve (Fig. 1-6) and the variable venturi (slide) valve (Fig. 1-9).

If, after the engine has been started, the throttle valve is in the wide-open position, the engine can obtain enough fuel and air to run at dangerously high speeds so the throttle valve must be partly closed. At no load, the engine requires very little air and fuel to run at its rated speed and the throttle must be moved nearer the closed position. As more load is placed on the engine, more fuel and air mixture is required for the engine to operate at its rated speed. When the engine is required to develop maximum power or speed, the throttle must be in the wide open position.

**DISC (BUTTERFLY) VALVE.** A typical disc type throttle valve is shown in Figs. 1-6, 1-7 and 1-8. As the throttle disc is turned, the opening of the throttle bore is decreased. When

disc is in position shown in Fig. 1-8, the throttle opening is nearly closed. Idle speed adjustment is accomplished by stopping rotation of the valve before throttle bore is completely closed. When throttle is nearly closed, vacuum at the venturi is insufficient to provide correct fuel-air ratio by using only one fuel nozzle. Usually an additional idle jet (Fig. 1-8) and intermediate jet (Fig. 1-7) are incorporated.

**VARIABLE VENTURI (SLIDE) VALVE.** A typical slide type carburetor is shown in Fig. 1-9. When the slide is completely open, the small step in the throttle bore serves as a large diameter venturi for high speed. As the slide is lowered, the venturi size is decreased as shown in Fig. 1-10. Decreasing the venturi size slows the speed by decreasing the amount of fuel and air mixture that can be drawn into the engine and also increases the vacuum at the venturi fuel nozzle. A valve needle attached to the throttle slide is incorporated to lower the amount of fuel drawn in by the high

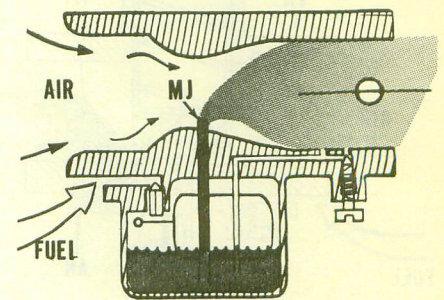

Fig. 1-6—View of carburetor showing disc type throttle valve completely open for high speed operation.

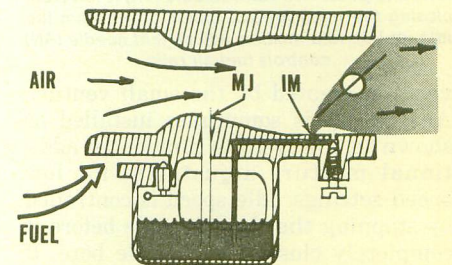

Fig. 1-7—As disc type throttle valve is moved toward the closed position, vacuum at the main jet (MJ) may not be enough to draw fuel into the passing air and an intermediate jet (IM) is provided.

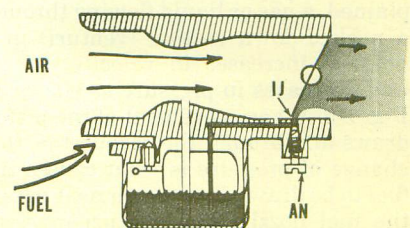

Fig. 1-8—With throttle disc nearly closed, the idle jet (IJ) is used. Usually an adjustment needle (AN) is provided to adjust the idle mixture fuel-air ratio.

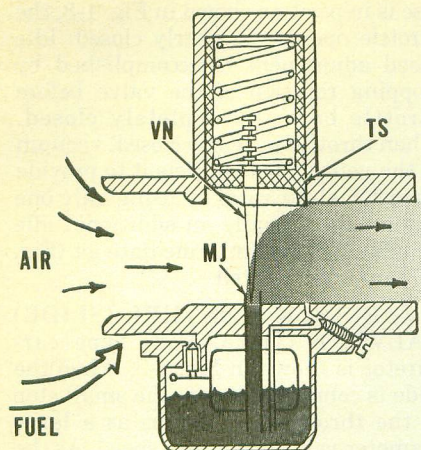

Fig. 1-9-View of variable venturi, slide type throttle valve. Throttle slide (TS) is in the fully raised high speed position. Valve needle (VN) is raised allowing main jet (MJ) to be completely open.

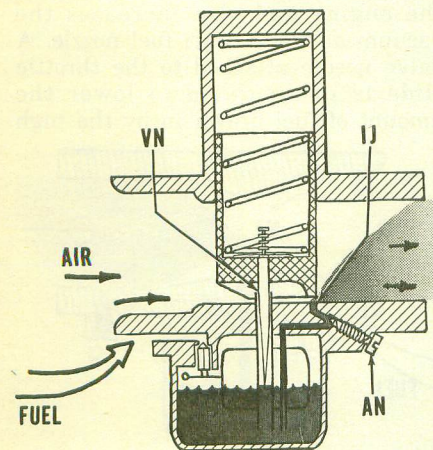

Fig. 1-10-With throttle slide lowered to idle speed position, only a small amount of air is allowed to pass. The valve needle (VN) is lowered, closing the main jet and fuel is drawn from the idle jet (IJ). Idle mixture adjustment needle (AN) controls fuel-air ratio.

vacuum created by the small venturi. An idle jet is sometimes installed as shown in Fig. 1-10 to provide an additional mixture adjustment for low speed settings. Idle speed is controlled by stopping the throttle slide before it completely closes the throttle bore. If the valve needle is raised in the throttle slide, it will increase the fuel flow from the main nozzle at intermediate throttle settings.

**VENTURI.** As previously explained, a gas or liquid flowing through a necked-down section (venturi) in a passage increases in velocity (speed) and decreases in pressure as shown in Fig. 1-5. When movement of the piston draws air through the carburetor, this change of pressure is what causes the fuel to be drawn into the air as it passes the fuel nozzle. The venturi must be matched to the engine to provide the right amount of pressure drop at the venturi for correct fuel-air mixture. Some adjustment can be accomplished

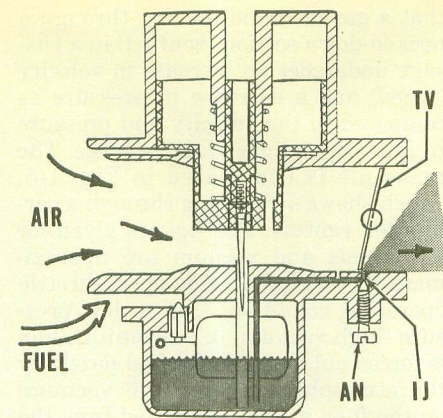

Fig. 1-11-View of vacuum controlled variable venturi type carburetor with throttle valve (TV) nearly closed. Idle mixture adjustment needle (AN) is shown. Fuel is discharged from idle jet (IJ).

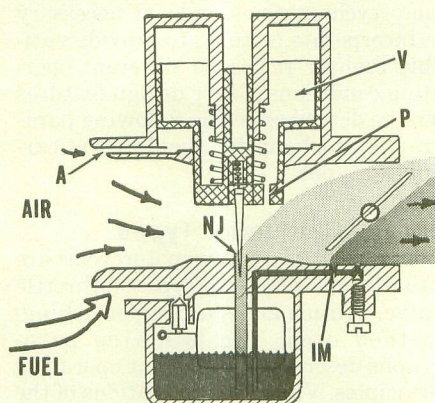

Fig. 1-12-At intermediate throttle setting, atmospheric air pressure is allowed to enter port (A) under the venturi piston and venturi vacuum is transferred to top of piston (V) via port (P). The vacuum above the piston and atmospheric pressure below, causes the venturi piston to raise. Fuel is discharged at partially open needle jet (NJ) and intermediate jet (IM).

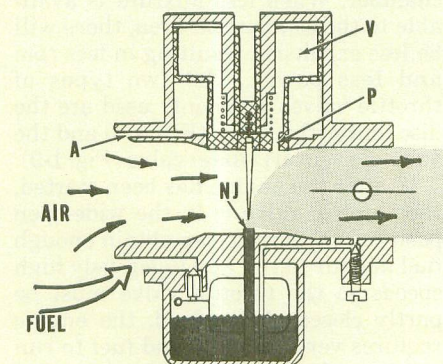

Fig. 1-13-As engine speed and throttle opening are increased, vacuum at venturi port (P) and above venturi piston (V) increases until venturi is completely open. Needle jet (NJ) is completely open.

by making the fuel flow less (or more) restricted by changing the jet sizes; however, manufacturer's recommendation of carburetor and jet sizes should be closely followed.

**VARIABLE VENTURI (SLIDE) VALVE.** The sliding variable venturi that is commonly used as a throttle is explained in a previous paragraph. If a

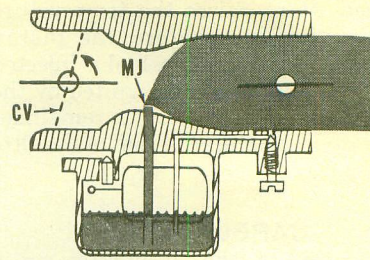

Fig. 1-14-As choke valve (CV) is closed as shown by the broken lines, vacuum is increased at main jet (MJ).

larger carburetor of this same type is installed, it is possible that low speed (part throttle) operation will function normally, but at full open throttle the venturi will be too large to provide the correct fuel-air mixture.

**VACUUM CONTROLLED VENTURI.** Some models utilize a vacuum controlled, variable venturi as shown in Fig. 1-11. These models use a disc type throttle plate which controls the amount of fuel-air mixture available to the engine. When the engine is running at slow speed (throttle nearly closed) the venturi piston is lowered as shown in Fig. 1-11. As the throttle disc is opened Fig. 1-12 and 1-13 the vacuum at the venturi is transferred into chamber (V) via port (P) and atmospheric pressure is admitted under venturi piston via port (A). The high pressure below the venturi and low pressure above causes the piston to raise as shown in Figs. 1-12 and 1-13. As with the slide type variable venturi, a valve needle is attached to the venturi to limit the amount of fuel drawn from the main nozzle at low speed. An idle mixture jet (IJ—Fig. 1-11) and intermediate jet (IM—Fig. 1-12) are provided to correct the fuel to air ratio throughout the entire speed range. It is extremely important that the venturi piston is free to move easily in its bore and that it fits tightly enough to seal the different pressures. Idle speed is controlled by stopping the throttle disc before it closes the throttle bore.

**STARTING ENRICHMENT.** The ratio of fuel to air must be much richer when starting in cold weather than when running at full open throttle. Two methods of obtaining a rich starting mixture are commonly used.

**CHOKE PLATE.** Fig. 1-14 shows a typical choke plate installation in relation to the carburetor venturi.

At cranking speeds, air flows through the carburetor venturi at a slow speed; thus, the pressure in the venturi does not usually decrease to the extent that atmospheric pressure on the fuel will force enough fuel from the nozzle. If the choke plate is closed as shown by the broken line in Fig. 1-14, air cannot enter into the carburetor

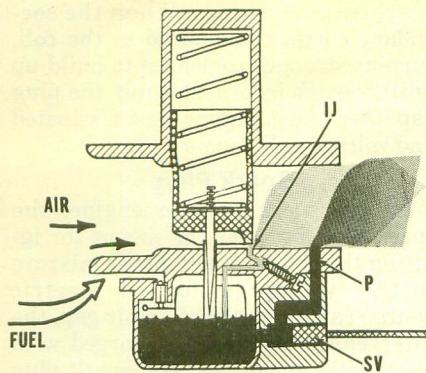

Fig. 1-15—View of simplified starting valve enrichment method. With starting valve (SV) open, the normal idle mixture supplied by idle jet (IJ) is further enriched by starting port (P).

and pressure in the carburetor decreases greatly as the engine is turned at cranking speed. Fuel is then forced from the fuel nozzle. In manufacturing the carburetor choke plate or disc, a small hole or notch is cut in the plate so that some air can flow through the plate when it is in closed position to provide air for the starting fuel-air mixture. In some instances after starting a cold engine, it is advantageous to leave the choke plate in a partly closed position as the restriction of air flow will decrease the air pressure in carburetor venturi, thus causing more fuel to flow from the nozzle resulting in a richer fuel-air mixture. The choke plate or disc should be in fully open position for normal engine operation.

**STARTING VALVE.** Fig. 1-15 shows a simplified starting system typical of the type found in many carburetors. A combination of two principles is utilized to enrich the fuel-air mixture. First, the passage is normally less restricted (larger) than the normal idle passage and second, the starting port is located between the throttle slide and engine. With the starting port (P) located as shown in Fig. 1-15, closing the throttle slide increases the vacuum at the starting port in much the same way as the choke plate previously described. It is obvious that this rich mixture should not normally be used, so a shut-off valve is incorporated in the system. The starter jet shut-off valve (SV—Fig. 1-15) is sometimes actuated by a control on the carburetor; however, is often remote controlled by a handle bar mounted lever via a control cable.

**IGNITION SYSTEM**

The timed spark which ignites the fuel charge in the cylinder may be supplied by either a magneto or battery ignition system. To better understand the operation of the components and

the differences and similarities of the two systems, they will be combined in this section and the functions of the various units explained and compared.

**Theory**

In the modern ignition system, a relatively weak electric current of 6 to 12 volts and 2 to 5 amperes is transformed into a momentary charge of minute amperage and extremely high (10,000-25,000) voltage, capable of jumping the spark plug gap in the cylinder and igniting the fuel charge.

To understand the ignition system theory, electricity can be thought of as a stream of electrons flowing through a conductor. The force of the stream can be increased by restricting volume, or the volume increased by reducing the resistance to movement; but the total amount of power cannot be increased except by employing additional outside force. The current has an inertia of motion and resists being stopped once it has started flowing. If the circuit is broken suddenly, the force will tend to pile up temporarily, attempting to convert the speed of flow into energy.

A short list of useful electrical terms and a brief explanation of their meanings is as follows:

**AMPERE.** The unit of measurement used to designate the amount, or quantity of flow of an electrical current.

**OHM.** The unit of measurement used to designate the resistance of a conductor to the flow of current.

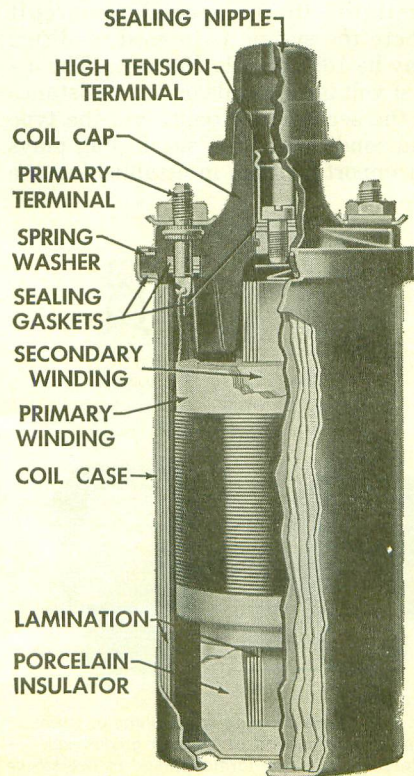

Fig. 1-16—Sectional view of a typical ignition coil.

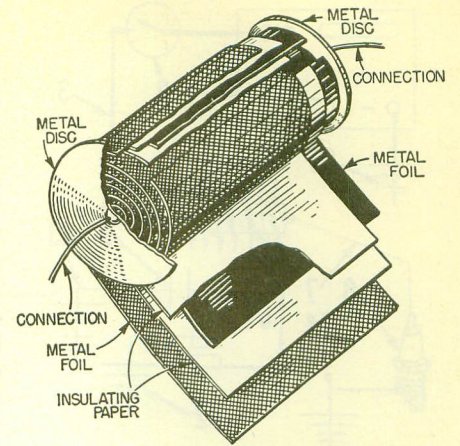

Fig. 1-17—A typical condenser consists of two metal conductors separated by layers of insulating paper and rolled into a tight cylinder.

**VOLT.** The unit of measurement used to designate the force, or pressure of an electrical current.

**WATT.** The unit of measurement which designates the ability of an electrical current to perform work; or to measure the amount of work performed.

The four terms are directly interrelated, one ampere equaling the flow of current produced by one volt against a resistance of one ohm. One watt designates the work potential of one ampere at one volt in one second.

**Ignition Coil**

When an electrical current is flowing through a conductor, a magnetic field exists at right angles to the current flow. As long as the conductor is relatively straight, nothing much happens; but if the conductor is coiled around a soft iron core, then the length of the iron core is at approximately right angles to the wire. A path is provided for the magnetic field and the iron core becomes a magnet as long as the current flows.

A second phenomenon of electrical action is that when a magnetic field is interrupted, a pulsation of electrical energy is formed at right angles to the lines of magnetic flow.

In a battery ignition system, these two peculiarities are combined to form an ignition coil as shown in Fig. 1-16. The inner and outer laminations are composed of soft iron and form a continuous path for a magnetic field. Around the inner laminations but insulated from it, is wound many coils of fine copper wire. Around this coil of fine wire, but insulated from it and the iron core, are fewer turns of heavier copper wire. These windings are encased in the outer laminations, then in a protective case.

The outer winding of heavier wire is connected to the two screw terminals on the coil case and form the primary

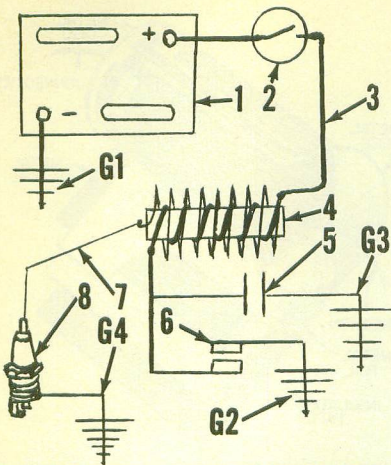

Fig. 1-18—Diagram of a typical battery ignition system. Refer to text for principles of operation.

- 1. Battery
- 2. Ignition switch
- 3. Primary circuit
- 4. Ignition coil
- 5. Condenser
- 6. Contact points
- 7. Secondary circuit
- 8. Spark plug
- G1 thru G4. Ground connections

circuit of the coil. The inner winding of fine wire is grounded at one end while the other end is connected to the insulated, high tension terminal and forms the secondary circuit.

**Primary Circuit**

The primary circuit is attached to the power source in both the battery and magneto electrical system.

In the battery system, the primary circuit consists of the battery, ignition switch, primary windings, contact points, condenser, and the necessary connecting wiring as shown at (3—Fig. 1-18). When the ignition switch (2) and contact points (6) are closed, the primary circuit (3), primary windings of coil (4) and the closed contact points (6), the ground connections (G1 at battery and G2 at points) plus the engine casting or frame, complete the circuit. As the current flows, a magnetic field is built up in the soft iron laminations of coil (4), which is surrounded by the primary and secondary windings. When contact points (6) open to break the circuit, the current tries to flow through the path of least resistance which is the condenser (5) until condenser capacity is reached; then, the primary current ceases to flow and the magnetic field starts to collapse. This collapse is hastened by the condenser, which tries to discharge its stored energy backward through the primary circuit. When the magnetic field collapses, extremely high voltage is induced in the coil secondary windings which flows through secondary circuit (7) to spark plug (8), where it jumps the plug gap and is dissipated in the engine frame through ground (G4).

In a magneto ignition system, the same principles are involved but the method of application is somewhat different. Instead of stored chemical en-

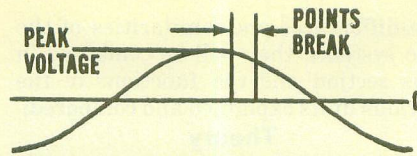

Fig. 1-19—The primary current of a magneto ignition system is an alternating current, thus voltage varies from zero to a predetermined peak during each positive and negative cycle. To produce an adequate spark to ignite the fuel charge, the contact points must break at or near the voltage peak as shown.

ergy of a battery which produces a constant direct current, the source of energy is a pulsating alternating current induced in the magneto primary windings and derived from permanent magnets. Because of variation in voltage and direction of current flow (See Fig. 1-19) the ignition points must not only be correctly timed with relation to the piston, but also to break at or near peak voltage. The proper position with relation to the position of the permanent magnet is decided by laboratory tests and sometimes becomes a part of the service specifications. This position is referred to as "edge gap."

**Secondary Circuit**

The secondary circuit carries the high voltage current from the coil to the spark plug or plugs. The secondary circuit ground at the spark plug should be of negative polarity. On systems with a separate high tension coil, the secondary current polarity can be reversed by changing the primary circuit leads at the coil or by reversing the connections. The potential voltage available in the secondary circuit where the system is in good condition may be 18,000 to 25,000 volts. The actual voltage depends on the resistance of the secondary circuit, and the type and condition of the spark plug plays an important part in establishing the

operating resistance. When the secondary current is induced in the coil, current strength continues to build up until a spark is formed across the plug gap, then the energy will be dissipated and voltage will rise no higher.

**Spark Plug**

In any spark ignition engine, the spark plug provides the means for igniting the compressed fuel-air mixture in the cylinder. Before an electric charge can move across an air gap, the intervening air must be charged with electricity, or ionized. The spark plug gap becomes more easily ionized if the spark plug ground (G4—Fig. 1-18) is of negative polarity. If the spark plug is properly gapped and the system is not shorted, not more than 7,000 volts may be required to initiate a spark. Higher voltage is required as the spark plug warms up, or if compression pressures or the distance of the air gap is increased. Compression pressures are highest at full throttle and relatively slow engine speeds, therefore, high voltage requirements or a lack of available secondary voltage most often shows up as a miss during maximum acceleration from a slow engine speed. There are many different types and sizes of spark plugs which are designed for a number of specific requirements.

**THREAD SIZE.** The threaded, shell portion of the spark plug and the attaching holes in the cylinder are manufactured to meet certain industry established standards. The diameter is referred to as "Thread Size." Those commonly used are: 10MM, 14MM, 18 mm, 7/8 inch and 1/2 inch pipe.

**REACH.** The length of thread, and the thread depth in cylinder head or wall are also standardized throughout the industry. This dimension is mea-

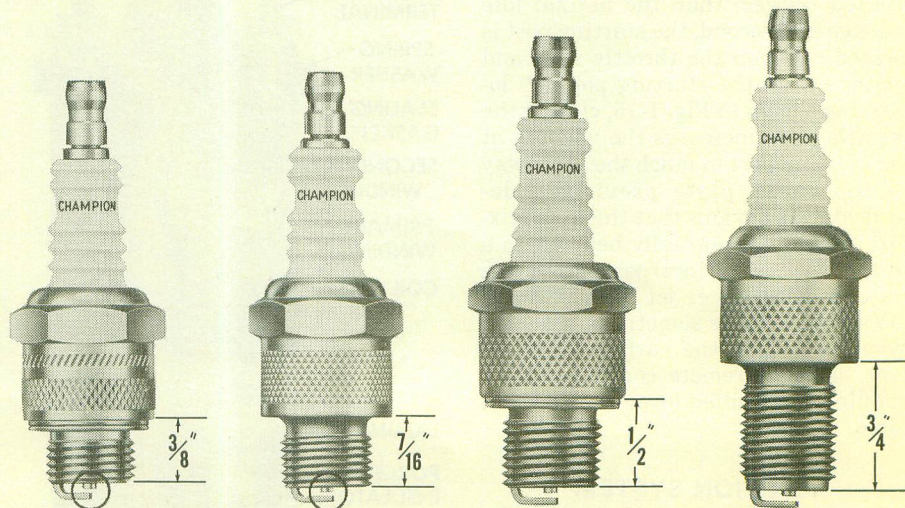

Fig. 1-20—Views showing spark plugs of various "reaches". A 3/8-inch reach spark plug measures 3/8-inch from firing end of shell to gasket surface of shell. The two plugs at left side illustrate the difference in plugs normally used in two-stroke cycle and four-stroke cycle engines; refer to the circled electrodes. Spark plug at left has a shortened ground electrode. The short ground electrode will operate cooler than longer ground electrode.

# FUNDAMENTALS

sured from gasket seat of plug to cylinder end of thread.

**HEAT RANGE.** During engine operation, part of the heat generated during combustion is transferred to the spark plug, and from the plug to the cooling medium through the shell threads and gasket. The operating temperature of the spark plug plays an important part in engine operation. If too much heat is retained by the plug, the fuel-air mixture may be ignited by contact with the heated surface before the ignition spark occurs. If not enough heat is retained, partially burned combustion products (soot, carbon and oil) may build up on the plug tip resulting in "fouling" or shorting out of the plug. If this happens, the secondary current is dissipated uselessly as it is generated instead of bridging the plug gap as a useful spark, and the engine will misfire.

The operating temperature of the plug tip can be controlled, within limits, by altering the length of the path the heat must follow to reach the threads and gasket of the plug. Thus, a plug with a short, stubby insulator around the center electrode will run cooler than one with a long slim insulator. Most plugs in the more popular sizes are available in a number of heat ranges which are interchangeable within the group. The proper heat range is determined by engine design and the type of service. Like most other elements of design, the plug type installed as original equipment is usually a compromise and is either the most suitable plug for average conditions; or the best plug to meet the two extremes of service expected. No one spark plug, however, can be ideally suited for long period of slow-speed operation and still be the best possible type for high-speed operation.

**IDENTIFICATION.** Each spark plug manufacturer uses a different special code to identify spark plug characteristics. It is impossible to provide a plug cross reference chart which is accepted by all manufacturers; however, the following code identification for some spark plugs may be helpful for selecting the correct plug. The plug listed may not be a valid type, but is used for explanation only.

## AC-SPARK PLUGS

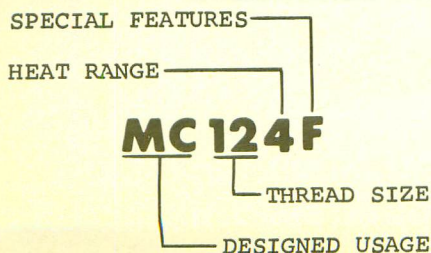
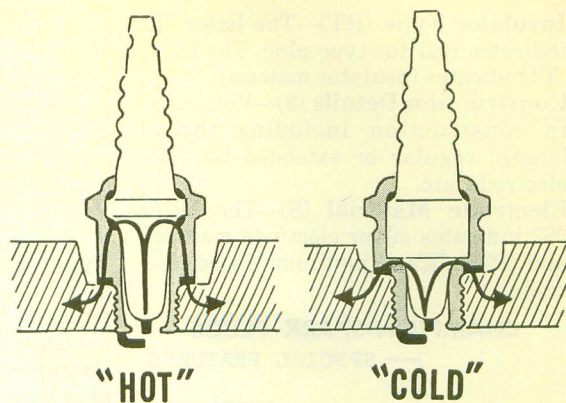

Fig. 1-21—Spark plug tip temperature is controlled by the length of the path heat must travel to reach cooling surface of the engine cylinder head.



**Thread Size (12)**—The first part of numbers indicates thread size. The example "12" indicates that plug thread size is 12MM.

- First number 2 is 1/2 inch thread size.
- First number 4 is 14MM thread size.
- First number 7 is 7/8 inch thread size.
- First number 8 is 18MM thread size.
- First Number 10 is 10MM thread size.
- First number 12 is 12MM thread size.

**Heat Range (4)**—The last number indicates heat range.

- Number 0 or 1 is usually the coldest available in that type of plug. The Example "4" is approximately midrange.
- Last number 9 is extremely hot plug.
- Last number 0 or 1 is extremely cold plug.

**Suffix Letters (F)**—Letter (or letters) after number indicates special features. The "F" in example indicates that plug is "Special reach for Foreign Applications".

- B—Neon tube
- D—Dual side electrodes
- E—Engineer Corps., Shielded (Not an Aircraft type)
- F—Special reach for Foreign Applications
- FF—1/2" reach fully threaded (14MM)
- G—Marine racing gap
- H—Special hex size
- I—Iridium center electrode
- K—Hi-Perf. Marine non-racing gap
- L—Long reach (7/16" for 14MM, 3/4" for 18MM)
- XL—Extra Long reach (3/4" for 14 MM)
- N—Extra long reach (14MM) (3/4" reach with 3/8" thread length)
- P—Platinum electrodes
- R—Resistor
- S—(14MM) Extended tip
- S—(7/8") Moderate long reach (23/32")
- T—Tapered engine seat
- TS—Tapered seat with extended tip
- W—Recessed termination
- X—Special gap
- Y—3 prong cloverleaf electrode

# Spark Plugs

**Prefix Letters (MC)**—Letter (or letters) before numbers indicates designed usage. Many times a standard plug (without MC) will be suitable for motorcycle use and will not be marked "MC."

- B—Series gap
- C—Commercial
- CS—Low profile
- G—Gas engine
- H—High altitude or weatherproof (shield connector, 3/4-20 thread)
- M—Marine
- MC—Motorcycle type
- LM—Lawn mower type
- R—Resistor
- S—Shielded (3/8-24 thread)
- SN—Snow
- TC—Tractor Commercial
- V—Surface Gap
- W—Water proof (shield connector, 3/8-24 thread)

## BOSCH-SPARK PLUGS

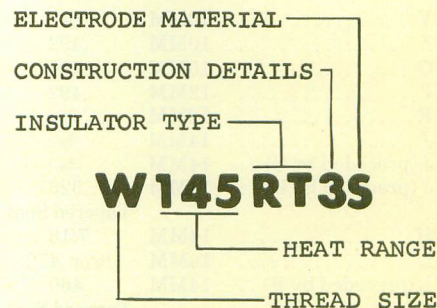

**Thread Size (W)**—The first letter (or letters) indicates thread size and general type of plug. The example "W" is 14MM.

- M, MA, MG, MV, MAG and MGW ..... 18MM
- U ..... 10MM
- W, WD, WG, WK and WKA . 14MM
- X ..... 12MM
- Z ..... 7/8 inch—18

Thread size codes MA and MAG are tapered seat; WK and WKA are short plugs; WD type is surface gap plug.

**Heat Range (145)**—The number indicates plug heat range between 20 (hot) to 340 (cold). Example of "145" is approximately mid-range.

# Spark Plugs

**Insulator Type (RT)**—The letter "R" indicates resistor type plug. The letter "T" indicates insulator material.

**Construction Details (3)**—Variations in construction including thread length; regular or extended tip, side electrode, etc.

**Electrode Material (S)**—The letter "S" indicates silver electrode material and "P" indicates platinum tipped electrode.

## CHAMPION-SPARK PLUGS

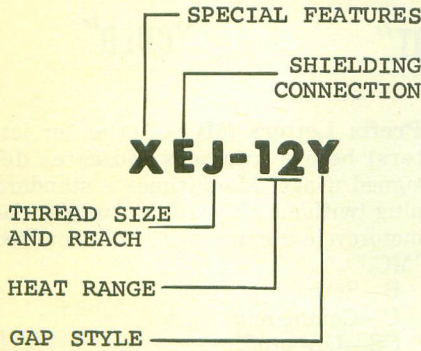

**Heat Range (12)**—The heat range numbers are divided into four types. Number 1-25 are for automotive, marine and ordnance plugs; numbers 26-50 are for aircraft; numbers 51-75 are racing plugs; numbers 76-99 indicate special features or application. On all types, the higher number (within type range) indicates hotter plug.

**Thread Size and Reach (J)**—The code letter "J" in the example indicates 14MM thread size with 3/8 inch reach.

Letter	Thread Size	Thread Reach (Inch)	
Y	10MM	3/4	
Z	10MM	.492	
G	10MM	.700	
P	12MM	.492	
R	12MM	3/4	
J	14MM	3/8	
J (preceded by C)	14MM	3/8	
J (preceded by D)	14MM	.325	Tapered Seat
H	14MM	7/16	
L	14MM	1/2 or .472	
L (preceded by B)	14MM	.460	Tapered Seat
N	14MM	3/4	
N (preceded by B)	14MM	.708	Tapered Seat
E	14MM	.680	
F	18MM	.460	Tapered Seat

D	18MM	1/2
M	18MM	1/2
K	18MM	All
B	18MM	13/16
U	18MM	1 1/2
W	7/8"-18	All
C	7/8"-18	All
S	1 1/8"-12	.600
None	1/2"-14 Pipe Thread	All
V	Model Airplane Engine Plug	

**Type of Shielding Connection (E)**—In some cases indicates special short plugs. If this code is not used, plug is not shielded and is not a short plug. Example "E" indicates shielded spark plug with 5/8 inch—24 threaded connection.

- B—See Thread Size Code L & N
- C—(See thread Size Code J) Short plug, Bantam
- D—(See thread Size Code J) Short plug
- E—Shielded 5/8 inch-24
- H—Shielded 3/4 inch-20
- M—Shielded 5/8 inch-24 Ordinance
- P—Shielded 9/16 inch-27
- S—Shielded 11/16 inch-24 Whitworth
- T—Low Profile plug Shorty
- W—Shielded 13/16 inch-20

**Special Internal Features (X)**—Indicates resistor or auxiliary gap. If this code is not present, plug is not resistor or auxiliary gap type.

- R—Resistor (less than 6000 ohms)
- X—Resistor (more than 6000 ohms)
- U—Auxiliary gap

**Gap Style (Y)**—Suffix letters indicate type of electrodes and type of gap. Letter "Y" in the example indicates projected core ("Turbo-Action") gap style.

- B—Two heavy duty ground electrodes
- C—Protruding nose, Round ground electrode, Sawed gap
- D—Protruding nose, Round ground electrode
- F—Three heavy duty ground electrodes
- G—"Gold Palladium" center electrode
- J—Cut back ground electrode
- LM—Special lawn mower
- N—Four prong aircraft type
- P—Fine wire Platinum electrodes
- R—Push wire ground electrode
- S—Single ground electrode at side of center electrode

# DESIGN FUNDAMENTALS

- T—Keikhaefer Gap
- V—Surface Gap
- Y—Projected core nose

NOTE: The Champion Spark Plug Company suggests using "Gold Palladium" type (suffix G) plug for most motorcycle applications.

## NGK SPARK PLUGS

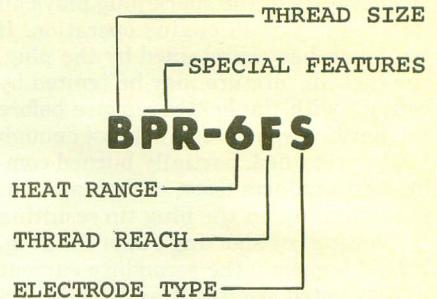

**Thread Size (B)**—The first letter indicates thread size. The second and third letters (if used) indicate variations. Projected insulator plugs are indicated by using "P" as second letter. Resistor plugs are indicated by using "R" and low profile plugs are indicated by "M" as the second or third letter.

- A ..... 18MM
- AB ..... 18MM (13/16 inch Hex)
- B ..... 14MM
- C ..... 10MM
- D ..... 12MM

**Heat Range (6)**—The number indicates the heat range. Numbers are from 2 (hot) to 14 (cold). Number "6" of the example is approximately mid-range.

**Thread Reach**—Three suffix letters (E, H & L) are used to indicate thread reach. If none of the above letters appear on 14MM plug, reach is 3/8 inch; if none appear on 18MM plug, reach is 12MM. Letter "F" in suffix (example) indicates taper seat.

- E ..... 3/8 inch Reach
- F ..... Taper Seat
- H ..... 1/2 inch Reach
- L ..... 7/16 inch Reach

**Electrode Type (S)**—Special electrodes are identified by last letter. Example "S" is "Super Wide Range Electrode."

- C ..... Competition type electrode
- N ..... Racing type (Nickel) electrode
- P ..... Racing type (Platinum) electrode
- S ..... Super wide range electrode
- X ..... Surface gap electrode

# YAMAHA

YAMAHA INTERNATIONAL CORPORATION  
 6600 Orangethorpe Avenue  
 Buena Park, California 90620

## 90 AND 100cc

MODEL	YL-1 YL-1E	HS-1 HS-1B	LS2
Displacement—cc	98	89	98
Bore—MM	38	36.5	38
Stroke—MM	43	43	43
Number of cylinders	2	2	2
Engine Lubrication		Oil Pump	
Spark plug type—			
NGK	B7-HS	B9-HC	B7-HS
Electrode gap—MM	0.6-0.7	0.6-0.7	0.5-0.6
Inch	0.024-0.027	0.024-0.027	0.019-0.024
Ignition—			
Point gap—MM	0.3-0.35	0.3-0.35	0.3-0.4
Inch	0.012-0.014	0.012-0.014	0.012-0.016
Timing—MM BTDC	1.8	1.8	1.8
Electrical system voltage	12	12	12
Battery terminal grounded	Negative	Negative	Negative
Tire Size	2.50 x 17	2.50 x 18	2.50 x 18
Tire pressure—			
Front—kg/cm <sup>2</sup>	1.5	1.5	1.4
Psi	22	22	20
Rear—kg/cm <sup>2</sup>	1.9	1.9	1.9
Psi	28	28	28
Rear chain free play—MM	20	20	20
Inch	¾	¾	¾
Rear chain size	#420	#420	#420
Number of speeds	4	5	5
Weight (approx.)—kg	82	90	95
Pounds	180	199	209

Illustrations courtesy Yamaha International Corporation

### MAINTENANCE

**SPARK PLUGS.** Recommended spark plug electrode gap is 0.5-0.6MM (0.019-0.024 in.) for LS2 models and 0.6-0.7MM (0.024-0.027 in.) for all other models. Recommended spark plug for normal use in 90cc models is NGK type B9-HC or Champion type L-57R-MC. Recommended spark plug for normal use in 100cc models is NGK type B7-HS or Champion type L-81-MC.

**CARBURETORS.** Two Mikuni VM carburetors are used. Idle speed should be set to 1200-1500 RPM for 100cc models; 1100-1200 RPM for 90cc models. Idle speed screw is located on outboard side of each carburetor on LS2 models and on top (2—Fig. Y2-1) of each carburetor on YL-1 and HS-1 models. Make sure that throttle slides (7) both stop at the same position and exhaust pressure is the same for both cylinders. Idle mixture is changed by turning needles (11). Initial setting is 2½ turns open for YL-1 models; 1½ turns open for HS-1 models; 1¾ turns open for LS2 models. Turning the needle counter-clockwise leans the

mixture. Carburetors must be synchronized to open exactly the same amount by turning cable guides (1) on top of carburetors. Float level (H—Fig Y2-2) should be 23MM (0.906 in.) and is adjusted by bending tang (17) on float. Refer to Fig. Y2-1 and the following standard specifications:

#### YL-1 Carburetor

Main jet (9) ..... #55 or 60  
 Pilot jet (14) ..... #17.5  
 Needle jet (13) ..... E-0  
 Valve needle (6) ..... 3D3  
 Clip (5) in third groove from top of needle (6).

#### HS-1 Carburetor

Main jet (9) ..... #70  
 Pilot jet (14) ..... #20  
 Needle jet (13) ..... E-0  
 Valve needle (6) ..... 3G9  
 Clip (5) in fourth groove from top of needle (6).

#### LS2 Carburetor

Main jet (9) ..... #70  
 Pilot jet (14) ..... #15  
 Needle jet (13) ..... 0-0  
 Valve needle (6) ..... 3D12  
 Clip (5) in third groove from top of needle (6).

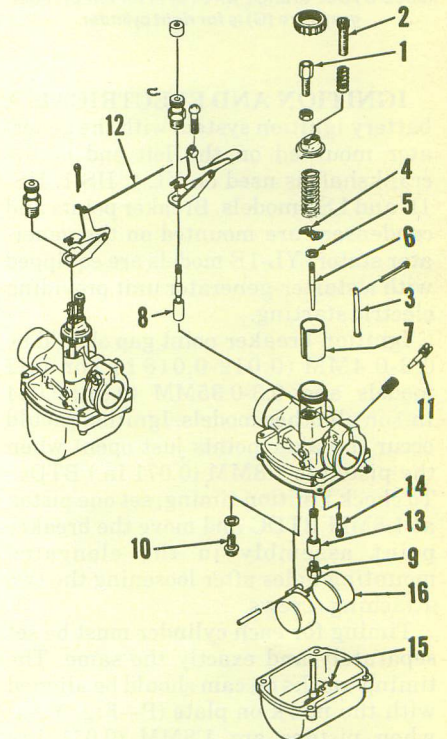

Fig. Y2-1—View of typical VM type Mikuni carburetor. Starting valve (8) is used only on left carburetor on LS2 models. A length of fuel line is used between carburetors so that both cylinders are enriched by left cylinder starting valve.

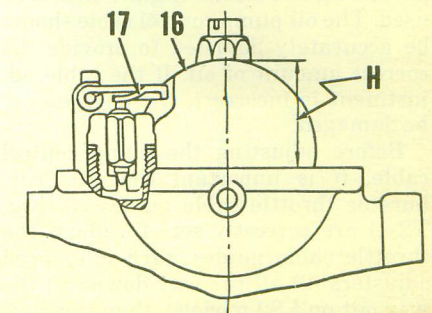

Fig. Y2-2—Float level (H) is adjusted by bending tang (17).

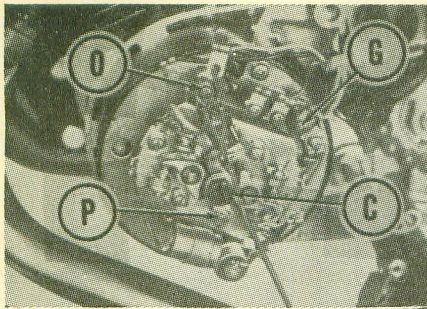

Fig. Y2-4—Timing marks on plate (P) and cam (C) should be aligned when piston is correct distance BTDC. Orange wire (O) is for left cylinder, gray wire (G) is for right cylinder.

**IGNITION AND ELECTRICAL.** A battery ignition system with the generator mounted on the left end of the crankshaft is used on YL-1, HS-1, HS-1B and LS2 models. Breaker points and condensers are mounted on the generator stator. YL-1E models are equipped with a starter-generator unit providing electric starting.

Ignition breaker point gap should be 0.3-0.4MM (0.012-0.016 in.) on LS2 models and 0.3-0.35MM (0.012-0.014 in.) on all other models. Ignition should occur (breaker points just open) when the piston is 1.8MM (0.071 in.) BTDC. To check ignition timing, set one piston at 1.8MM BTDC and move the breaker point assembly in the elongated mounting holes after loosening the two attaching screws.

Timing for each cylinder must be set separately and exactly the same. The timing marks on cam should be aligned with the mark on plate (P—Fig. Y2-4) when pistons are 1.8MM (0.071 in.) BTDC. A static timing light or meter can be used to indicate breaker point opening. If the timing marks on cam and plate (P) are correctly aligned, a power timing light can be used to check ignition timing.

**LUBRICATION.** The engine is lubricated by oil contained in a separate tank. An oil pump forces the oil from tank to each cylinder intake passage. The oil tank should **never** be allowed to run dry. An oil intended for use in air cooled, two stroke engines should be used. The oil pump control cable should be accurately adjusted to provide the correct amount of oil. If the cable adjustment is incorrect, the engine may be damaged.

Before adjusting the pump control cable, it is important that the carburetor throttle cable guides (1—Fig. Y2-1) are correctly set. To adjust the throttle cable guides, turn idle speed adjusters (2) all the way down (all the way out on LS2 models), then synchronize the cable guides (1) so that both throttle slides (7) begin to move at ex-

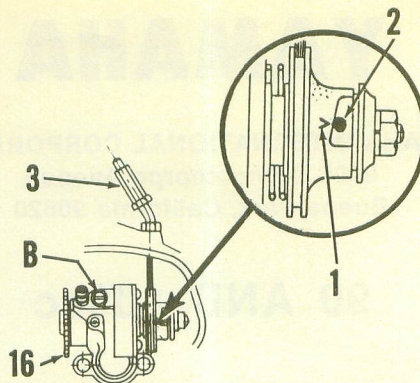

Fig. Y2-5—When carburetor controls are correctly adjusted and engine is at idle speed, "V" mark (1) should be aligned with guide pin (2). Cable adjuster is shown at (3).

actly the same time when the hand grip is turned. The throttle cables should have approximately 1MM free play at idle position after they are synchronized. Adjust idle speed to 1200-1500 RPM on 100cc models and 1100-1200 RPM on 90cc models by turning both idle speed adjusters. Make sure that both throttle slides contact stops at the same time. Turn the throttle hand grip just enough to take up free play from the throttle cables (without changing idle speed) and check the oil pump setting mark and guide pin as shown in Fig. Y2-5. If the "V" mark (1) is not exactly aligned with the guide pin (2), loosen the lock nut and turn the pump cable adjuster (3) as required for alignment.

Check the minimum plunger stroke by turning starter plate (16—Fig. Y2-5) until clearance (A—Fig. Y2-7) between pulley and adjusting plate is at its minimum. Clearance (A) should be 0.25-0.35MM (0.0098-0.0138 inch) for YL-1 and YL-1E models and 0.20-0.25MM (0.0078-0.0098 inch) for HS-1, HS-1B and LS2 models. If clearance is incorrect, add or deduct shims (8).

Fig. Y2-6—Exploded view of the oil injection pump unit.

1. Pump case
2. Cover
3. Pulley spring
4. Adjust pulley
5. Guide pin
6. Adjust plate
7. Snap ring
8. Shims
9. Plunger
10. Plunger return spring
11. Cam guide pin
12. Plunger oil seal
13. Plunger cam oil seal
14. Distributor
15. Oil seal
16. Starter plate
17. Drive pin
18. Check balls
19. Springs
20. Delivery pipes
21. Banjo bolts
22. Injector bolt
23. Worm wheel
24. Worm wheel pin
25. Spring
26. Worm shaft
27. Bushing
28. Oil seal
29. Pin
30. Drive gear
31. Worm wheel plate
32. Spring seat

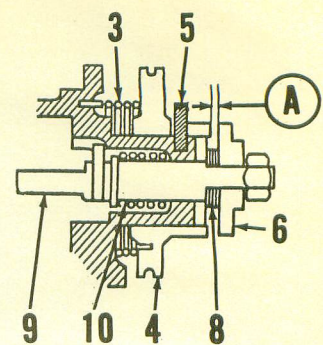
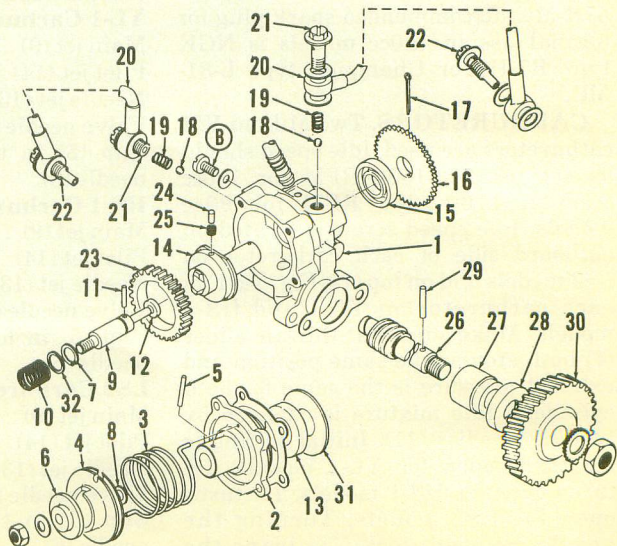

Fig. Y2-7—Clearance (A) is adjusted by varying shims (8). Refer to text for proper clearance.

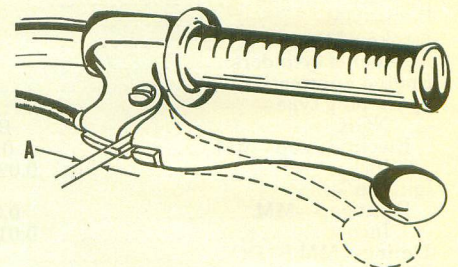

Fig. Y2-9—The clutch hand lever should have 2-3MM free play at (A).

If oil lines are drained or pump is removed, it is important that all lines be filled before starting engine. Remove bleeder screw (B—Fig. Y2-5) and pull the pump control cable up out of cable guide (3). Turn starter plate (16) until oil without air bubbles flows from the bleeder screw hole, then reinstall bleeder screw (B) and start engine. Run engine at idle speed until oil delivery lines (20—Fig. Y2-6) are free of air bubbles.

The gear box contains 750cc of SAE 30 motor oil and should be drained and refilled every 2000 miles.

**CLUTCH CONTROLS.** The clutch hand lever should have 2-3MM (1/8 in.)

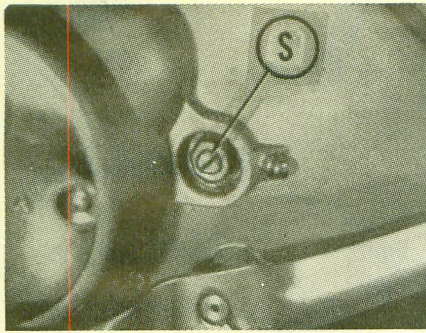

Fig. Y2-10—The clutch adjusting screw (S) is located under rubber plug in engine left side cover.

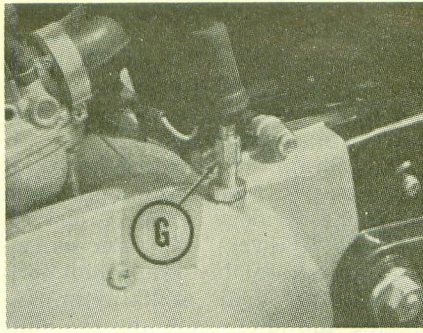

Fig. Y2-11—Clutch hand lever (cable) free play is adjusted by turning cable guide (G).

free play at (A—Fig. Y2-9). To adjust, remove the rubber plug from engine left side cover and loosen lock nut. Turn the adjusting screw (S—Fig. Y2-10) in until slight resistance is felt, then back screw out ¼ turn and tighten lock nut. Turn the cable guide (G—Fig. Y2-11) until the hand lever free play (A—Fig. Y2-9) is correct.

**SUSPENSION.** The YL-1 front suspension unit contains 130cc of SAE 30 motor oil each. The units used on HS-1 and LS2 models contain 150cc of oil each. Oil in the front forks should be drained and filled with new oil every 4000 miles. Refer to Fig. Y2-12.

**REPAIRS**

**PISTONS, RINGS AND CYLINDERS.** Each piston can be removed after removing exhaust pipe, carburetor, cylinder head and cylinder. A shop towel should be placed around connecting rods as cylinders are lifted to prevent carbon particles or other foreign material from falling into open crankcase. Refer to the following standard repair specifications.

- Piston skirt to cylinder clearance . . . . . 0.035-0.040MM (0.0013-0.0016 in.)
- Maximum cylinder taper or out of round . . . . . 0.05MM (0.002 in.)
- Piston ring end gap . . . . . 0.10-0.30MM (0.004-0.012 in.)
- Ring clearance in groove—  
Top . . . . . 0.03-0.07MM (0.0012-0.0027 in.)

Piston skirt clearance in cylinder bore should be measured by first measuring piston diameter at right angles to piston pin and cylinder bore diameter, then subtracting. The piston should be measured 10MM (0.4 inch) above bottom edge of skirt. The dark piston ring should be installed in lower groove and chrome plated ring should be in top groove. Make sure that rings correctly engage pins in the ring grooves. A Keystone type piston ring is used in HS-1 and LS2 models. See Fig. Y2-15A. Keystone rings cannot be in-

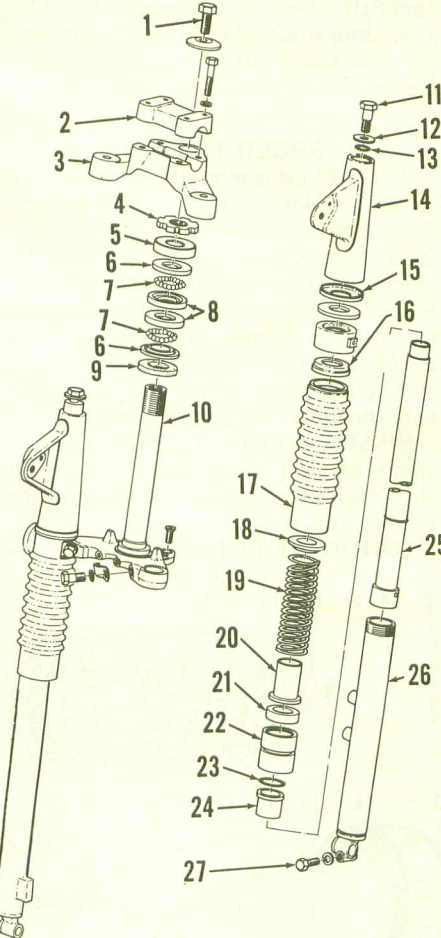

Fig. Y2-12—Exploded view of front fork assembly used on HS-1. Forks used on other models are similar.

- |                             |                     |
|-----------------------------|---------------------|
| 1. Stem bolt                | 14. Bracket         |
| 2. Handlebar clamp          | 15. Holder          |
| 3. Top crown                | 16. Guide           |
| 4. Stem nut                 | 17. Boot            |
| 5. Dust cover               | 18. Spring seat     |
| 6. Bearing cone             | 19. Spring          |
| 7. Bearing balls (38 total) | 20. Spring guide    |
| 8. Bearing cups             | 21. Oil seal        |
| 9. Dust seal                | 22. Outer tube nut  |
| 10. Steering stem           | 23. "O" ring        |
| 11. Fork top bolt           | 24. Metal slide     |
| 12. Washer                  | 25. Inner fork tube |
| 13. "O" ring                | 26. Outer fork tube |
|                             | 27. Axle pinch bolt |

terchanged with the standard type ring. The letter "K" stamped on piston indicates a Keystone type and the ring will be marked "1N" or "1T" for a top ring or "2N" or "2T" for a lower ring. Replacement pistons may be the Keystone type. Marks on all rings are on

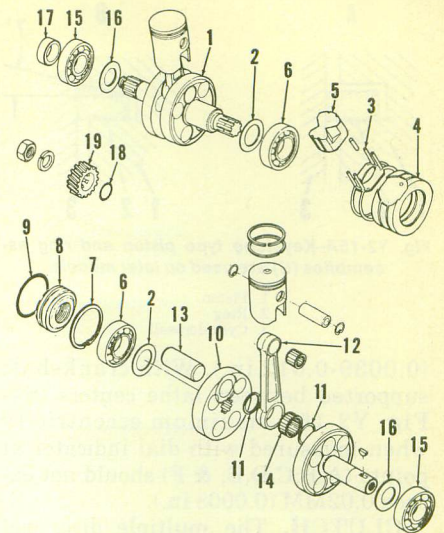

Fig. Y2-14—Exploded view of the crankshaft assembly.

- |                         |                     |
|-------------------------|---------------------|
| 1. Crankshaft right end | 11. Thrust washers  |
| 2. Shims                | 12. Connecting rod  |
| 3. Gasket               | 13. Crankpin        |
| 4. Center housing       | 14. Bearing         |
| 5. Filler               | 15. Main bearings   |
| 6. Center main bearings | 16. Shims           |
| 7. Snap ring            | 17. Oil seal collar |
| 8. Seal                 | 18. "O" ring        |
| 9. "O" ring             | 19. Crankshaft gear |
| 10. Counter weight      |                     |

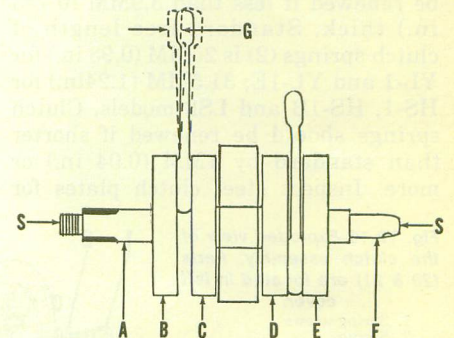

Fig. Y2-15—Refer to text for checking crankshaft for correct assembly or wear.

the top side of ring. Pistons should be installed on connecting rods with arrow pointing toward front. Cylinder head stud nuts should be torqued to 103 kg-cm (90 inch-pounds).

**CONNECTING RODS AND CRANKSHAFT.** The crankcase halves must be separated to remove the crankshaft. Connecting rods, crankpins, rod bearings and the center main bearings are removed by pressing the crankshaft apart. The crankshaft should be disassembled ONLY if required tools are available to correctly check and align the reassembled crankshaft. If side shake (G—Fig. Y2-15) at piston pin end of connecting rod end exceeds 2MM (0.08 in.), the connecting rod, crankpin and lower bearing should be renewed. Shake (G) should be 0.8-1.0MM (0.032-0.039 in.). Side clearance of connecting rod between the crankshaft counter weights can be measured with a feeler gage. Side clearance should be 0.1-0.3MM

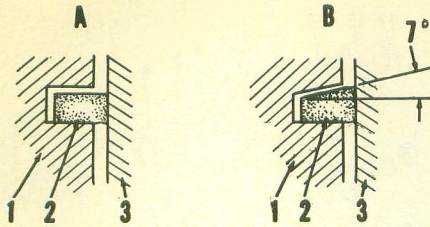

Fig. Y2-15A—Keystone type piston and ring assemblies (B) are used on later models.

1. Piston
2. Ring
3. Cylinder wall

(0.0039-0.012 in.). With crankshaft supported between lathe centers (S—Fig. Y2-15), maximum eccentricity when measured with dial indicator at points (A,B,C,D,E, & F) should not exceed 0.02MM (0.0008 in.).

**CLUTCH.** The multiple disc, wet type clutch is located on the right end of the transmission input shaft. To remove the clutch it is necessary to first remove the engine right side cover.

Clutch friction discs (8—Fig. Y2-16) are 4MM (0.158 inch) thick and should be renewed if less than 3.9MM (0.153 in.) thick. Standard free length of clutch springs (2) is 25MM (0.98 in.) for YL-1 and YL-1E; 31.5MM (1.24in.) for HS-1, HS-1B and LS2 models. Clutch springs should be renewed if shorter than standard by 1MM (0.04 in.) or more. Inspect steel clutch plates for

warpage or discoloration from overheating.

**CRANKCASE AND GEAR BOX.** The crankshaft and transmission parts can be removed after the crankcase halves are separated.

To separate the crankcase halves, it is necessary to remove the engine from the frame. Remove cylinders, pistons, engine side covers, generator assembly, clutch assembly, crankshaft (primary drive) gear, kickstarter (including the idler gear) and the shift shaft and linkage. Remove the screws that attach the halves together and carefully separate the halves. The gears and shafts should stay in place in the crankcase left half. Refer to Figs. Y2-18, Y2-19 and Y2-20.

**SPEED TUNING**

A "GYT" kit is available for the YL-1 (100 Twin Jet). A YL-1 "GYT" kit will fit on HS-1 and LS2 models. Many features in the YL-1 "GYT" kit may be machined into standard parts. The following specifications may improve performance in Yamaha 100cc twins. Any modification of standard parts or installation of performance parts will void the manufacturers warranty.

**SPARK PLUG.** An NGK type B-10EN or B-11EN should be used and shimmed with extra plug washers for correct fit.

**CARBURETOR.** Standard car-

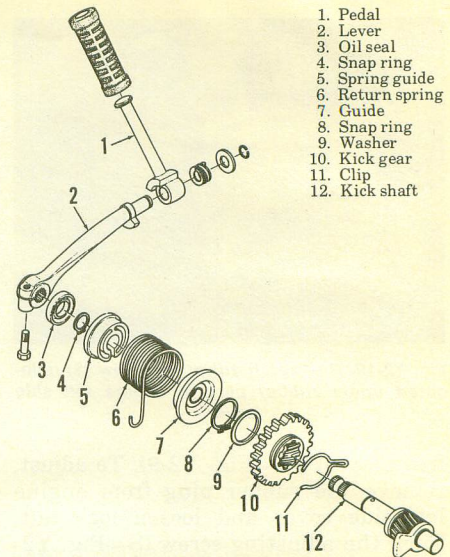

Fig. Y2-20—Exploded view of kickstarter typical of HS-1, HS-1B and LS2 models.

buretor should be used and intake port diameter should be carefully matched to carburetor bore diameter.

**IGNITION.** Armature may be turned down to bare shaft and total loss ignition used or a specially constructed magneto is available. All unused wiring should be removed.

**LUBRICATION.** Oil metering pump should be removed and hole plugged to prevent loss of transmission lubricant. Use a 15:1 or 16:1 fuel to oil mixture in fuel tank. Only oils intended for use in two stroke air cooled engines should be used. Make certain that oil feed holes in cylinders are also plugged.

**CYLINDER, PISTON AND HEAD.** Cylinder head should be milled 1.5MM (0.060 in.). Make certain that 20 degree taper is remachined in edge of combustion chamber.

Piston skirt should be shortened by 5MM (0.196 inch) and only top piston ring should be used. Height of piston after modification should be 46.5MM (1.83 inches) when measured along the side.

Fig. Y2-16—Exploded view of the clutch assembly. Parts (20 & 21) are located in left cover.

1. Spring screws
2. Springs
3. Pressure plate
4. Release plunger
5. Nut
6. Lock plate
7. Driven plate (5 used)
8. Friction discs (4 used)
9. Separator rings (4 used)
10. Clutch hub
11. Thrust plate
12. Thrust bearing
13. Friction ring
14. Clutch drum
15. Bushing
16. Kick starter gear
17. Thrust plate
18. Balls
19. Release rod
20. Release screw
21. Adjusting screw

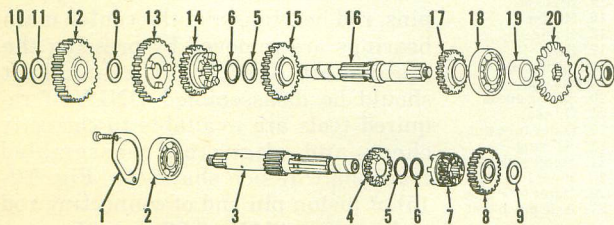
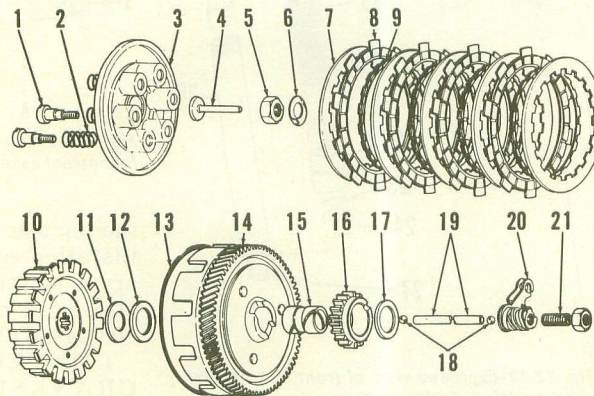

Fig. Y2-18—Exploded view of four speed transmission gears and shafts used in the YL-1.

- |                               |                             |                        |
|-------------------------------|-----------------------------|------------------------|
| 1. Bearing retainer           | 7. Sliding gear (2nd)       | 14. Sliding gear (3rd) |
| 2. Bearing                    | 8. Fourth gear              | 15. Second gear        |
| 3. Input shaft and first gear | 9. Shims                    | 16. Output shaft       |
| 4. Third gear                 | 10. Snap ring               | 17. Fourth gear        |
| 5. Thrust washers             | 11. Thrust washer           | 18. Bearing            |
| 6. Snap rings                 | 12. Kick starter idler gear | 19. Seal collar        |
|                               | 13. First gear              | 20. Output sprocket    |

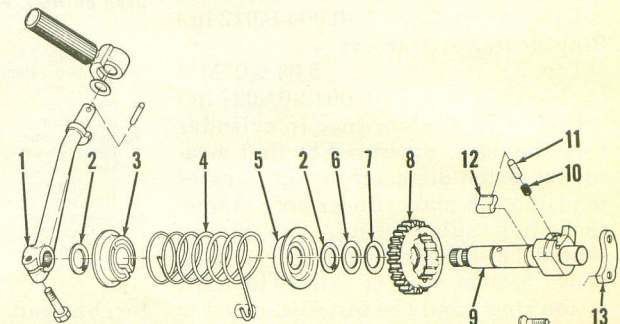

Fig. Y2-19—Exploded view of kickstarter assembly used on YL-1 models.

- |                  |                      |                |
|------------------|----------------------|----------------|
| 1. Pedal         | 5. Spring guide      | 10. Spring     |
| 2. Snap rings    | 6. Shim              | 11. Plunger    |
| 3. Spring cover  | 7. Wave washer       | 12. Ratchet    |
| 4. Return spring | 8. Kick starter gear | 13. Stop plate |
|                  | 9. Starter shaft     |                |

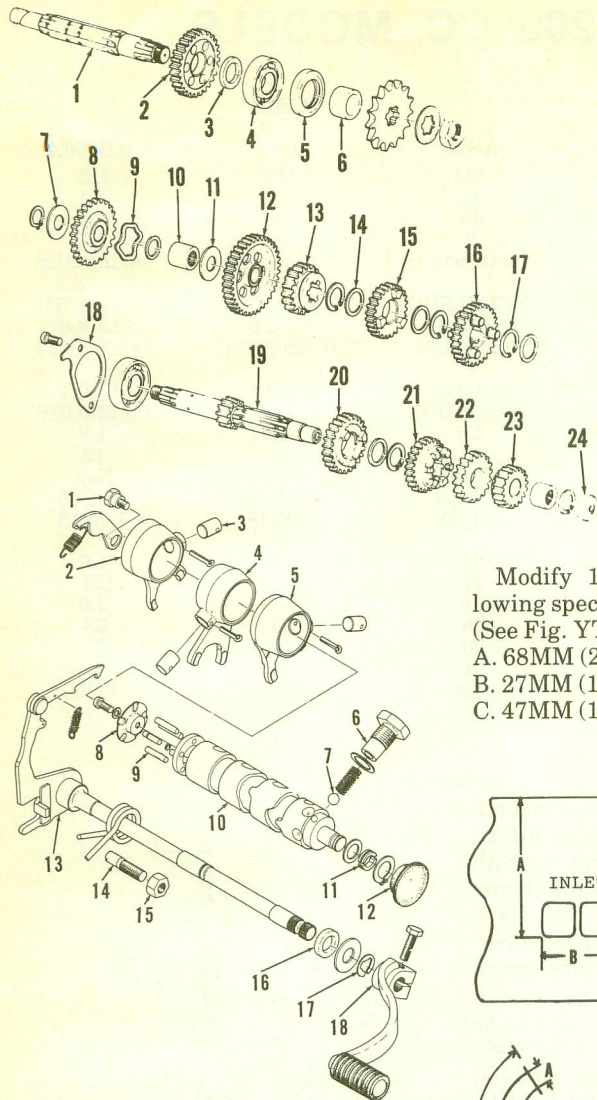

Fig. Y2-21-Exploded view of five speed transmission.

1. Drive axle
2. Second gear wheel
3. Spacer
4. Ball bearing
5. Oil seal
6. Distance collar
7. Drive axle shim
8. Kick idle gear
9. Wave washer
10. Needle bearing
11. Drive axle shim
12. First gear wheel
13. Fifth gear wheel
14. Gear hold washer
15. Fourth gear wheel
16. Third gear wheel
17. Snap ring
18. Bearing cover plate
19. Main axle
20. Fifth pinion gear
21. Fourth pinion gear
22. Third pinion gear
23. Second pinion gear
24. Push rod seal

- E. 34MM (1.338 in.)
- H. 24MM (0.945 in.)
- I. 25MM (0.984 in.)

Dimensions not shown are left standard.

**EXPANSION CHAMBER.** A high RPM expansion chamber may be constructed using the following specifications:

(See YT2-2)

- A. 31.5MM (1.239 in.)
- B. 226MM (8.987 in.)
- C. 40MM (1.574 in.)
- D. 50MM (1.968 in.)
- E. 66MM (2.598 in.)
- F. 87MM (3.425 in.)
- G. 62MM (2.440 in.)
- H. 20MM (0.787 in.)
- I. 60MM (2.362 in.)
- J. 95MM (3.740 in.)
- K. 80MM (3.149 in.)
- L. 40MM (1.574 in.)
- M. 70MM (2.755 in.)
- N. 90MM (3.149 in.)
- O. 150MM (5.905 in.)

Modify 100cc cylinders to the following specifications:

(See Fig. YT2-1)

- A. 68MM (2.677 in.)
- B. 27MM (1.063 in.)
- C. 47MM (1.850 in.)

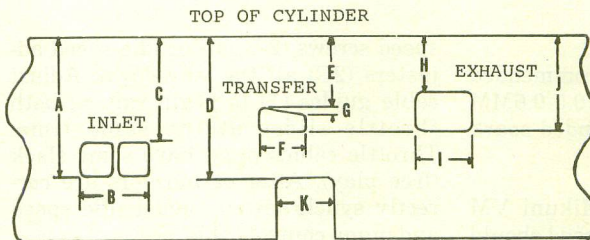

Fig. YT2-1-Diagram of cylinder porting used on YL-1 "GYT" kit. Refer to text for dimensions.

Fig. Y2-22-View of shifter components used on five speed models. Shifter on four speed units is similar.

1. Stopper bolt
2. Third shift fork
3. Cam follower pin
4. Second shift fork
5. First shift fork
6. Neutral spring holding bolt
7. Neutral detent ball
8. Side plate
9. Locating pin
10. Shifting cam
11. Shifting cam holders
12. Blind plug
13. Change shaft assembly
14. Eccentric screw
15. Lock nut
16. Oil seal
17. Snap ring
18. Change lever

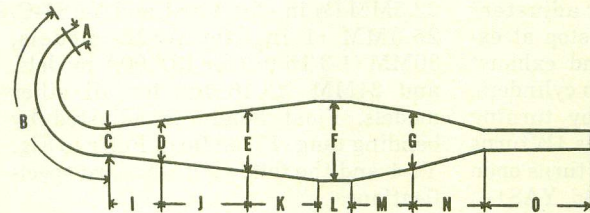

Fig. YT2-2-An expansion chamber constructed to this set of specifications will produce a high RPM (peaky) performing engine.

# YAMAHA 125, 180 AND 200 CC MODELS

MODEL	YCS1 YCS1-C	YAS1 YAS1-C	AS2C	CS3B CS3C CS5	RD200A
Displacement—cc	180	124	124	195	195
Bore—MM	50	43	43	52	52
Stroke—MM	46	43	43	46	46
Number of cylinders	2	2	2	2	2
Engine lubrication	Oil injection	Oil injection	Oil injection	Oil injection	Oil injection
Spark plug—					
Type	NKG B-8HS	NKG B-8HS	NKG B-8HS	NKG B-8HS	NKG B-8HS
Electrode gap—MM	0.5-0.6	0.5-0.6	0.5-0.6	0.5-0.6	0.5-0.6
Inch	0.020-0.024	0.020-0.024	0.020-0.024	0.020-0.024	0.020-0.024
Ignition—					
Point gap—MM	0.3-0.4	0.3-0.4	0.3-0.4	0.3-0.4	0.3-0.4
Inch	0.012-0.016	0.012-0.016	0.012-0.016	0.012-0.016	0.012-0.016
Timing—MM BTDC	1.8	1.8	1.8	1.8	1.8
Electrical system voltage	12	12	12	12	12
Battery terminal grounded	Neg	Neg	Neg	Neg	Neg
Tire size—Front	2.50-18	2.50-18	2.75-18	2.75-18	2.75-18
Rear	2.75-18	2.75-18	3.00-18	3.00-18	3.00-18
Tire pressure—					
Front—kg/cm <sup>2</sup>	1.5	1.5	1.5	1.6	1.6
Psi	22	22	22	23	23
Rear—kg/cm <sup>2</sup>	1.8	1.8	1.8	2.0	2.0
Psi	26	26	26	28	28
Rear chain free play—MM	13-16	13-16	20	20	20
Inch	½-¾	½-¾	¾	¾	¾
Rear chain size	#428	#428	#428	#428	#428
Number of speeds	5	5	5	5	5

Illustrations courtesy of Yamaha International Corporation

## MAINTENANCE

**SPARK PLUGS.** Recommended spark plug electrode gap is 0.5-0.6MM (0.020-0.024 in.). Recommended spark plug is NGK type B-8HS.

**CARBURETOR.** Two Mikuni VM carburetors are used. Idle speed should be set to 1,100-1,300 rpm by turning screws (2A—Fig. Y4-1) or adjusters (2C). Make sure that both stop at exactly the same position and exhaust pressure is the same for both cylinders. Idle mixture is changed by turning needles (11). Initial setting is 1¼ turns open on model RD200A, 1¾ turns open on models AS2C, YAS1 and YAS1-C and 2 turns open on all other models. Turning the needle counter-clockwise leans the mixture. Carburetors must be synchronized to open exactly the same amount by turning cable guides (1) on top of each carburetor. To synchronize, begin by turning both idle

speed screws (2A) out or idle speed adjusters (2C) all the way down. Adjust cable guides (1) to begin raising both throttle slides at the same time. Throttle cables must have some slack (free play). After carburetors are correctly synchronized, adjust idle speed and pump control cable.

Float level (H—Fig. Y4-3) should be 22.5MM (¾ in.) for YAS1 and YAS1-C, 25.3MM (1 in.) for AS2C models, 30MM (1-3/16 in.) for RD200A models, and 21MM (13/16 in.) for all other models. Float height is adjusted by bending tang (17) on float. Refer to Fig. Y4-1 and the following standard specifications:

### YAS1, YAS1-C & AS2C

- Main jet (9) ..... #95
- Pilot jet (14) ..... #17.5
- Needle jet (13) ..... 0-0
- Valve needle (6) ..... 4D9
- Clip (5) in fourth groove from top of needle (6).

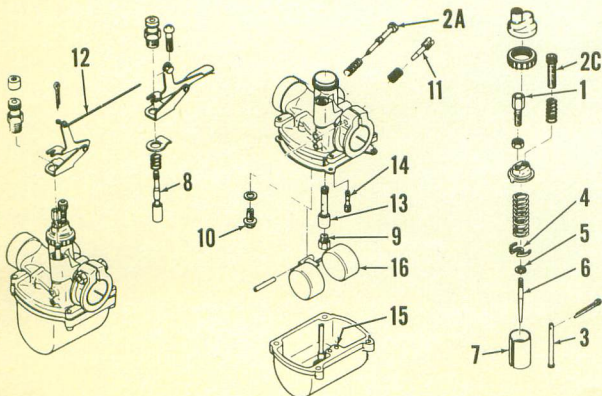

Fig. Y4-1—Exploded view of Mikuni VM carburetor used on early models. Starting valves for both carburetors are connected with rod (12).

1. Throttle cable guide
- 2A. Idle speed screw
- 2C. Idle speed adjuster
3. Idle speed rod
4. Retainer
5. Clip
6. Valve needle
7. Throttle slide
8. Starting valve
9. Main jet
10. Fuel inlet valve
11. Idle mixture needle
12. Link rod
13. Needle jet
14. Pilot jet
15. Starting jet
16. Float

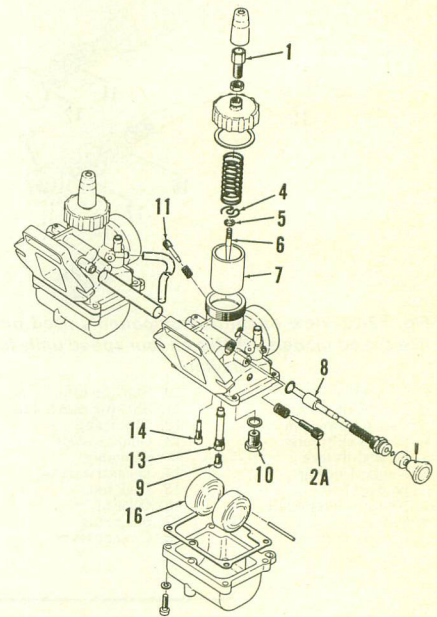

Fig. Y4-2—Exploded view of Mikuni carburetors used on model RD200A. Refer to Fig. Y4-1 for parts identification.

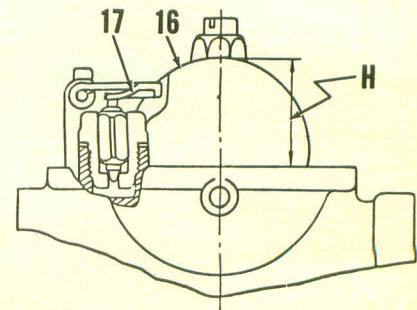

Fig. Y4-3—Float level (H) is adjusted by bending tang (17).

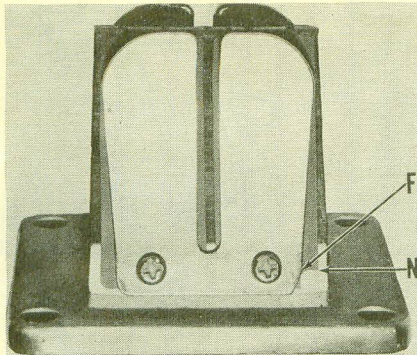

Fig. Y4-4—Notches in reed valve petal (F) and reed petal stop (N) must be adjacent on model RD200A.

**YCS1**

- Main jet (9) .....#65
- Pilot jet (14) .....#20
- Needle jet (13) ..... 0-0
- Valve needle (6) .....4D2
- Clip (5) in third groove from top of needle (6).

**YCS1-C, CS3B, CS3C & CS5**

- Main Jet (9) .....#65
- Pilot jet (14) .....#30
- Needle jet (13) ..... N-6\*
- Valve needle (6) ..... 4D10
- \*Use 0-6 needle jet on model CS5.
- Clip (5) in third groove from top of needle (6).

**RD200A**

- Main jet (9) .....#94
- Pilot jet (14) .....#42
- Needle jet (13) ..... N-80
- Valve needle (6) ..... 4F51
- Clip (5) in third groove from top of needle (6).

Model RD200A is equipped with reed valve induction. Reed valve petals must be installed so that notch in petal (F—Fig. Y4-4) is next to notch (N) in reed petal stop.

**IGNITION AND ELECTRICAL.**

The alternator on YAS1, YAS1-C and AS2C models is located at left end of crankshaft. On all other models, the DC generator-starter unit is located at

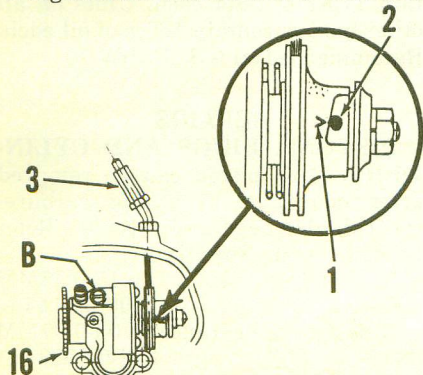
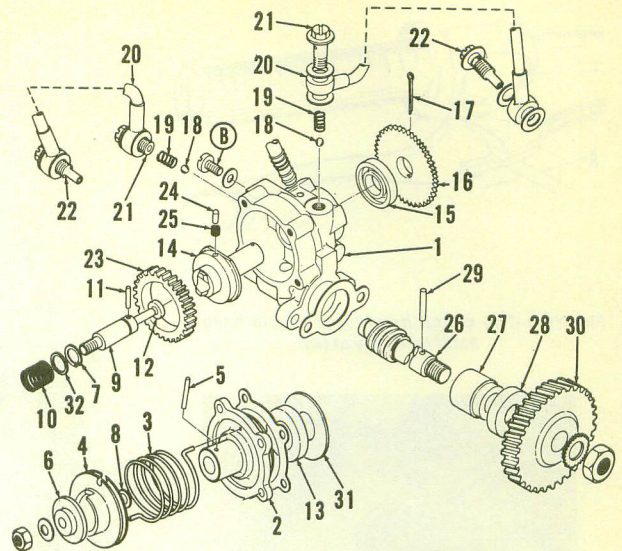

Fig. Y4-5—When carburetor controls are correctly adjusted and engine is at idle speed, mark (1) should be aligned with guide pin (2). Cable adjuster is shown at (3).

Fig. Y4-6—Exploded view of the oil injection pump unit.

1. Pump case
2. Cover
3. Pulley spring
4. Adjust pulley
5. Guide pin
6. Adjust plate
7. Snap ring
8. Shims
9. Plunger
10. Plunger return spring
11. Cam guide pin
12. Plunger oil seal
13. Plunger cam oil seal
14. Distributor
15. Oil seal
16. Starter plate
17. Drive pin
18. Check balls
19. Springs
20. Delivery pipes
21. Banjo bolts
22. Injector bolt
23. Worm wheel
24. Worm wheel pin
25. Spring
26. Worm shaft
27. Bushing
28. Oil seal
29. Pin
30. Drive gear
31. Worm wheel plate
32. Spring seat



the left end of the crankshaft. On all models, the ignition breaker points and condensers are mounted on the stator plate and the ignition cam is attached to the end of the generator armature (rotor on YAS1, YAS1-C and AS2C models).

Ignition breaker point gap at widest opening should be within limits shown in condensed data table. Ignition timing should be set as follows: Turn the crankshaft until the left piston is 1.8MM (0.070 in.) before top dead center. Pull the advance weights out to full advance position and block in this position. If the breaker points are not just open, loosen the mounting screws and move the front set of breaker points in the elongated holes until points just begin to open. Timing for the right cylinder is set in a similar way with dial indicator in right spark plug hole and moving the rear set of breaker points.

**LUBRICATION.** The engine is lubricated by oil contained in a separate tank. A pump and metering unit pumps oil from the tank to each cylinder inlet passage. The oil tank should never be allowed to run dry. SAE 30 two-stroke oil should be used. The oil pump control cable should be accurately adjusted to provide the correct amount of oil. If the cable adjustment is incorrect, the engine may be damaged.

Before adjusting the pump control cable, it is important that the throttle cable guides (1—Fig. Y4-1) are correctly set. To adjust the throttle cable guides, turn the idle speed screws (2A) out or idle speed adjuster (2C) all the way down, then synchronize cable guides (1) so that both throttle slides (7) begin to move at exactly the same time when the hand grip is turned. The

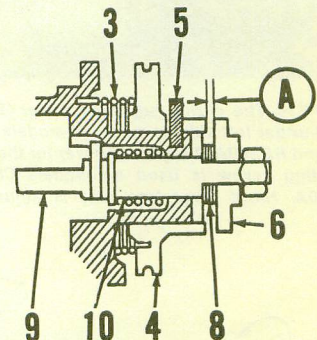

Fig. Y4-7—Clearance (A) is adjusted by varying shims (8).

throttle cables should have approximately 1/16-inch free play after they are synchronized. Adjust the idle speed to 1,100-1,300 rpm by turning both idle screws (2A) or adjusters (2C). Make certain that both throttle slides stop at exactly the same time. Turn the throttle hand grip just enough to take up free play from the throttle cables (without changing idle speed) and check the oil pump setting mark and guide pin as shown in Fig. Y4-5. If the mark (1) is not exactly aligned with guide pin (2), loosen the lock nut and turn the pump cable adjuster (3) as required to align.

Check the minimum plunger stroke by turning starter plate (16) until clearance (A—Fig. Y4-7) between pulley and adjusting plate is at its minimum. Clearance (A) should be 0.20-0.25MM (0.008-0.010 inch). If clearance is incorrect, add or deduct shims (8).

If oil lines are drained or pump is removed, it is important that all lines be filled before starting engine. Remove bleeder screw (B—Fig. Y4-5) and pull the pump control cable up out of cable guide (3). Turn starter plate (16) until oil without air bubbles flows from the bleeder screw hole, then reinstall bleeder screw (B) and start engine. Run

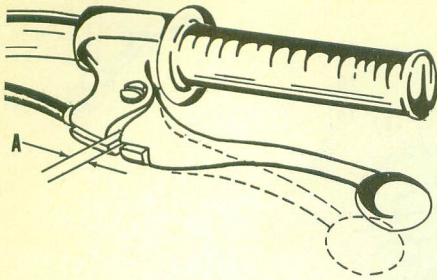

Fig. Y4-9—The clutch hand lever should have 2-3MM free play at (A).

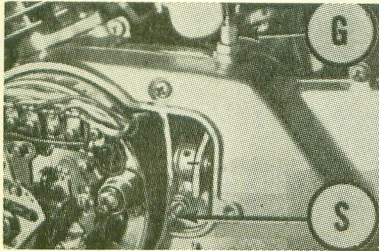

Fig. Y4-10—The clutch adjusting screw (S) is located under left side cover on all models except CS5 and RD200A. A separate cover for the clutch adjusting screw is used on models CS5 and RD200A. Hand lever free play is adjusted at cable guide (G).

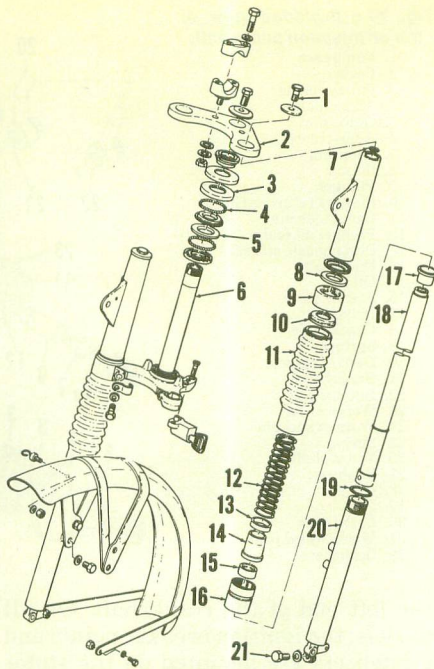

Fig. Y4-13—Exploded view of front suspension used on CS3 models.

- |                           |                       |
|---------------------------|-----------------------|
| 1. Fork top bolt          | 11. Boot              |
| 2. Handle crown           | 12. Fork spring       |
| 3. Ball race              | 13. Spacer            |
| 4. Ball bearings          | 14. Lower spring seat |
| 5. Ball race              | 15. Oil seat          |
| 6. Steering stem assembly | 16. Outer nut         |
| 7. "O" ring               | 17. Metal slide       |
| 8. Packing                | 18. Inner tube        |
| 9. Outer cover            | 19. "O" ring          |
| 10. Spring upper seat     | 20. Outer tube        |
|                           | 21. Axle pinch bolt   |

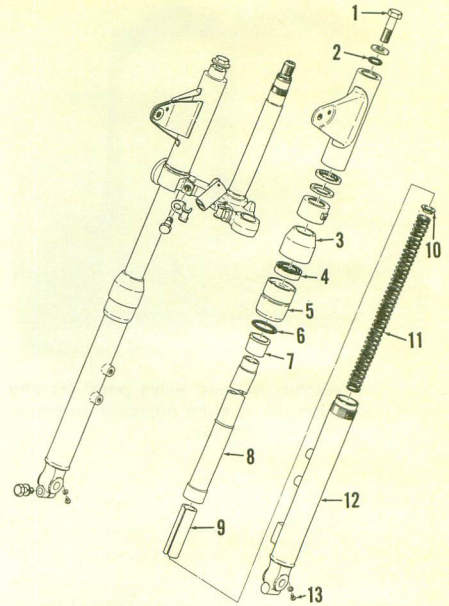

Fig. Y4-13A—Exploded view of front suspension used on models CS5 and RD200A.

- |              |                     |
|--------------|---------------------|
| 1. Fill plug | 8. Inner tube       |
| 2. "O" ring  | 9. Spacer           |
| 3. Dust boot | 10. Spring seat     |
| 4. Oil seal  | 11. Spring          |
| 5. Tube nut  | 12. Outer fork tube |
| 6. "O" ring  | 13. Drain screw     |
| 7. Guide     |                     |

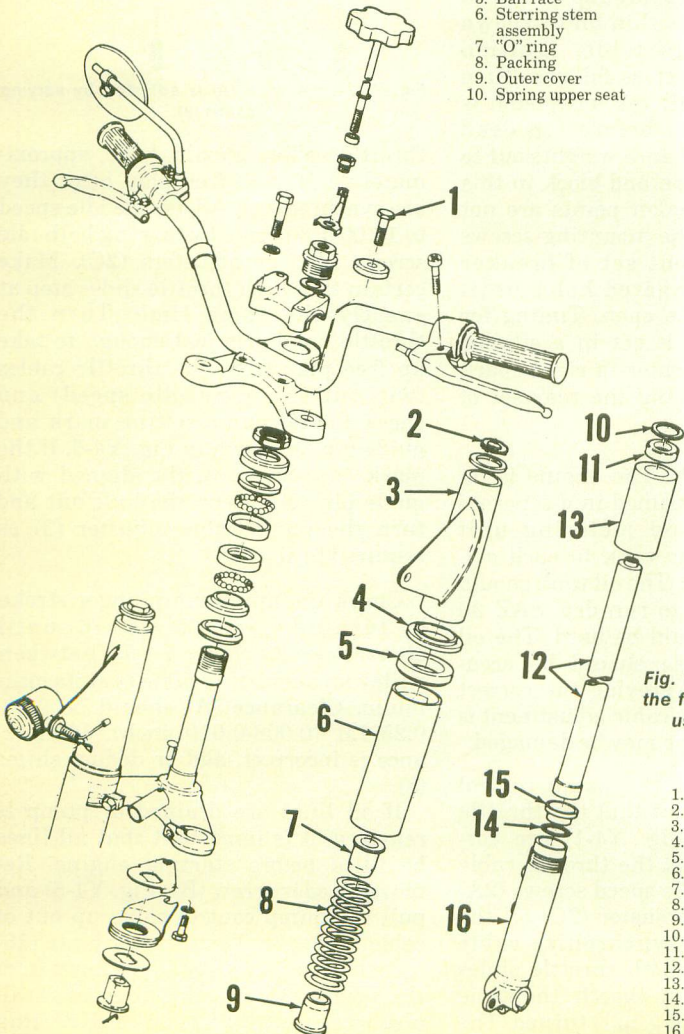

Fig. Y4-12—Exploded view of the front suspension system used on some models.

- |                 |
|-----------------|
| 1. Filler screw |
| 2. Seal         |
| 3. Cover        |
| 4. Guide        |
| 5. Gasket       |
| 6. Cover        |
| 7. Spring seat  |
| 8. Spring       |
| 9. Spring seat  |
| 10. Washer      |
| 11. Oil seal    |
| 12. Inner tube  |
| 13. Tube nut    |
| 14. "O" ring    |
| 15. Bushing     |
| 16. Lower tube  |

engine at idle speed until oil delivery lines (20—Fig. Y4-6) are free of air bubbles.

The gear box contains 850cc (28.7 fl. oz.) of SAE 30 or 10W/30 motor oil and should be drained and refilled every 2000 miles.

**CLUTCH CONTROLS.** The clutch hand lever should have 1/16-1/8 inch free play at (A—Fig. Y4-9). To adjust, remove the engine left side cover or clutch screw cover and loosen lock nut. Turn the adjusting screw (S—Fig. Y4-10) in until slight resistance is felt, then back screw out 1/4 turn and tighten lock nut. Turn the cable guides at ends of cable until the hand lever free play (A—Fig. Y4-9) is correct.

**SUSPENSION.** Front suspension units on CS3C and CS3B models contain 175cc of fluid each. Units on all other models contain 160cc of oil each. Recommended oil is SAE 10W/30.

**REPAIRS**

**PISTONS, RINGS AND CYLINDERS.** Each piston can be removed after removing exhaust pipe, carburetor, cylinder head and cylinder. Refer to the following specifications:

- Ring end gap ..... 0.15-0.35MM (0.006-0.014 in.)
- Ring groove clearance 0.03-0.07MM (0.0012-0.0028 in.)

- Standard cylinder bore diameter—
- 124cc ..... 43MM (1.69 inches)
  - 180cc ..... 50MM (1.97 inches)
  - 195cc ..... 52MM (2.047 inches)

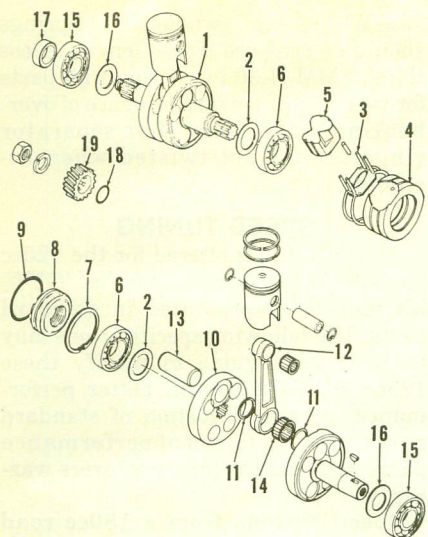

Fig. Y4-14—Exploded view of the crankshaft assembly.

- |                         |                     |
|-------------------------|---------------------|
| 1. Crankshaft right end | 11. Thrust washers  |
| 2. Shims                | 12. Connecting rod  |
| 3. Gasket               | 13. Crankpin        |
| 4. Center housing       | 14. Bearing         |
| 5. Filler               | 15. Main bearings   |
| 6. Center main bearings | 16. Shims           |
| 7. Snap ring            | 17. Oil seal collar |
| 8. Seal                 | 18. "O" ring        |
| 9. "O" ring             | 19. Crankshaft gear |
| 10. Counter weight      |                     |

Maximum cylinder bore taper or out of round . . . . . 0.05MM (0.002 in.)

Piston skirt to cylinder clearance—  
 YAS1 & YCS1 . . . . . 0.040-0.045MM (0.0016-0.0018 in.)  
 AS2C . . . . . 0.050-0.055MM (0.0019-0.0022 in.)  
 CS3C & CS3B . . . . . 0.030-0.035MM (0.0012-0.0014 in.)  
 CS5 & RD200A . . . . . 0.040-0.045MM (0.0016-0.0018 in.)

Piston skirt clearance in cylinder bore should be measured by first measuring piston diameter at right angles to piston pin and cylinder bore diameter, then subtracting. The piston should be measured 10MM (0.4 inch) above bottom edge of skirt. On piston rings sets with a chrome ring and a black ring, install the chrome ring in top groove and black ring in second groove. Some ring sets will have two chrome rings. These can be installed in

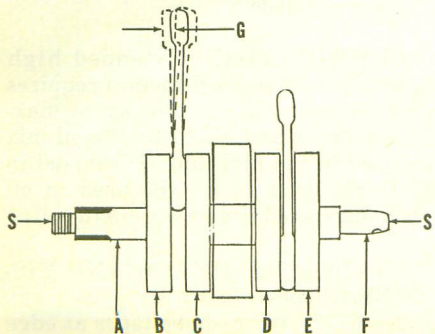

Fig. Y4-15—Refer to text for checking crankshaft assembly and wear limits.

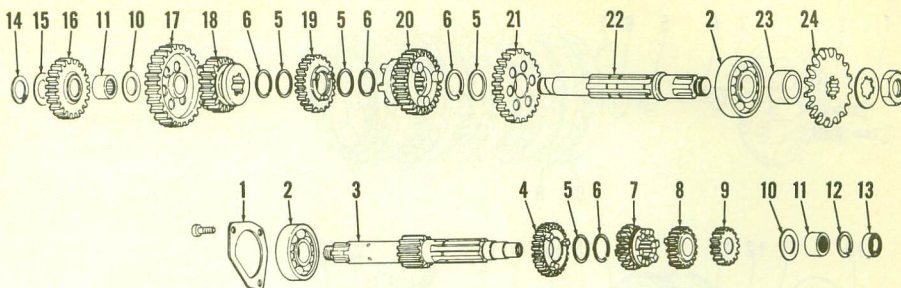
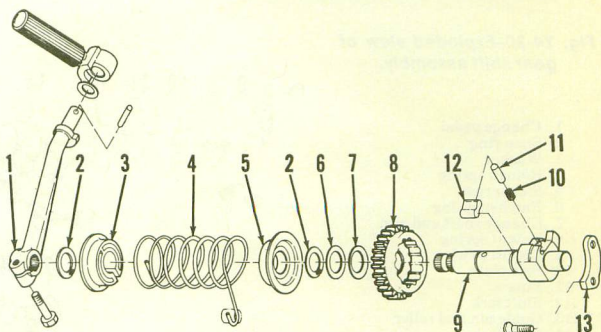

Fig. Y4-16—Exploded view of the transmission gears and shafts.

- |                               |                       |                             |                        |
|-------------------------------|-----------------------|-----------------------------|------------------------|
| 1. Bearing retainer           | 7. Sliding gear (4th) | 13. Push rod oil seal       | 18. Sliding gear (5th) |
| 2. Bearing                    | 8. Third gear         | 14. Snap ring               | 19. Fourth gear        |
| 3. Input shaft and first gear | 9. Second gear        | 15. Thrust washer           | 20. Sliding gear (3rd) |
| 4. Fifth gear                 | 10. Shims             | 16. Kick starter idler gear | 21. Second gear        |
| 5. Thrust washers             | 11. Bearings          | 17. First gear              | 22. Output shaft       |
| 6. Snap rings                 | 12. Snap ring         |                             | 23. Spacer             |
|                               |                       |                             | 24. Output sprocket    |

Fig. Y4-17—Exploded view of early kickstarter. Gear (8) meshes with gear (16—Fig. Y4-16).

- |                  |                      |
|------------------|----------------------|
| 1. Pedal         | 8. Kick starter gear |
| 2. Snap rings    | 9. Starter shaft     |
| 3. Spring cover  | 10. Spring           |
| 4. Return spring | 11. Plunger          |
| 5. Spring guide  | 12. Ratchet          |
| 6. Shim          | 13. Stop plate       |
| 7. Wave washer   |                      |



either groove. On late models, Keystone type pistons and rings are used. Keystone type pistons will be marked with a "K" stamped on top and Keystone rings will be marked "1N" or "1T" for a top ring and "2N" or "2T" for a bottom ring. Keystone rings cannot be used in a standard piston and standard rings cannot be used in a Keystone piston. Keystone pistons are supplied as replacement parts for all models. Marks on all piston rings go toward top. Make sure that rings correctly engage pins in the ring grooves. Pistons should be installed on connecting rods with arrow pointing toward front. Cylinder head stud nuts should be torqued to 180 inch-pounds.

**CONNECTING RODS AND CRANKSHAFT.** The crankcase halves must be separated to remove the crankshaft. Connecting rods, crankpins, rod bearings and the center main bearings are removed by pressing the crankshaft apart. The crankshaft should be disassembled ONLY if required tools are available to correctly check and align the reassembled crankshaft. If side shake (G—Fig. Y4-15) at piston pin end of connecting rod exceeds 2MM (0.08 in.), the connecting rod, crankpin and lower bearing should be renewed. Shake (G) should be 0.8-1.0MM (0.032-0.039 in.). Side clearance of connecting rod between the crankshaft counter weights can be measured with a feeler gage. Side clearance should be 0.1-0.3MM

(0.0039-0.012 in.). With crankshaft supported between lathe centers (S—Fig. Y4-15), maximum eccentricity when measured with dial indicator at points (A, B, C, D, E, & F) should not exceed 0.0008 inch.

Distance from outer surface of crankwheel (B—Fig. Y4-15) to outer surface of crankwheel (E) should be 139.8-140.0MM (5.504-5.512 in.). Distance

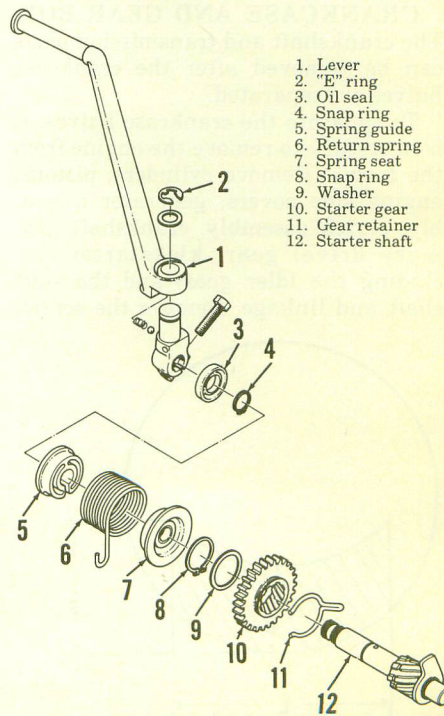

Fig. Y4-18—Exploded view of kick starter assembly used on models CS5 and RD200A.

- |                   |
|-------------------|
| 1. Lever          |
| 2. "E" ring       |
| 3. Oil seal       |
| 4. Snap ring      |
| 5. Spring guide   |
| 6. Return spring  |
| 7. Spring seat    |
| 8. Snap ring      |
| 9. Washer         |
| 10. Starter gear  |
| 11. Gear retainer |
| 12. Starter shaft |

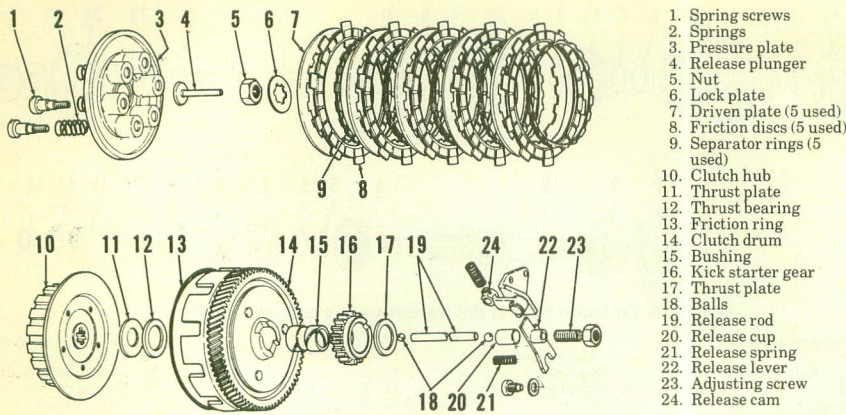
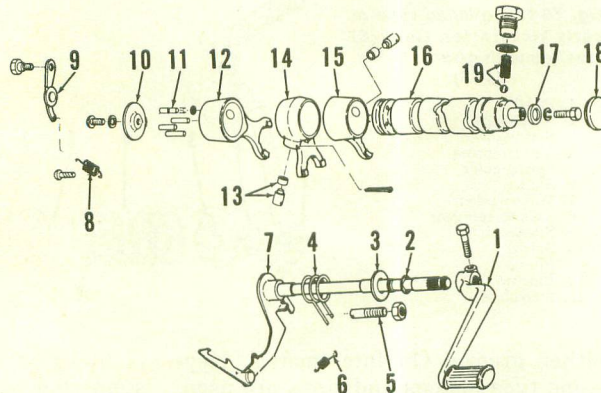

Fig. Y4-19—Exploded view of the clutch assembly. Parts (20 thru 24) are located in left cover.

Fig. Y4-20—Exploded view of gear shift assembly.

1. Change pedal
2. Snap ring
3. Washer
4. Return spring
5. Stop screw
6. Ratchet spring
7. Change shaft and arm
8. Detent spring
9. Detent pawl
10. Side plate
11. Pins
12. Shift fork
13. Guide pin and roller
14. Shift fork
15. Shift fork
16. Shift drum
17. Retainer washer
18. Plug
19. Neutral detent ball and spring



from outer surface of crankwheel (B) to outer surface of crankwheel (C) and distance from outer surface of crankwheel (D) to outer surface of crankwheel (E) should be 46.90-46.95MM (1.846-1.848 in.).

**CRANKCASE AND GEAR BOX.**

The crankshaft and transmission parts can be removed after the crankcase halves are separated.

To separate the crankcase halves, it is necessary to remove the engine from the frame. Remove cylinders, pistons, engine side covers, generator assembly, clutch assembly, crankshaft (primary drive) gear, kickstarter (including the idler gear) and the shift shaft and linkage. Remove the screws

that attach the halves together and carefully separate the halves. The gears and shafts should stay in place in the crankcase left half. Refer to Figs. Y4-16, Y4-17, and Y4-20.

When reassembling, make sure that transmission parts are all in neutral position.

**CLUTCH.** The multiple disc, wet type clutch is located on the right end of the transmission input shaft. To remove the clutch it is necessary to first remove the engine right side cover.

Clutch friction discs (8—Fig. Y4-19) are 4MM (0.158 in.) thick and should be renewed if less than 3.7MM (0.146 in.) thick. Free length of springs (2) is

34MM (1.34 in.) when new. Springs should be renewed if free length is less than 33MM (1.30 in.). Inspect all parts for wear, warpage and evidence of overheating. Make sure that separator rings (9) are not twisted when installing.

**SPEED TUNING**

A "GYT" kit is offered for the 125cc models. Many features of the "GYT" kit may be incorporated in standard parts. The following specifications may be used as a guide to modify these 125cc models to obtain better performance. Any modification of standard parts or installation of performance parts will void the manufacturers warranty.

Specifications from a 180cc road racing prepared YCS-1 are also listed.

**CARBURETOR.** A pair of 22MM carburetors are recommended for use on 125cc models. The following jet sizes are recommended:

- Main jet ..... #120
  - Pilot jet ..... 30
  - Jet needle ..... 4 D 8
  - Needle jet ..... N-6
- Jet needle clip in second groove from top of needle.

To install the larger carburetors on standard cylinders, it is necessary to cut carburetor mount spigot off and fabricate a new mount spigot. Intake passages should be unobstructed when modifications are completed. Spigot should be installed at an angle that will allow carburetor to clear crankcase.

The YCS1 road racer is equipped with a Mikuni VM 27 SC with a remote float chamber. A carburetor adapter must also be constructed to mount larger (27MM units) on the YCS-1.

**IGNITION.** Use of total loss ignition will yield approximately 3000 rpm increase in engine potential on the 125cc models.

A 100 Twin Jet "GYT" kit magneto may be fitted to 180cc twins with the construction of a special adapter plate.

Standard ignition timing should be used on all models.

**LUBRICATION.** Extended high speed operation (road racing) requires that oil metering pump be set at maximum stroke and a 30:1 fuel to oil mix be used in the fuel tank. Oil mixed in fuel should be same type used in oil tank (air cooled two stroke engine oil).

**CYLINDERS, HEADS AND PISTONS.** Remove 0.062 inch from cylinder heads and reshape taper at edge of combustion chamber. After modification of cylinder heads (for 125cc

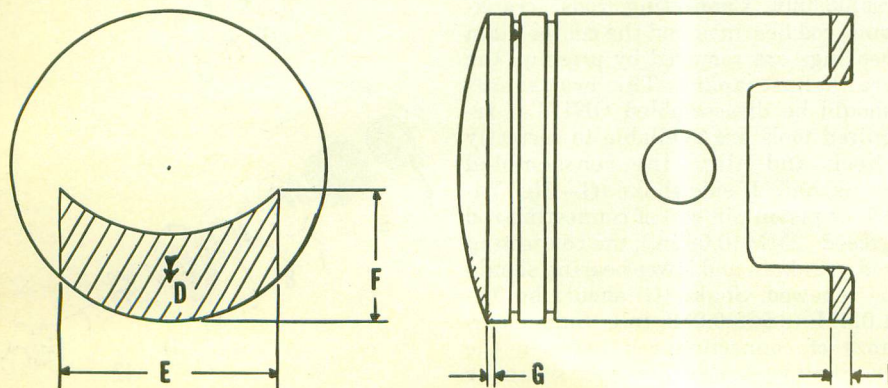

Fig. Y4-1—Areas of piston to be modified. Refer to text for appropriate dimensions.

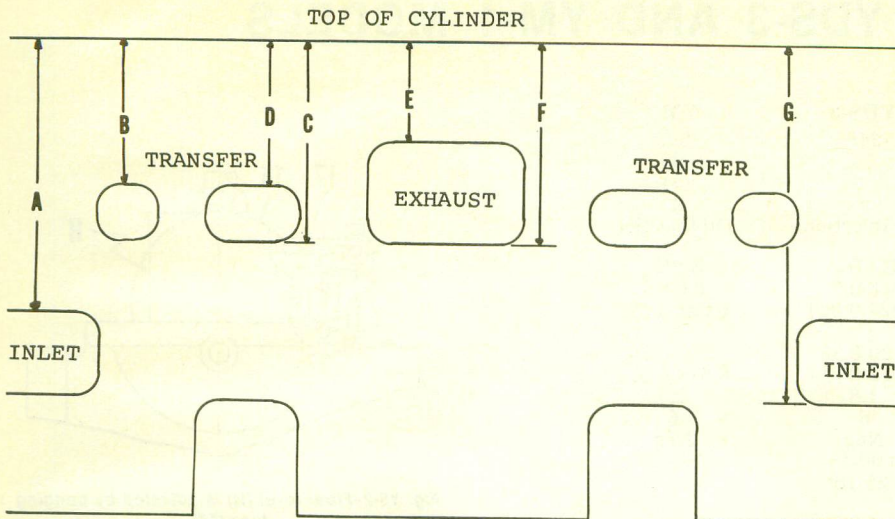

Fig. YT4-2—Diagram of cylinder porting. Take care to radius edges to prevent rings from hanging in ports after cylinder modifications.

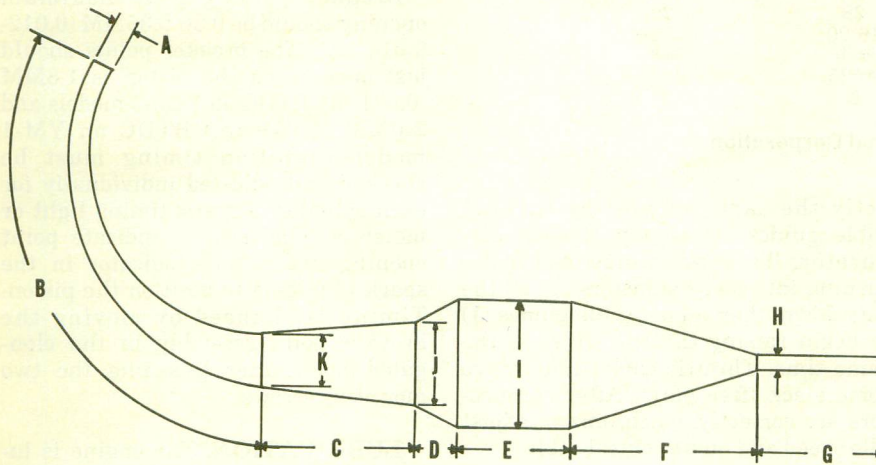

Fig. YT4-3—Basic expansion chamber diagram. Chambers vary greatly from one engine to the next due to type of riding and variations in engine design. Refer to text for dimensions of particular models.

models) the capacity of one head should be 5.8cc.

Pistons (for 125cc models) should use only top (chrome) ring and should have 0.140 inch removed from skirt (I—Fig. YT4-1). All other dimensions remain standard.

Pistons for 180cc models may be modified to road racer specifications by removing 2MM (0.078 inch) of metal from area adjacent to exhaust port (D—Fig. YT4-1). Cut should be 29MM (1.141 inch) wide (E) and should taper back 12MM (0.472 inch) toward center

of piston. Cut should be gradual starting 2MM deep at edge (G) of piston and ending toward center with no metal being removed. Cut 6MM (0.236 inch) from piston skirt (I).

On 125cc models, fabricate a plate 0.062 inch thick using a cylinder base gasket as a template. Remove 0.062 inch from top of cylinder and install the plate with a base gasket on each side of it. This will effectively raise all ports. The following specifications and Fig. YT4-2 will illustrate some other possible modifications:

**AS-1 Road Racer**  
(All dimensions in inches)

- A. 2.164 (Mod.) 2.30 (Std.)
- B. 1.27 (Mod.) 1.29 (Std.)
- D. 1.27 (Mod.) 1.29 (Std.)
- E. 0.885 (Mod.) 0.944 (Std.)
- G. 2.99 (Mod.) 2.87 (Std.)

All other dimensions are left standard.

**AS-1 and AS-2 "GYT" Kit**

- A. 2.165
- C. 1.732
- D. 1.25
- E. 0.874
- F. 1.73
- G. 2.913

Dimension not listed are identical to standard.

The YCS-1 (180cc) road racer had 2MM (0.078 in.) removed from top of exhaust port (E—Fig. YT4-2). All other ports remained unchanged.

**EXPANSION CHAMBER.** The "GYT" kit expansion chambers are available. Similar expansion chambers may be constructed with the following specifications. Refer to Fig. YT4-3.

- A. 35MM (1.378 in.)
- B. 362MM (14.25 in.)
- C. 130MM (5.118 in.)
- D. 20MM (0.787 in.)
- E. 42MM (1.653 in.)
- F. 175MM (6.889 in.)
- G. 208MM (8.189 in.)
- H. 20MM (0.787 in.)
- I. 90MM (3.543 in.)
- J. 90MM (3.543 in.)
- K. 55MM (2.165 in.)

The 180cc YCS-1 road racer used TD1-B (250cc road racer) expansion chamber bodies modified to fit. A suitable high RPM chamber may be constructed with the following specifications: (Refer to Fig. YT4-3)

- A. 40MM (1.574 in.)
- B. 307MM (12.08 in.)
- C. 150MM (5.90 in.)
- D. 55MM (2.165 in.)
- E. 120MM (4.724 in.)
- F. 145MM (5.70 in.)
- G. 200MM (7.87 in.)
- H. 20MM (0.78 in.)
- I. 95.5MM (3.75 in.)
- J. 81.25MM (3.19 in.)
- K. 74.5MM (2.93 in.)

# YAMAHA YDS-3 AND YM-1 MODELS

MODEL	YDS-3	YM-1
Displacement—cc .....	246	305
Bore—MM .....	56	60
Stroke—MM .....	50	54
Number of cylinders .....	2	2
Engine lubrication .....	Oil Injection	Oil Injection
Spark plug—		
NGK .....	B-8HC	B-8HC
Electrode gap—MM .....	0.6-0.7	0.6-0.7
Inch .....	0.024-0.028	0.024-0.028
Ignition—		
Point gap—MM .....	0.30-0.35	0.30-0.35
Inch .....	0.012-0.014	0.012-0.014
Timing—MM BTDC .....	1.8	2.0
Electrical system voltage .....	6	6
Battery terminal grounded .....	Neg	Neg
Tire size—Front .....	3.00-18	3.00-18
Rear .....	3.25-18*	3.25-18
Tire pressure—		
Front—kg/cm <sup>2</sup> .....	1.6	1.6
Psi .....	22	22
Rear—kg/cm <sup>2</sup> .....	2.0	2.0
Psi .....	28	28
Rear chain free play—MM .....	16-20	16-20
Inch .....	5/8-3/4	5/8-3/4
Rear chain size .....	#525	#525
Number of speeds .....	5	5

\*YDS-3C models use 3.50x18 rear tire.

Illustrations courtesy of Yamaha International Corporation

## MAINTENANCE

**SPARK PLUGS.** Recommended spark plug electrode gap is 0.6-0.7MM (0.024-0.028 in.). Suggested spark plug for normal use is NGK type B-8HC. Champion L-5 or L-81 can be used.

**CARBURETORS.** Two Mikuni VM carburetors are used. Idle speed should be set at approximately 1,200 rpm by turning adjusters (2—Fig. Y5-1). Make sure that throttle slides (7) both stop at exactly the same position and exhaust pressure is the same for both cylinders. Idle mixture is changed by turning needles (11). Initial setting is 1½ turns open. Turning the needle counter-clockwise leans the mixture. Carburetors must be synchronized to open ex-

actly the same amount by turning cable guides (1) on top of each carburetor. To synchronize, begin by turning idle speed adjusters (2) all the way down, then adjust cable guides (1) to begin raising throttle slides at the same time. Throttle cables must have some slack (free play). After carburetors are correctly synchronized, adjust idle speed and pump control cable.

Float level (H—Fig. Y5-2) should be 25.5MM (1 in.) and is adjusted by bending tang (17) on float. Refer to Fig. Y5-1 and the following standard specifications:

### YDS-3 and YDS-3C

Main jet (9) ..... #120 or 130  
 Pilot jet (14) ..... #20  
 Needle jet (13) ..... 0-0  
 Valve needle (6) ..... 4D4  
 Clip (5) in second groove from top of needle (6).

### YM-1

Main jet (9) ..... #130  
 Pilot jet (14) ..... #20  
 Needle jet (13) ..... 0-0  
 Valve needle (6) ..... 4D4  
 Clip (5) in second groove from top of needle (6).

### IGNITION AND ELECTRICAL.

All models are equipped with a battery ignition system with an individual set of breaker points, condenser and coil for each cylinder. The generator is mounted at the right end of the crankshaft and the breaker points are mounted on the generator stator.

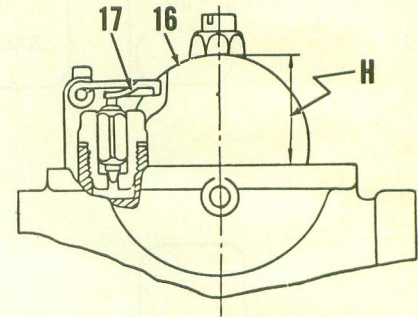

Fig. Y5-2—Float level (H) is adjusted by bending tang (17).

Breaker point gap at maximum opening should be 0.30-0.35MM (0.012-0.014 in.). The breaker points should just open when the piston is 1.8MM (0.071 in.) BTDC on YDS-3 models and 2.0MM (0.079 in.) BTDC on YM-1 models. Ignition timing must be checked and adjusted individually for each cylinder. A static timing light or meter can be used to indicate point opening and a dial indicator in the spark plug hole to position the piston. Timing is changed by moving the breaker point assembly in the elongated holes after loosening the two mounting screws.

**LUBRICATION.** The engine is lubricated by oil contained in a separate tank. A pump and metering unit pumps oil from the tank to each cylinder inlet passage. The oil should **never** be allowed to run dry. SAE 30 two-stroke oil should be used. The oil pump control cable should be accurately adjusted to provide the correct amount of oil. If the cable adjustment is incorrect, the engine may be damaged.

Before adjusting the pump control cable, it is important that the throttle cable guides (1—Fig. Y5-1) are correctly set. To adjust the throttle cable guides, turn the idle speed adjusters (2) all the way down, then synchronize cable guides (1) so that both throttle slides (7) begin to move at exactly the same time when the hand grip is turned. The throttle cables should have approximately 1/16-inch free play after they are synchronized. Adjust the idle speed to 1,100-1,300 rpm by turning both idle adjusters (2). Make certain that both throttle slides stop at exactly the same time. Turn the throttle hand grip just enough to take up free play from the throttle cables (without changing idle speed) and check the oil pump setting mark and guide pin as

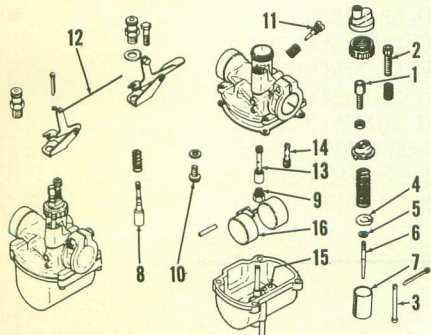

Fig. Y5-1—Exploded view of Mikuni VM carburetor. Starting valves for both carburetors are connected with rod (12).

- |                         |                         |
|-------------------------|-------------------------|
| 1. Throttle cable guide | 9. Main jet             |
| 2. Idle speed adjuster  | 10. Fuel inlet valve    |
| 3. Idle speed rod       | 11. Idle mixture needle |
| 4. Retainer             | 12. Link rod            |
| 5. Clip                 | 13. Needle jet          |
| 6. Valve needle         | 14. Pilot jet           |
| 7. Throttle slide       | 15. Starting jet        |
| 8. Starting valve       | 16. Float               |

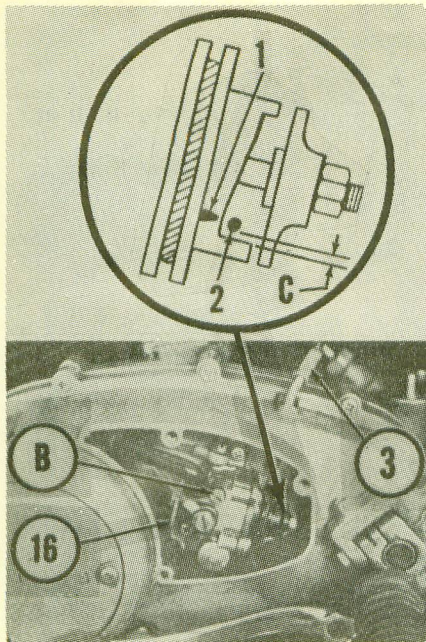

Fig. Y5-5—When carburetor controls are correctly adjusted and engine is at idle speed, mark (1) should be aligned with guide pin (2). Cable adjuster is shown at (3). Clearance (C) at idle should be 0.35-0.40MM.

shown in Fig. Y5-5. If the "V" mark (1) is not exactly aligned with guide pin (2); loosen the lock nut and turn the pump cable adjuster (3) as required for alignment.

Check the minimum plunger stroke by turning starter plate (16—Fig. Y5-5) until clearance (A—Fig. Y5-7) between pulley and adjusting plate is at minimum. Clearance (A) should be 0.25-0.35MM (0.0098-0.0138 inch). If clearance is incorrect, add or deduct shims (8).

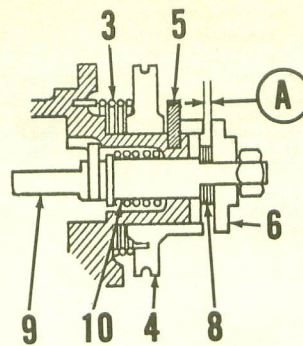

Fig. Y5-7—Clearance (A) should be 0.25-0.35MM and is adjusted by varying shims (8).

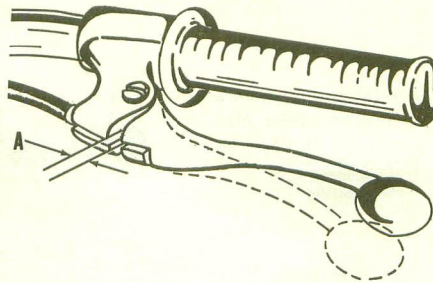

Fig. Y5-9—The clutch hand lever should have 2-3MM free play at (A).

If oil lines are drained or pump is removed, it is important that all lines be filled before starting engine. Remove bleeder screw (B—Fig. Y5-5) and pull the control cable up out of cable guide (3). Turn starter plate (16) until oil without air bubbles flows from the bleeder screw hole, then reinstall bleeder screw (B) and start engine. Run engine at idle speed until oil delivery lines (20—Fig. Y5-6) are free of air bubbles.

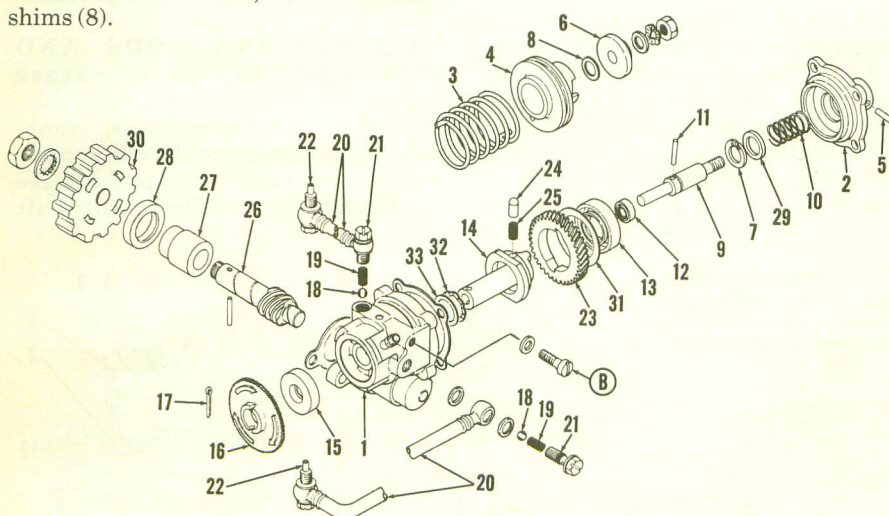

Fig. Y5-6—Exploded view of the oil injection pump unit. Bleeder screw is shown at (B).

- |                  |                           |                    |                      |
|------------------|---------------------------|--------------------|----------------------|
| 1. Pump case     | 10. Plunger return spring | 17. Drive pin      | 25. Spring           |
| 2. Cover         | 11. Cam guide pin         | 18. Check balls    | 26. Worm shaft       |
| 3. Pulley spring | 12. Plunger oil seal      | 19. Springs        | 27. Bushing          |
| 4. Adjust pulley | 13. Plunger cam oil seal  | 20. Delivery pipes | 28. Oil seal         |
| 5. Guide pin     | 14. Distributor           | 21. Banjo bolts    | 29. Spring seat      |
| 6. Adjust plate  | 15. Oil seal              | 22. Injector bolt  | 30. Drive gear       |
| 7. Snap ring     | 16. Starter plate         | 23. Worm wheel     | 31. Worm wheel plate |
| 8. Shims         |                           | 24. Worm wheel pin | 32. Wave washer      |
|                  |                           |                    | 33. Plate            |

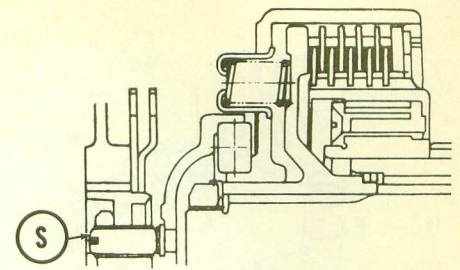

Fig. Y5-10—The clutch adjusting screw (S) is located under the small, round cover on engine left side cover.

The gear box contains 1.7 quarts of SAE 30 or 10W/30 motor oil and should be drained and refilled every 2000 miles.

**CLUTCH CONTROLS.** The clutch hand lever should have 1/16-1/8 inch free play at (A—Fig. Y5-9). To adjust, remove the cover from left side of engine and loosen lock nut. Turn the adjusting screw (S—Fig. Y5-10) in until slight resistance is felt, then back screw out 1/4 turn and tighten lock nut. Turn the cable guide at ends of cable until the hand lever free play (A—Fig. Y5-9) is correct.

**SUSPENSION.** Each front suspension unit contains 200cc of oil. The oil used should be a mixture of 80% SAE 30 motor oil and 20% SAE 60 spindle oil. Oil should be renewed every 4,000 miles.

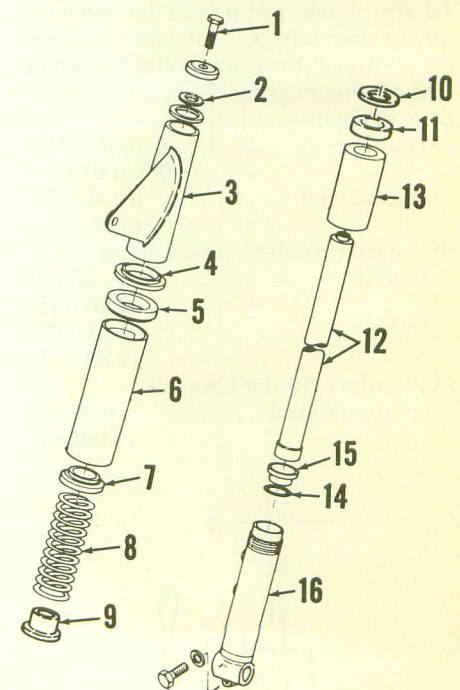

Fig. Y5-12—Exploded view of the front suspension system.

- |                 |                |
|-----------------|----------------|
| 1. Filler screw | 9. Spring seat |
| 2. Seal         | 10. Washer     |
| 3. Cover        | 11. Oil seal   |
| 4. Guide        | 12. Inner tube |
| 5. Washer       | 13. Tube nut   |
| 6. Cover        | 14. "O" ring   |
| 7. Spring seat  | 15. Bushing    |
| 8. Spring       | 16. Lower tube |

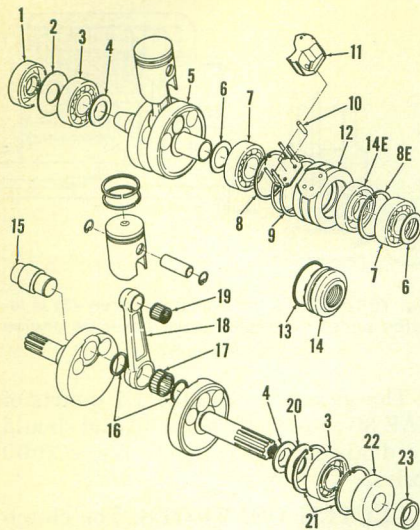

Fig. Y5-14—Exploded view of the crankshaft assembly. Parts (8E & 14E) should be discarded if later type seal (13 & 14) is installed.

- |                                   |                                   |
|-----------------------------------|-----------------------------------|
| 1. Oil seal                       | 13. "O" ring (late type)          |
| 2. Bearing cover                  | 14. Center seal (late type)       |
| 3. Main bearings                  | 14E. Center seal (early lip type) |
| 4. Shims                          | 15. Crankpin                      |
| 5. Crankshaft right cylinder half | 16. Crankpin washers              |
| 6. Shims                          | 17. Crankpin bearing              |
| 7. Center main bearings           | 18. Connecting rod                |
| 8. Snap ring                      | 19. Piston pin bearing            |
| 8E. Snap ring (early models)      | 20. Shim                          |
| 9. Gasket                         | 21. Snap ring                     |
| 10. Pin                           | 22. Oil seal                      |
| 11. Filler piece                  | 23. Collar                        |

**REPAIRS**

**PISTONS, RINGS AND CYLINDERS.** Each piston can be removed after removing exhaust pipe, carburetor, cylinder head and cylinder. Refer to the following specifications:

- Ring end gap—
- Top ring ..... 0.15-0.30MM (0.006-0.012 in.)
  - Second ring ..... 0.1-0.2MM (0.004-0.008 in.)
- Standard cylinder bore diameter
- YDS-3 ..... 56MM (2.20 inch)
  - YM-1 ..... 60MM (2.36 inch)
- Maximum cylinder bore taper or out of round ..... 0.05MM (0.002 in.)

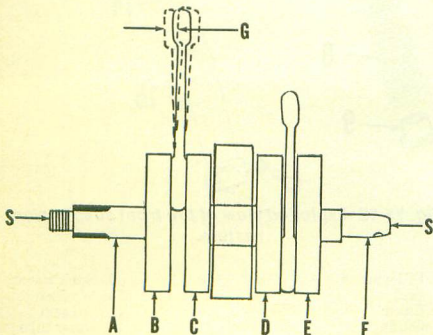

Fig. Y5-15—Refer to text to check crankshaft for correct assembly or wear.

Fig. Y5-16—Exploded view of the clutch assembly. Parts (1, 2 & 3) are located in the left cover.

1. Adjusting screw
2. Return spring
3. Release lever and screw
4. Push crown
5. Release bearing
6. Nut
7. Lock plate
8. Clutch drum
9. Spring cup
10. Spring
11. Drive plate
12. Friction discs (5 used)
13. Clutch plate (4 used)
14. Clutch plate (thick)
15. Snap ring
16. Thrust washers
17. Inner thrust washer
18. Primary drive gear bearing
19. Clutch hub and primary drive gear
20. Thrust washer (larger I.D.)
21. Thrust washer (small I.D.)

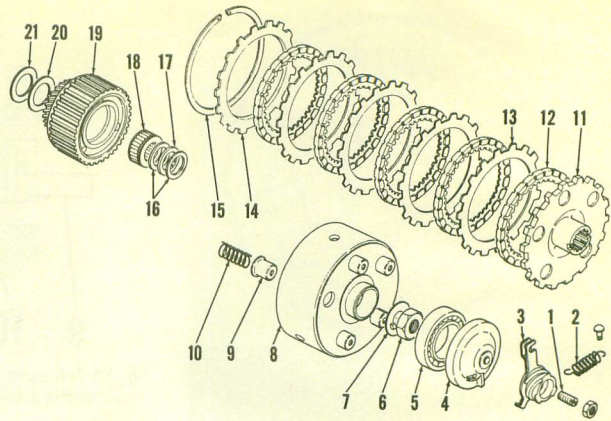
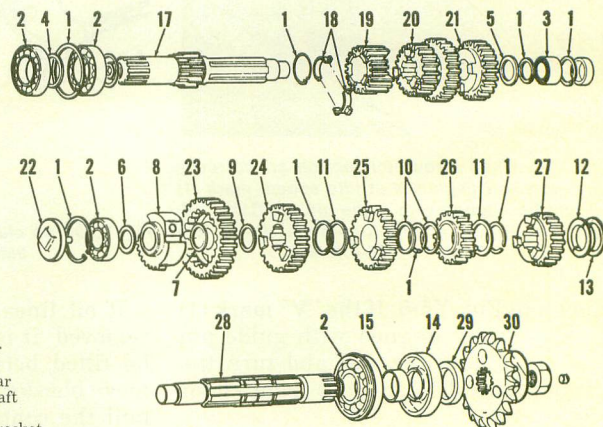

Fig. Y5-19—Exploded view of transmission. Refer also to Fig. Y5-20.

1. Snap rings
2. Ball bearings
3. Needle bearing
4. Spacer
5. Washer
6. Shim
7. Thrust washer
8. Kick starter pinion
9. Spacer
10. Washers
11. Washers
12. Setting plate
13. Shim
14. Oil seal
15. Collar
17. Input shaft
18. Setting plate
19. Second gear
20. Third & fifth gear
21. Fourth gear
22. Oil catcher
23. First gear
24. Second gear
25. Third gear
26. Fifth gear
27. Fourth gear
28. Output shaft
29. Spacer
30. Output sprocket



Piston skirt to cylinder clearance—

- YDS-3 ..... 0.050-0.055MM (0.0020-0.0022 in.)
- YM-1 ..... 0.054-0.058MM (0.0021-0.0023 in.)

Piston skirt clearance in cylinder bore should be measured by first measuring piston diameter at right angles to piston pin and cylinder bore diameter, then subtracting. The piston should be measured 10MM (0.4 inch) above bottom edge of skirt. The dark piston ring should be installed in lower groove and chrome plated ring should

be in top groove. Make sure that rings correctly engage pins in the ring grooves. Pistons should be installed on connecting rods with arrow pointing toward front. Cylinder head stud nuts should be torqued to 180 inch-pounds.

**CONNECTING RODS AND CRANKSHAFT.**

The crankcase halves must be separated to remove the crankshaft. Connecting rods, crankpins, rod bearings and the center main bearings are removed by pressing the crankshaft apart. The crankshaft

Fig. Y5-20—Cross sectional view of the transmission assembly showing location of spacers and washers.

1. Snap rings
2. Ball bearings
3. Needle bearing
4. Spacer (1.8MM)
5. Washer (1.0MM)
6. Shim
7. Thrust washer O.D. 26MM (1.0MM thick)
8. Kickstarter pinion
9. Spacer O.D. 28MM (1.0MM thick)
10. Washers O.D. 32MM (1.0MM thick)
11. Washer O.D. 26MM (1.0MM thick)
12. Setting plate
13. Shim O.D. 34MM (1.2MM thick)
14. Oil seal
15. Collar

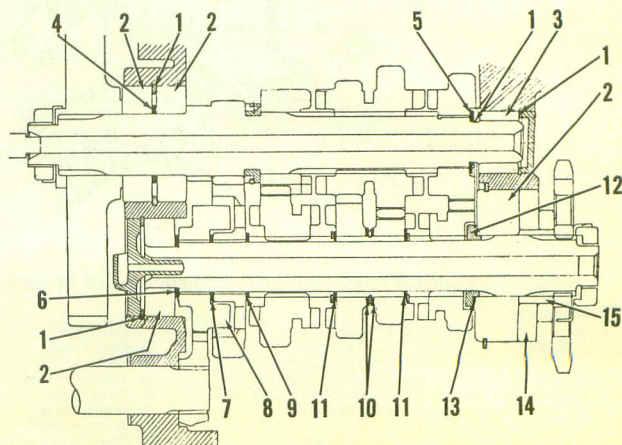

should be disassembled **ONLY** if required tools are available to correctly check and align the reassembled crankshaft. If side shake (G—Fig. Y5-15) at piston pin end of connecting rod exceeds 2MM (0.08 in.), the connecting rod, crankpin and lower bearing should be renewed. Shake (G) should be 0.8-1.0MM (0.032-0.039 in.). Side clearance of connecting rod between the crankshaft counter weights can be measured with a feeler gage. Side clearance should be 0.1-0.3MM

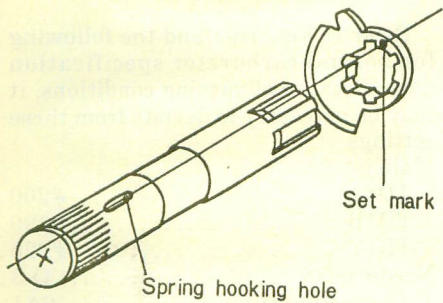

Fig. Y5-21—Mark on kickstarter gear should be aligned with spring hooking hole as shown.

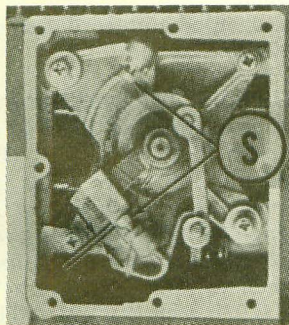

Fig. Y5-22—Gear change stop bolts (S) should have approximately 1MM clearance when stop ball engages detent in shifter cam.

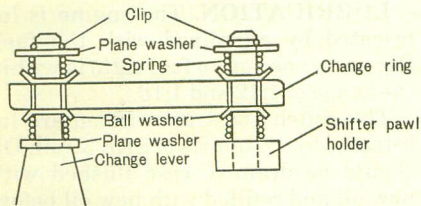

Fig. Y5-23—View of shift change ring installation.

(0.0039-0.012 in.). With crankshaft supported between lathe centers (S—Fig. Y5-15), maximum eccentricity when measured with dial indicator at points (A & F) should not exceed 0.03MM (0.0012 in.) and should not exceed 0.06MM (0.0024 in.) at points (B, C, D & E).

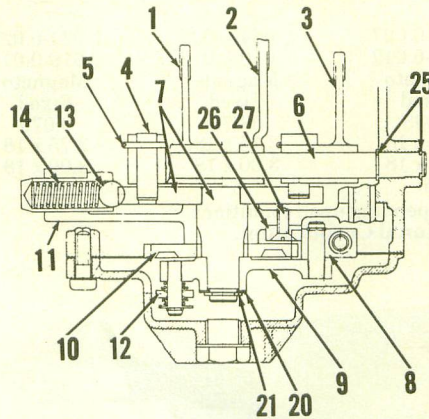
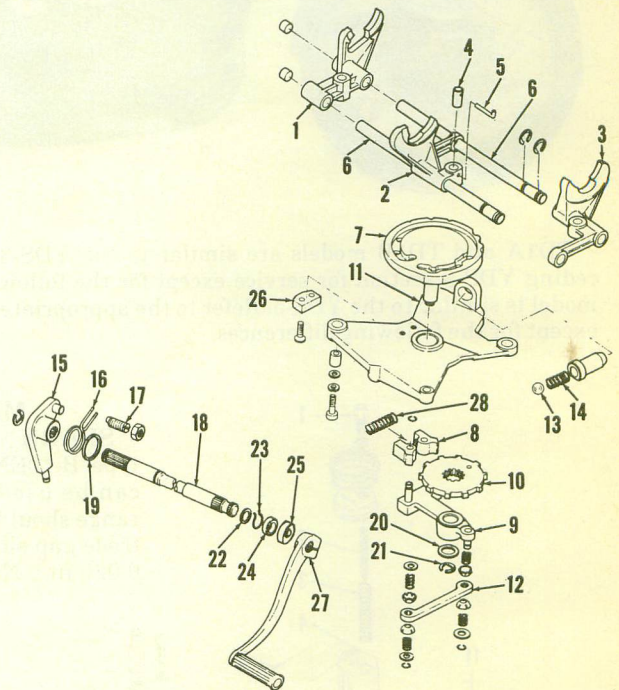

Fig. Y5-24—Cross sectional view of the shift assembly. Refer to Fig. Y5-25 for legend.

Fig. Y5-25—Exploded view of shift assembly. Shift fork (1) moves gear (26—Fig. Y5-19), fork (2) moves gear (20—Fig. Y5-19) and fork (3) moves gear (24—Fig. Y5-19).

1. Shift fork (5th)
2. Shift fork (2nd & 4th)
3. Shift fork (1st & 3rd)
4. Shift rotor (3 used)
5. Stop pin (3 used)
6. Shift rails
7. Shift cam
8. Shifter pawls
9. Pawl holder
10. Working plate
11. Mounting plate
12. Change link
13. Cam detent ball
14. Detent spring
15. Change lever
16. Return spring
17. Eccentric screw
18. Shift pedal shaft
19. Washer
20. Shims
21. Snap ring
22. Washer
23. Snap ring
24. Oil seal
25. Seal
26. Pawl plate
27. Shift pedal
28. Shift pawl spring



**CLUTCH.** The multiple disc wet type clutch is located on the left end of the crankshaft. The clutch can be removed after removing the engine left side cover and the clutch retaining nut (6—Fig. Y5-16).

Clutch friction discs (12) should be renewed if less than 4MM (0.158 in.) thick. Thickness when new is 4.3MM (0.169 in.). Free length of clutch springs (10) should be 25.4MM (1 in.). Springs should be renewed if less than 23.5MM (0.925 in.). Inspect all parts for wear, warpage or evidence of overheating.

**CRANKCASE AND GEAR BOX.** The 5 speed transmission is shown in Figs. Y5-19 and Y5-20. The kickstarter gear should be installed on shaft with mark on gear aligned with spring hooking hole as shown in Fig. Y5-21. Shifter stop bolts (S—Fig. Y5-22) should have approximately 1MM (0.04 in.) clearance as the stop ball falls into detent in the cam.

# YAMAHA TD-1 MODELS

MODEL	TD1A	TD1B	TD1C
Displacement—cc	246	246	246
Bore—MM	56	56	56
Stroke—MM	50	50	50
Number of cylinders	2	2	2
Oil-fuel ratio		*	*
Plug gap—inch	0.024-0.027	0.024-0.027	0.024-0.027
Point gap—inch	0.010-0.012	0.010-0.012	0.010-0.012
Ignition—type	Magneto	Magneto	Magneto
Timing	Fixed	Fixed	Fixed
Piston position BTDC—inch	0.083	0.079	0.079
Tire size—front	2.50 x 18	2.75 x 18	2.75 x 18
Rear	2.75 x 18	3.00 x 18	3.00 x 18
Number of speeds	5	5	5

\*Oil to fuel ratio should be from 1:12 to 1:16 depending upon conditions.  
 Illustrations courtesy of Yamaha International Corporation.

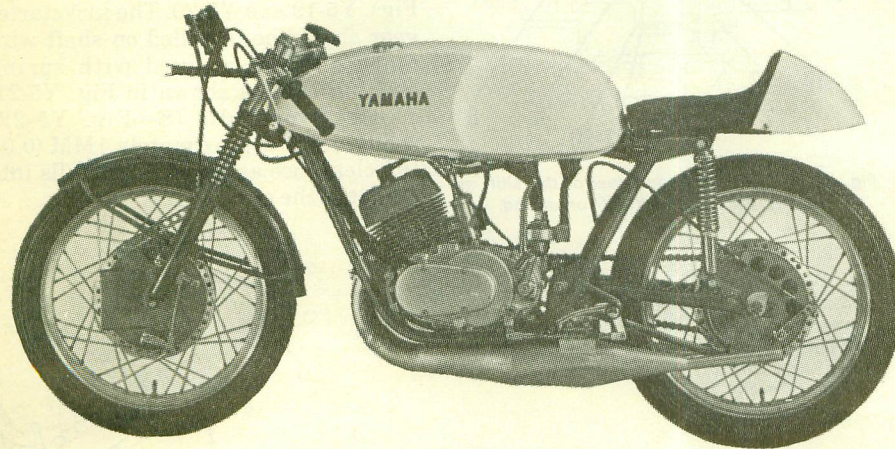

TD1A and TD1B models are similar to the YDS-3 models. Refer to the preceding YDS-3 section for service except for the following differences. The TD1C model is similar to the YDS-5. Refer to the appropriate (YDS-5) section for service except for the following differences.

spark plugs can be used to warm up engine.

**CARBURETORS.** Two Mikuni VM 276 carburetors are used with a remote float chamber for each. Make certain that carburetors are perfectly synchronized to open exactly alike when the throttle is opened.

Refer to Fig. Y6-1 and the following for normal carburetor specification data. Because of varying conditions, it may be necessary to deviate from these settings.

- Main jet (9)—
- TD1A ..... #200
  - TD1B ..... #190
  - TD1C ..... #220
- Needle jet (8) ..... Q-3  
 Valve needle (7) ..... 6A1  
 Pilot jet ..... #25  
 Initial setting of needle (11) is 1¼-1½ turns open.  
 Clip (6) should be in third groove from top of needle (7).

**IGNITION.** The ignition system magneto is mounted at the right end of the crankshaft. Refer to Fig. Y6-2 for exploded view. Breaker point gap at maximum opening should be 0.010-0.012 inch (0.25-0.30MM). Breaker points should just open when piston is 0.083 inch (2.1MM) BTDC on TD1A models; 0.079 inch (2.0MM) BTDC on TD1B and TD1C models. Timing is set individually for each cylinder and should be exactly alike.

**LUBRICATION.** The engine is lubricated by oil mixed with the fuel. Recommended oil to fuel ratio is within the range of 1:12 and 1:16.

The clutch and transmission are lubricated by 1½ quarts of SAE 30 oil. Oil should be drained, case flushed with new oil and refilled with new oil before each race. Make certain that drain plug is safetied with wire.

**SUSPENSION.** Type and quantity of oil in the front suspension will depend upon conditions. Normal capacity is 195cc (6.6 fl. oz.) in each unit.

**SPECIAL NOTES.** It is important that all screws and nuts are secured with safety wire, lock plates, lock washers or locking compound (such as Locktite). All parts should be checked often for security.

Be extremely careful when servicing with fuel (and oil mixture). Filters should be used when filling to prevent foreign matter from entering tank.

## MAINTENANCE

**SPARK PLUG.** Normally NGK type B-10EN or B-11EN spark plugs can be used; however, specific heat range should be chosen carefully. Electrode gap should be 0.6-0.7MM (0.024-0.027 in.). NGK type B-8HN or B-8HC

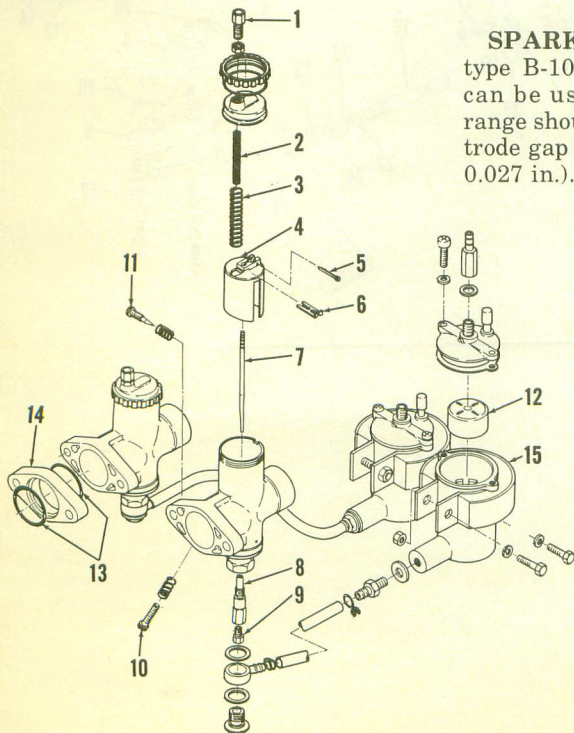

Fig. Y6-1—Exploded view of Mikuni VM 276 carburetors and float bowls.

1. Throttle cable guide
2. Throttle spring
3. Throttle spring
4. Throttle slide
5. Cotter pin
6. Clip
7. Valve needle
8. Needle jet
9. Main jet
10. Idle speed screw
11. Idle mixture needle
12. Float
13. "O" ring
14. Insulator
15. Float chamber holder

REPAIRS

**PISTONS, RINGS AND CYLINDERS.** Only one ring is used on each piston. The clearance between the piston and cylinder should be checked by measuring piston diameter at skirt at right angles to piston pin and cylinder diameter, then subtracting. Clearance should be 0.060-0.065MM (0.0024-0.0026 in.) for TD1A; 0.045-0.050MM (0.0018-0.0020 in.) for TD1B and TD1C. The pistons used in the TD1-B are 9MM (0.35 in.) shorter than YDS-3 pistons.

When breaking in, the pistons should be removed after short running and checked for any polished surfaces. If piston contacts cylinder wall, surface of piston will be polished and should be smoothed with #400 or #600 sandpaper. Clean thoroughly and reassemble. Be sure to use new piston pin retaining snap rings and make sure that rings fully engage grooves in piston bores.

**CLUTCH.** The clutch on TD1A and TD1B models is mounted on the left end of the crankshaft and is similar to YDS-3 models. Refer to the preceding YDS-3 section regarding service on TD1A and TD1B models.

The clutch on TD1C models is mounted on the left end of the transmission input shaft and is similar to YDS-5 models. Refer to the YDS-5 section regarding service on TD1C models.

**EXPANSION CHAMBER.** An expansion chamber with the characteristics of the 1968 Daytona road racer may be constructed with the following specifications. (Refer to Fig. Y6-4).

- A. 40MM (1.574 in.)
- B. 307MM (12.08 in.)
- C. 193MM (7.598 in.)
- D. 55MM (2.165 in.)
- E. 159MM (6.259 in.)
- F. 178MM (7.00 in.)
- G. 173MM (6.811 in.)
- H. 20MM (0.787 in.)
- I. 95.5MM (3.75 in.)
- J. 81.25MM (3.20 in.)
- K. 75.4MM (2.97 in.)

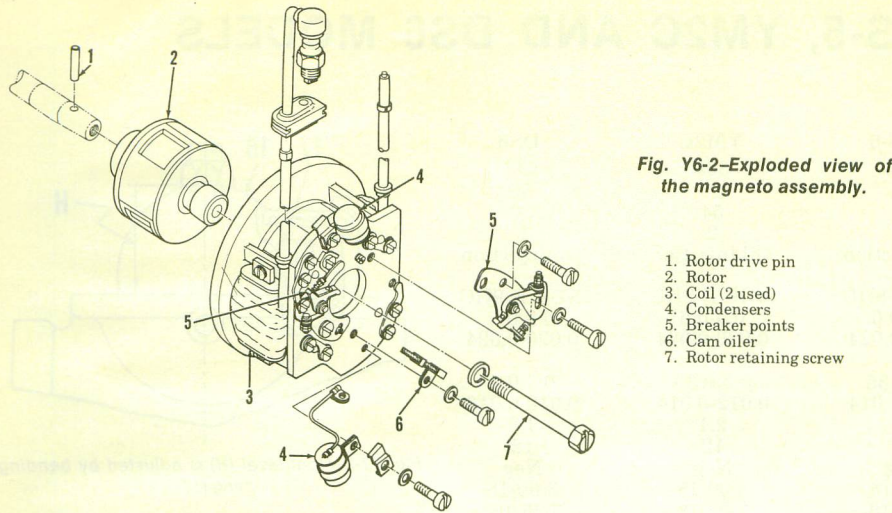

Fig. Y6-2—Exploded view of the magneto assembly.

- 1. Rotor drive pin
- 2. Rotor
- 3. Coil (2 used)
- 4. Condensers
- 5. Breaker points
- 6. Cam oiler
- 7. Rotor retaining screw

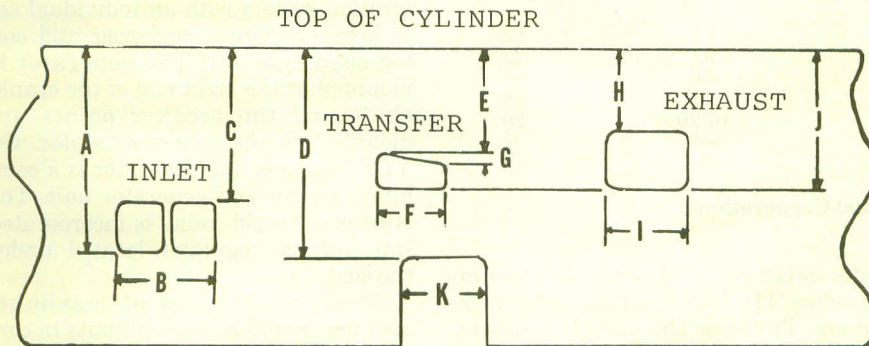

Fig. Y6-3—Diagram of cylinder porting common to TD-1 models. These dimensions were taken from the 1968 TD1-B Daytona road racer.

- A. 3.375 in. (86MM)
- B. 1.417 in. (36MM)
- C. 2.438 in. (62MM)
- D. 3.687 in. (94MM)
- E. 1.456 in. (37MM)
- F. 0.900 in. (23MM)
- G. 0.059 in. (1.5MM)
- H. 1.060 in. (27MM)
- I. 1.456 in. (37MM)
- J. 1.968 in. (50MM)
- K. 1.259 in. (32MM)

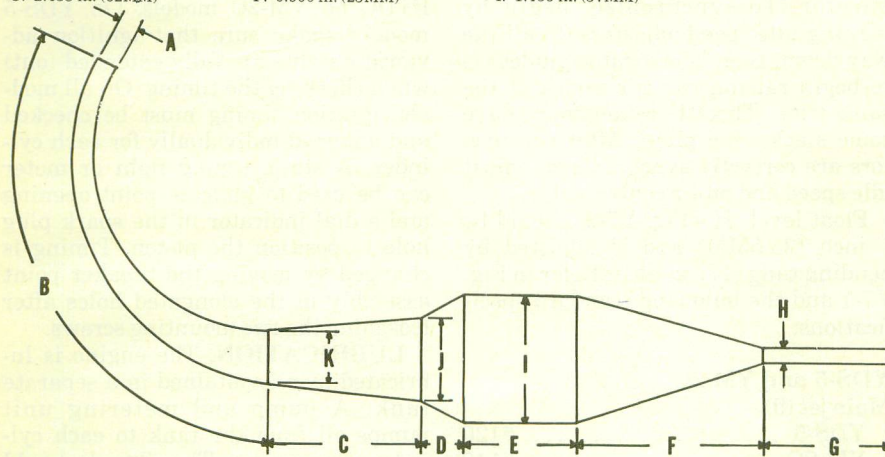

Fig. Y6-4—Basic diagram of TD-1 expansion chamber. Refer to text for specifications.

# YAMAHA YDS-5, YM2C AND DS6 MODELS

MODEL	YDS-5	YM2C	DS6
Displacement—cc	246	305	246
Bore—MM	56	60	56
Stroke—MM	50	54	50
Number of cylinders	2	2	2
Engine lubrication	Oil Injection	Oil Injection	Oil Injection
Spark plug—			
Type	NGK B-8HC	NGK B-8HC	NGK B-9HC
Electrode gap—MM	0.5-0.6	0.5-0.6	0.5-0.6
Inch	0.020-0.024	0.020-0.024	0.020-0.024
Ignition—			
Point gap—MM	0.3-0.35	0.3-0.35	0.3-0.4
Inch	0.012-0.014	0.012-0.014	0.012-0.016
Timing—MM BTDC	1.8	2.1	1.8
Electrical system voltage	12	12	12
Battery terminal grounded	Neg	Neg	Neg
Tire size—Front	3.00-18	3.00-18	3.00-18
Rear	3.25-18	3.25-18	3.25-18*
Tire pressure—			
Front—kg/cm <sup>2</sup>	1.5	1.5	1.6
Psi	22	22	23
Rear—kg/cm <sup>2</sup>	2.0	2.0	2.0
Psi	28	28	28
Rear chain free play—MM	16-20	16-20	20
Inch	5/8-3/4	5/8-3/4	3/4
Number of speeds	5	5	5

\*Rear tire on DS6C is 3.50-18

Illustrations courtesy of Yamaha International Corporation

## MAINTENANCE

**SPARK PLUGS.** Recommended spark plug electrode gap is 0.5-0.6MM (0.020-0.024 in.). DS6 models should be equipped with NGK type B-9HC spark plugs for normal use. All other models use NGK type B-8HC. Champion L57R can be used in DS6 models and Champion L60R for other models.

**CARBURETORS.** Two Mikuni VM carburetors are used. Idle speed should be set at approximately 1,200 rpm by turning adjusters (2—Fig. Y7-1). Make sure that throttle slides (7) both stop at exactly the same position and exhaust pressure is the same for both cylinders.

Idle mixture is changed by turning needles (11). Initial setting is 1½ turns open. Turning the needle counter-clockwise leans the mixture. Carburetors must be synchronized to open exactly the same amount by turning cable guides (1) on top of each carburetor. To synchronize, begin by turning idle speed adjusters (2) all the way down, then adjust cable guides (1) to begin raising throttle slides at the same time. Throttle cables must have some slack (free play). After carburetors are correctly synchronized, adjust idle speed and pump control cable.

Float level (H—Fig. Y7-2) should be 1 inch (25.5MM) and is adjusted by bending tang (17) on float. Refer to Fig. Y7-1 and the following standard specifications:

### YDS-5 and YM-2C

Main jet (9)—  
 YDS-5 ..... #120  
 YM-2C ..... #110  
 Pilot jet (14) ..... #30  
 Needle jet (13) ..... 0-5  
 Valve needle (6) ..... 4D3  
 Clip (5) in second groove from top of needle (6).

### DS6

Main jet (9) ..... #110  
 Pilot jet (14) ..... #30  
 Needle jet (13) ..... N-8  
 Valve needle (6) ..... 4D3  
 Clip (5) in the third groove from the top of needle (6).

### IGNITION AND ELECTRICAL.

All models are equipped with a battery

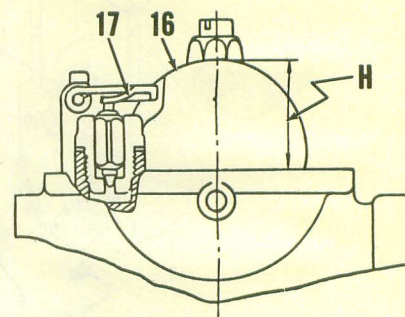

Fig. Y7-2—Float level (H) is adjusted by bending tang (17).

ignition system with an individual set of breaker points, condenser and coil for each cylinder. The generator is mounted at the right end of the crankshaft and the breaker points are mounted on the generator stator. On YDS-5 models, the generator is a combined starter and generator unit. The starter (solenoid) relay is incorporated into voltage regulator located under the seat.

Breaker point gap at maximum opening should be within limits in condensed data table. The breaker points should just open when the piston is 1.8MM (0.071 in.) BTDC on YDS-5 and DS6 models and 2.1MM (0.083 in.) BTDC on YM-2C models. On YDS-5 models, make sure that ignition advance weights are fully extended (out) when checking the timing. On all models, ignition timing must be checked and adjusted individually for each cylinder. A static timing light or meter can be used to indicate point opening and a dial indicator in the spark plug hole to position the piston. Timing is changed by moving the breaker point assembly in the elongated holes after loosening the two mounting screws.

**LUBRICATION.** The engine is lubricated by oil contained in a separate tank. A pump and metering unit pumps oil from the tank to each cylinder inlet passage. The oil tank should never be allowed to run dry. SAE 30 two-stroke oil should be used. The oil pump control cable should be accurately adjusted to provide the correct amount of oil. If the cable adjustment is incorrect, the engine may be damaged.

Before adjusting the pump control cable, it is important that the throttle cable guides (1—Fig. Y7-1) are correctly set. To adjust the throttle cable guides, turn the idle speed adjusters (2) all the way down, then synchronize cable guides (1) so that both the throttle slides (7) begin to move at exactly the same time when the hand grip is turned. The throttle cables

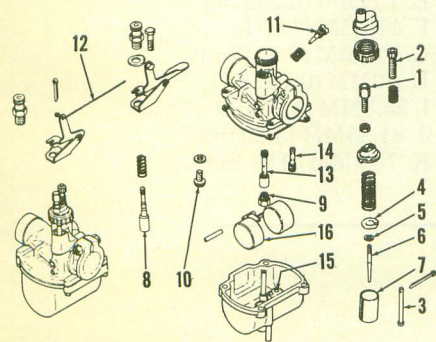

Fig. Y7-1—Exploded view of Mikuni VM carburetor. Starting valves for both carburetors are connected with rod (12).

1. Throttle cable guide
2. Idle speed adjuster
3. Idle speed rod
4. Retainer
5. Clip
6. Valve needle
7. Throttle slide
8. Starting valve
9. Main jet
10. Fuel inlet valve
11. Idle mixture needle
12. Link rod
13. Needle jet
14. Pilot jet
15. Starting jet
16. Float

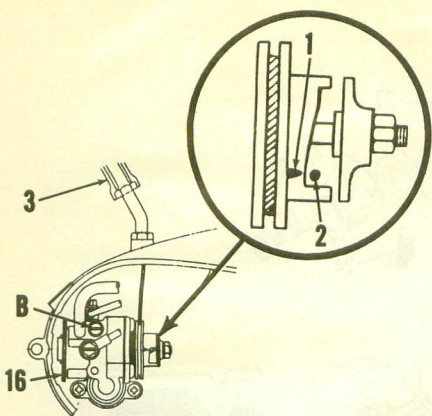

Fig. Y7-5—When carburetor controls are correctly adjusted and engine is at idle speed, mark (1) should be aligned with guide pin (2). Cable adjuster is shown at (3).

should have approximately 1/16-inch free play after they are synchronized. Adjust the idle speed to 1,100-1,300 rpm by turning both idle adjusters (2). Make certain that both throttle slides stop at exactly the same time. Turn the throttle hand grip just enough to take up free play from the throttle cables (without changing idle speed) and check the oil pump setting mark and guide pin as shown in Fig. Y7-5. If the "V" mark (1) is not exactly aligned with guide pin (2); loosen the lock nut and turn the pump cable adjuster (3) as required for alignment.

Check the minimum plunger stroke by turning starter plate (16) until clearance (A)—Fig. Y7-7 between pulley and adjusting plate is at minimum. Clearance (A) should be 0.20-0.25MM (0.008-0.0098 inch) on DS6 models and 0.25-0.35MM (0.0098-0.013

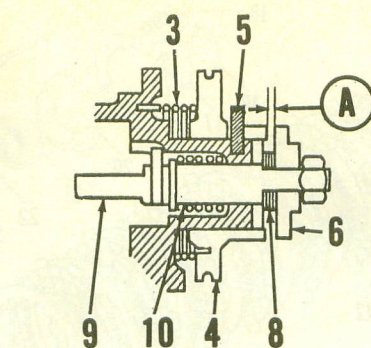

Fig. Y7-7—Clearance (A) is adjusted by varying shims (8).

inch) on all others. If clearance is incorrect, add or deduct shims (8).

If oil lines are drained or pump is removed, it is important that all lines be filled, before starting engine. Remove bleeder screw (B—Fig. Y7-5) and pull the control cable up out of cable guide (3). Turn starter plate (16) until oil without air bubbles flows from the bleeder screw hole, then reinstall bleeder screw (B) and start engine. Run engine at idle speed until oil delivery lines (20—Fig. Y7-6) are free of air bubbles.

The gear box contains 1¼ quarts of SAE 30 or 10W/30 motor oil and should be drained and refilled every 1200 miles.

**CLUTCH CONTROLS.** The clutch hand lever should have 1/16-1/8 inch free play at (A—Fig. Y7-9). To adjust, remove the cover from left side of engine and loosen lock nut. Turn the adjusting screw (S—Fig. Y7-10) in until slight resistance is felt, then back screw out ¼ turn and tighten lock nut.

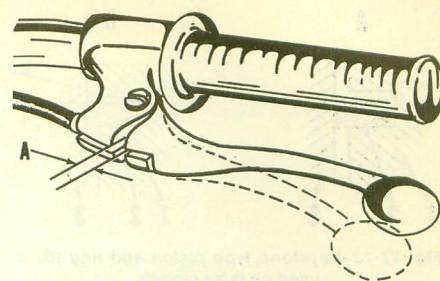

Fig. Y7-9—The clutch hand lever should have 2-3mm free play at (A).

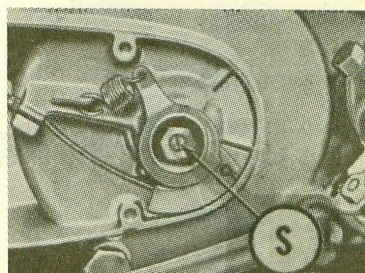

Fig. Y7-10—The clutch adjusting screw (S) is located under the cover on left side of engine.

Turn the cable guide at hand lever end of cable until the hand lever free play (A—Fig. Y7-9) is correct.

**SUSPENSION.** Each front suspension unit contains 200cc of oil. The oil used should be a mixture of 80% SAE 30 motor oil and 20% SAE 60 spindle oil. Oil should be renewed every 2,000 miles.

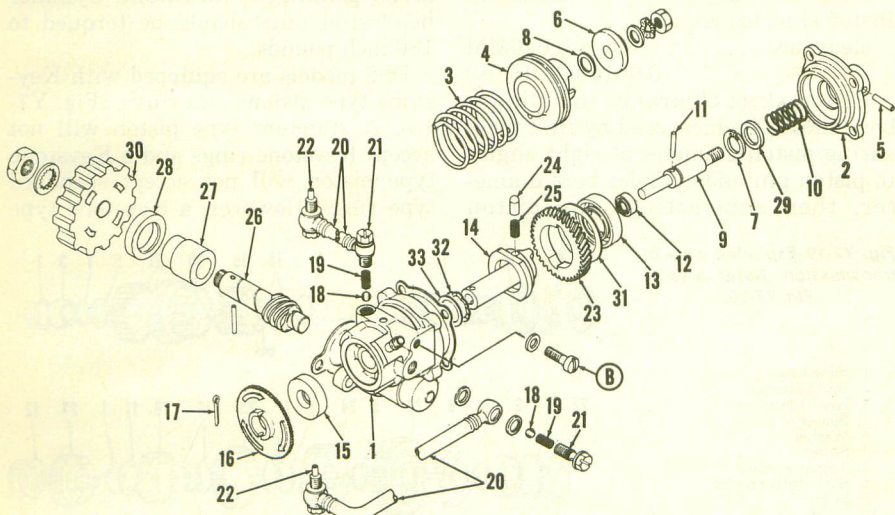

Fig. Y7-6—Exploded view of the oil injection pump unit.

- |                  |                           |                    |                      |
|------------------|---------------------------|--------------------|----------------------|
| 1. Pump case     | 10. Plunger return spring | 17. Drive pin      | 25. Spring           |
| 2. Cover         | 11. Cam guide pin         | 18. Check balls    | 26. Worm shaft       |
| 3. Pulley spring | 12. Plunger oil seal      | 19. Springs        | 27. Bushing          |
| 4. Adjust pulley | 13. Plunger cam oil seal  | 20. Delivery pipes | 28. Oil seal         |
| 5. Guide pin     | 14. Distributor           | 21. Banjo bolts    | 29. Spring seat      |
| 6. Adjust plate  | 15. Oil seal              | 22. Injector bolt  | 30. Drive gear       |
| 7. Snap ring     | 16. Starter plate         | 23. Worm wheel     | 31. Worm wheel plate |
| 8. Shims         |                           | 24. Worm wheel pin | 32. Wave washer      |
| 9. Plunger       |                           |                    | 33. Plate            |

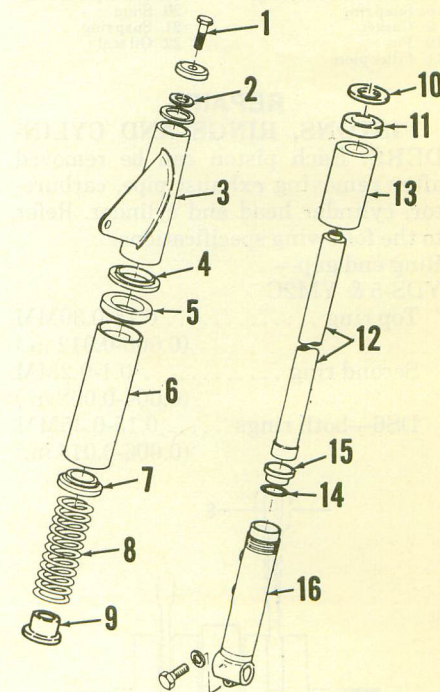

Fig. Y7-12—Exploded view of the front suspension system.

- |                 |                |
|-----------------|----------------|
| 1. Filler screw | 9. Spring seat |
| 2. Seal         | 10. Washer     |
| 3. Cover        | 11. Oil seal   |
| 4. Guide        | 12. Inner tube |
| 5. Gasket       | 13. Tube nut   |
| 6. Cover        | 14. "O" ring   |
| 7. Spring seat  | 15. Bushing    |
| 8. Spring       | 16. Lower tube |

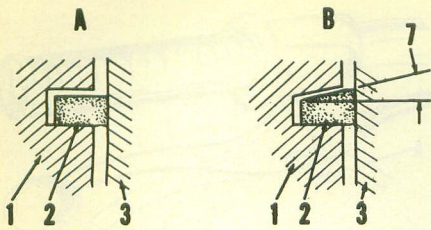

Fig. Y7-13—Keystone type piston and ring (B) is used on later models.

1. Piston 2. Ring 3. Cylinder wall

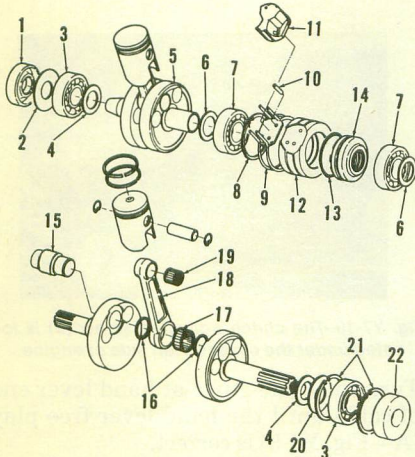

Fig. Y7-14—Exploded view of the crankshaft assembly.

- |                                   |                        |
|-----------------------------------|------------------------|
| 1. Oil seal                       | 12. Center housing     |
| 2. Bearing cover                  | 13. "O" ring           |
| 3. Main bearings                  | 14. Center seal        |
| 4. Shims                          | 15. Crankpin           |
| 5. Crankshaft right cylinder half | 16. Crankpin washers   |
| 6. Shims                          | 17. Crankpin bearing   |
| 7. Center main bearings           | 18. Connecting rod     |
| 8. Snap ring                      | 19. Piston pin bearing |
| 9. Gasket                         | 20. Shim               |
| 10. Pin                           | 21. Snap ring          |
| 11. Filler piece                  | 22. Oil seal           |

**REPAIRS**

**PISTONS, RINGS AND CYLINDERS.** Each piston can be removed after removing exhaust pipe, carburetor, cylinder head and cylinder. Refer to the following specifications:

Ring end gap—  
YDS-5 & YM2C

Top ring ..... 0.15-0.30MM  
(0.006-0.012 in.)

Second ring ..... 0.1-0.2MM  
(0.004-0.008 in.)

DS6—both rings ..... 0.15-0.35MM  
(0.006-0.014 in.)

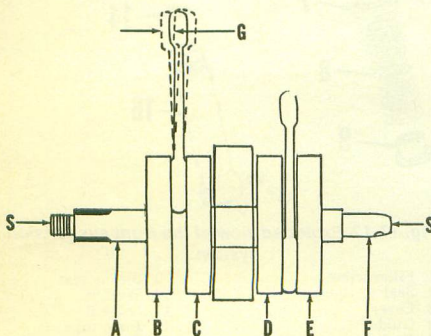

Fig. Y7-15—Refer to text for checking crankshaft for correct assembly or wear.

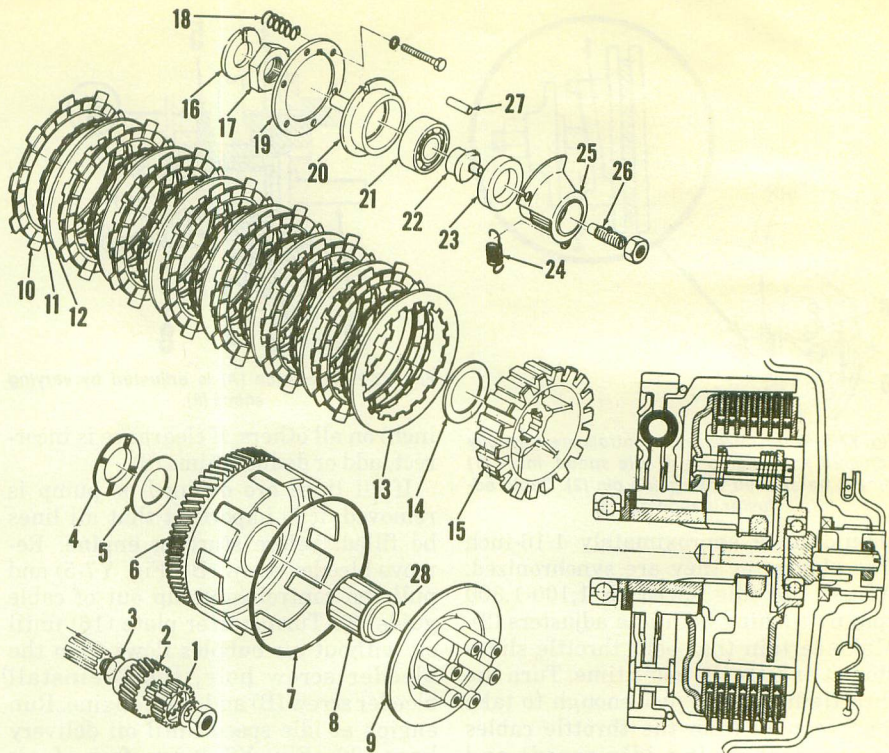

Fig. Y7-16—Exploded view of the clutch assembly. Inset shows cross section of clutch.

- |                                  |                                 |                            |                             |
|----------------------------------|---------------------------------|----------------------------|-----------------------------|
| 1. Oil pump gear                 | 8. Bearing                      | 14. Thrust washer          | 21. Release bearing         |
| 2. Crankshaft primary drive gear | 9. Pressure plate               | 15. Clutch hub             | 22. Release plug            |
| 3. "O" ring                      | 10. Friction discs (7 used)     | 16. Lock washer            | 23. Oil seal                |
| 4. Thrust plate                  | 11. Separator rings (7 used)    | 17. Hub nut                | 24. Return spring           |
| 5. Thrust washer                 | 12. Clutch plates (6 used)      | 18. Clutch spring (6 used) | 25. Release lever and screw |
| 6. Clutch drum                   | 13. Thick clutch plate (1 used) | 19. Spring plate           | 26. Adjusting screw         |
| 7. "O" ring                      |                                 | 20. Push crown             | 27. Pin                     |
|                                  |                                 |                            | 28. Bearing sleeve          |

**Standard cylinder bore diameter**

YDS-5 ..... 56MM (2.20 inch)

YM-2C ..... 60MM (2.36 inch)

DS6 ..... 56MM (2.20 inch)

**Maximum cylinder bore taper**

or out of round ..... 0.05MM  
(0.002 in.)

**Piston skirt to cylinder**

clearance ..... 0.035-0.040MM  
(0.0014-0.0016 in.)

Piston skirt clearance in cylinder bore should be measured by first measuring piston diameter at right angles to piston pin and cylinder bore diameter, then subtracting. The piston

should be measured 10MM (0.4 inch) above bottom edge of skirt. Make sure that rings correctly engage pins in the ring grooves and marks on side of rings are toward top of piston. Pistons should be installed on connecting rods with arrow pointing toward front. Cylinder head stud nuts should be torqued to 180 inch-pounds.

DS6 models are equipped with Keystone type pistons and rings. (Fig. Y7-13). A standard type piston will not accept Keystone rings and a Keystone type piston will not accept standard type rings. However, a Keystone type

Fig. Y7-19—Exploded view of transmission. Refer also to Fig. Y7-20.

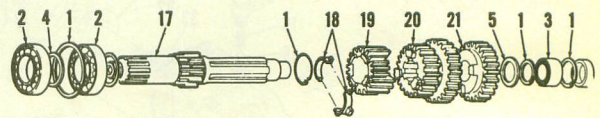

- |                        |
|------------------------|
| 1. Snap rings          |
| 2. Ball bearings       |
| 3. Needle bearing      |
| 4. Spacer              |
| 5. Washer              |
| 6. Shim                |
| 7. Thrust washer       |
| 8. Kick starter pinion |
| 9. Spacer              |
| 10. Washers            |
| 11. Washers            |
| 12. Setting plate      |
| 13. Shim               |
| 14. Oil seal           |
| 15. Collar             |
| 17. Input shaft        |
| 18. Setting plate      |
| 19. Second gear        |
| 20. Third & fifth gear |
| 21. Fourth gear        |
| 22. Oil catcher        |
| 23. First gear         |
| 24. Second gear        |

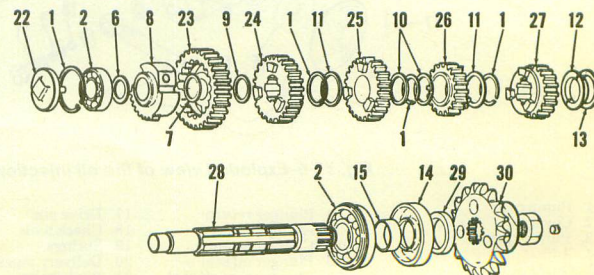

- |                |                  |                     |
|----------------|------------------|---------------------|
| 25. Third gear | 27. Fourth gear  | 29. Spacer          |
| 26. Fifth gear | 28. Output shaft | 30. Output sprocket |



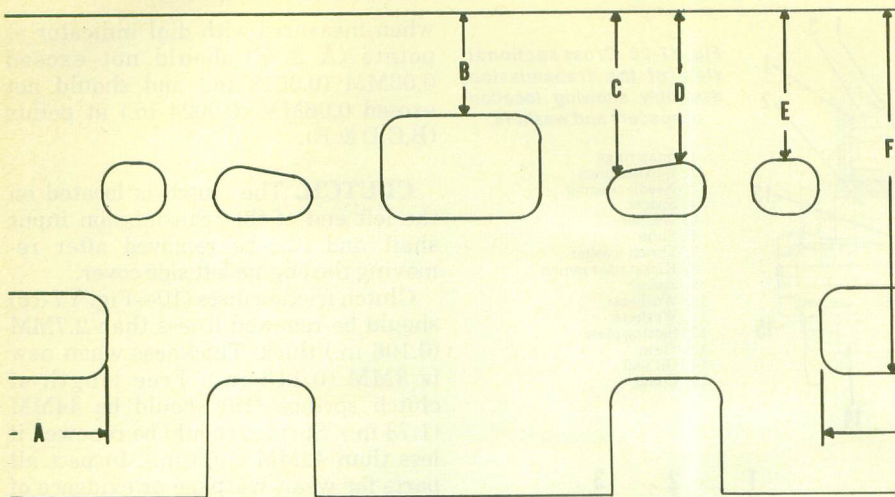

Fig. YT7-1—Cylinder porting of TD-2 road racer may be incorporated into standard DS-6 cylinder. Do not leave any sharp edges protruding into cylinder.

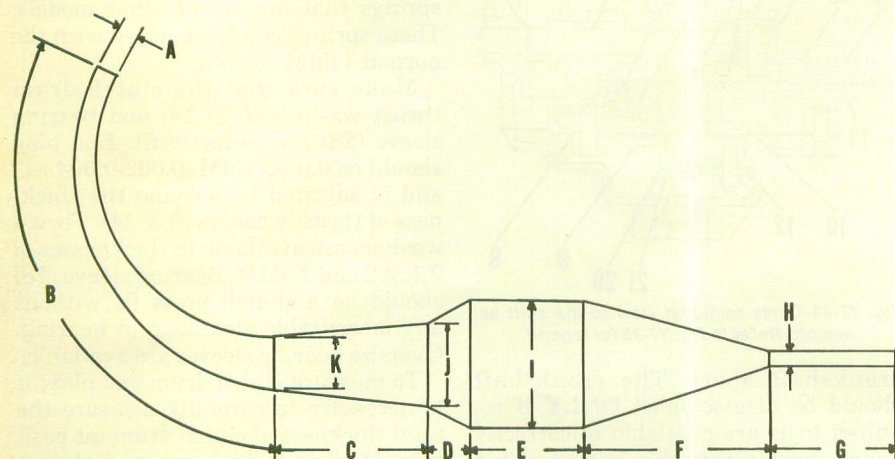

Fig. YT7-2—Basic design of Yamaha TD-2 road racer expansion chamber. Chamber will improve the performance of a correctly modified DS-6 street twin.

washers. Subtract the total thickness from the length of the bearing sleeve (28). If the difference (end play) is not within the limits of 0.05-0.10MM (0.002-0.004 in.), it is necessary to install thrust washers (5 & 14) of different thickness. The clutch will not release properly if end play is too tight. On some DS6 models thrust washers (5 & 14) are made of fiber and should be renewed if they appear worn.

Use grease to hold the thrust washers (5 & 14) in position around the

bearing sleeve when installing the drum (6), sleeve (28) and thrust washers (5 & 14). Be careful not to twist separator rings (11) when assembling.

**CRANKCASE AND GEAR BOX.**

The kickstarter gear should be installed on shaft with mark on gear aligned with spring hooking hole as shown in Fig. Y7-21. Shifter stop bolts (S—Fig. Y7-22) should have approximately 1MM (0.04 in.) clearance as the stop ball falls into detent in the cam.

**SPEED TUNING**

Model YDS-5 is the basis for the TD1-C series production road racers. Features of the TD1-C may be incorporated in YDS-5 models to improve performance.

The TD-2 road racer is based on the DS-6 250cc street twin. The TD-2 specifications in the following paragraphs may be used as a guide in speed tuning the DS-6 models. Any modification of standard parts or installation of performance parts will void manufacturer's warranty.

**CARBURETORS.** The TD-2 is equipped with 30MM sliding valve Mikuni units.

**PISTON, CYLINDER AND HEAD.** Standard DS-6 cylinder head may be milled to a capacity of 11.3cc. Be sure to remachine the taper in edge of combustion chamber.

A TD-2 piston measures 54MM (2.126 in.) long while a standard DS-6 piston is 63MM (2.480 in.) long. Metal may be removed from the skirt of the DS-6 piston to meet TD-2 specifications.

The following cylinder porting specifications may be incorporated into a standard DS-6 cylinder. (Refer to Fig. YT7-1)

- A. 34MM (1.388 in.)
- B. 25MM (0.984 in.)
- C. 39.5MM (1.55 in.)
- D. 37.5MM (1.47 in.)
- E. 37.5MM (1.47 in.)
- F. 87MM (3.4252 in.)

**EXPANSION CHAMBER.** An expansion chamber designed for the TD-2 Daytona road racer will work well on a modified DS-6.

The following specifications were taken from a TD-2 road racer chamber. (See Fig. YT7-2).

- A. 42MM (1.653 in.)
- B. 266MM (10.472 in.)
- C. 190MM (7.48 in.)
- D. 45MM (1.77 in.)
- E. 160MM (6.299 in.)
- F. 175MM (6.889 in.)
- G. 175MM (6.889 in.)
- H. 20MM (0.787 in.)
- I. 97MM (3.818 in.)
- J. 80MM (3.149 in.)
- K. 54MM (2.126 in.)

# YAMAHA YR-1, YR-2, AND R-3 350CC TWIN CYLINDER MODELS

	<b>YR-1, YR-2</b>
<b>MODEL</b>	<b>YR-2C, R-3, R-3C</b>
Displacement—cc	348
Bore—MM	61
Stroke—MM	59.6
Number of cylinders	2
Engine Lubrication	Oil Injection
Spark plug—	
Type	NGK B9HC
Electrode gap—MM	0.5-0.6
Inch	0.020-0.024
Ignition—	
Point gap—MM	0.30-0.35
Inch	0.012-0.014
Timing—MM BTDC	2.1
Electrical system voltage	12
Battery terminal grounded	Neg
Tire size—Front	3.00-18
Rear	*3.50-18
Tire pressure—	
Front—kg/cm <sup>2</sup>	1.5
Psi	22
Rear—kg/cm <sup>2</sup>	2.0
Psi	†28
Rear chain free play—MM	16-20
Inch	5/8-3/4
Rear chain size	530
Number of speeds	5
*Tire size is 3.25-18 on YR-1 models.	
†Tire pressure is 25 psi on R-3 models.	
Illustrations courtesy Yamaha International Corporation.	

### MAINTENANCE

**SPARK PLUGS.** Recommended spark plug electrode gap is 0.5-0.6MM (0.020-0.024 in.). Suggested spark plug for normal use is NGK type B9HC. Champion L-5 or L-81 can be used.

**CARBURETORS.** Two Mikuni VM carburetors are used. Idle speed should be set at approximately 1,200 rpm by turning adjusters (2—Fig. Y8-1). Make

sure that throttle slides (7) both stop at exactly the same position and exhaust pressure is the same for both cylinders. Idle mixture is changed by turning needles (11). Initial setting is 1½ turns open. Turning the needle counter-clockwise leans the mixture. Carburetors must be synchronized to open exactly the same amount by turning cable guides (1) on top of each carburetor. To synchronize, begin by turning idle speed adjusters (2) all the way down, then adjust cable guides (1) to begin raising throttle slides at the same time. After carburetors are correctly synchronized, adjust idle speed. Throttle cables must not have any slack (free play) at carburetors, but cable at hand grip should have approximately 1/16-inch free play. Oil pump control cable should be adjusted after throttle cables are adjusted.

Float level (H—Fig. Y8-2) should be 25.4MM (1 in.) and is adjusted by bending tang (17) on float. Refer to Fig. Y8-1 and the following standard specifications:

- Main jet (9) ..... #160 or 170
- Pilot jet (14) ..... #30
- Needle jet (13) ..... 0-2
- Valve needle (6) ..... 5D1
- Clip (5) in second or third groove from top of needle (6).

**IGNITION AND ELECTRICAL.** All models are equipped with a battery ignition system with an individual set of breaker points, condenser and coil for each cylinder. The generator is mounted at the left end of the crankshaft and the breaker points are mounted on the generator stator.

Breaker point gap at maximum opening should be 0.30-0.35MM (0.012-

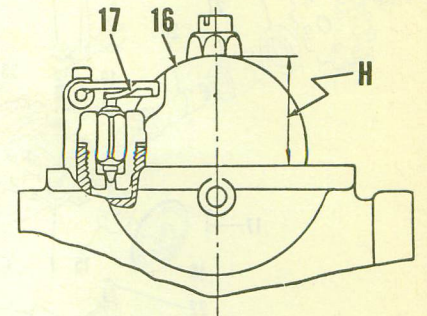

Fig. Y8-2—Float level (H) is adjusted by bending tang (17).

0.014 in.). The breaker points should just open when the piston is 2.1MM (0.083 in.) BTDC. Make sure that ignition advance weights are fully extended (out) when checking the timing. Ignition timing must be checked and adjusted individually for each cylinder. A static timing light or meter can be used to indicate point opening and a dial indicator in the spark plug hole to position the piston. Timing is changed by moving the breaker point assembly in the elongated holes after loosening the two mounting screws.

**LUBRICATION.** The engine is lubricated by oil contained in a separate tank. A pump and metering unit pumps oil from the tank to each cylinder inlet passage. The oil tank should never be allowed to run dry. SAE 30 two-stroke oil should be used. The oil pump control cable should be accurately adjusted to provide the correct amount of oil. If the cable adjustment is incorrect, the engine may be damaged.

Before adjusting the pump control cable, it is important that the throttle

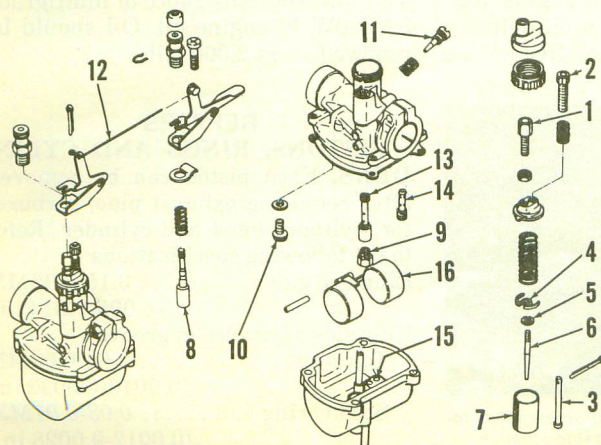

Fig. Y8-1—Exploded view of Mikuni VM carburetor. Starting valves for both carburetors are connected with rod (12).

- 1. Throttle cable guide
- 2. Idle speed adjuster
- 3. Idle speed rod
- 4. Retainer
- 5. Clip
- 6. Valve needle
- 7. Throttle slide
- 8. Starting valve
- 9. Main jet
- 10. Fuel inlet valve
- 11. Idle mixture needle
- 12. Link rod
- 13. Needle jet
- 14. Pilot jet
- 15. Starting jet
- 16. Float

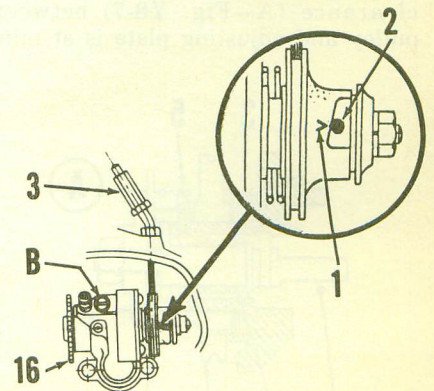

Fig. Y8-5—When carburetor controls are correctly adjusted and engine is at idle speed, mark (1) should be aligned with guide pin (2). Cable adjuster is shown at (3).

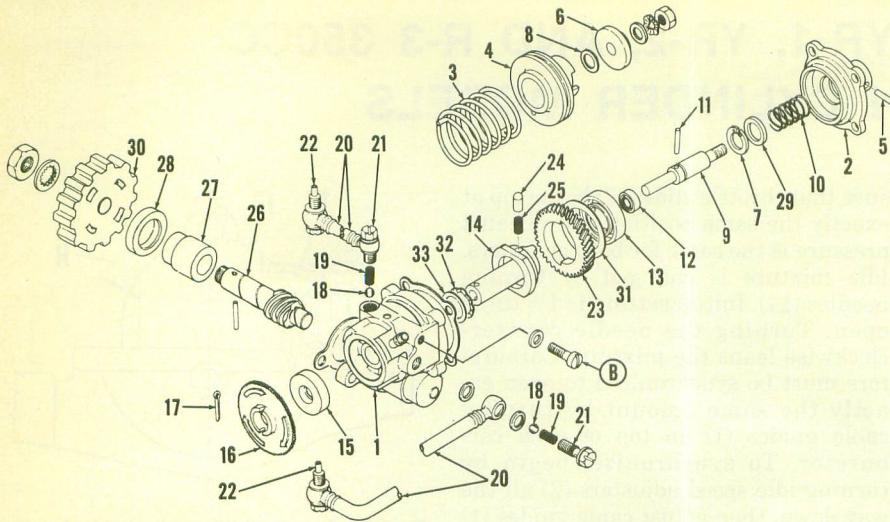

Fig. Y8-6—Exploded view of the oil injection pump unit.

- |                  |                           |                    |                      |
|------------------|---------------------------|--------------------|----------------------|
| 1. Pump case     | 10. Plunger return spring | 17. Drive pin      | 25. Spring           |
| 2. Cover         | 11. Cam guide pin         | 18. Check balls    | 26. Worm shaft       |
| 3. Pulley spring | 12. Plunger oil seal      | 19. Springs        | 27. Bushing          |
| 4. Adjust pulley | 13. Plunger cam oil seal  | 20. Delivery pipes | 28. Oil seal         |
| 5. Guide pin     | 14. Distributor           | 21. Banjo bolts    | 29. Spring seat      |
| 6. Adjust plate  | 15. Oil seal              | 22. Injector bolt  | 30. Drive gear       |
| 7. Snap ring     | 16. Starter plate         | 23. Worm wheel     | 31. Worm wheel plate |
| 8. Shims         |                           | 24. Worm wheel pin | 32. Wave washer      |
| 9. Plunger       |                           |                    | 33. Plate            |

cable guides (1—Fig. Y8-1) are correctly set. To adjust the throttle cable guides, turn the idle speed adjusters (2) all the way down, then synchronize cable guides (1) so that both throttle slides (7), begin to move at exactly the same time when the hand grip is turned. The throttle cables should have approximately 1/16-inch free play after they are synchronized. Adjust the idle speed to 1,100-1,300 rpm by turning both idle adjusters (2). Make certain that both throttle slides stop at exactly the same time. Turn the throttle hand grip just enough to take up free play from the throttle cables (without changing idle speed) and check the oil pump setting mark and guide pin as shown in Fig. Y8-5. If the mark (1) is not exactly aligned with guide pin (2); loosen the lock nut and turn the pump cable adjuster (3) as required to align.

Check the minimum plunger stroke by turning starter plate (16) until clearance (A—Fig. Y8-7) between pulley and adjusting plate is at min-

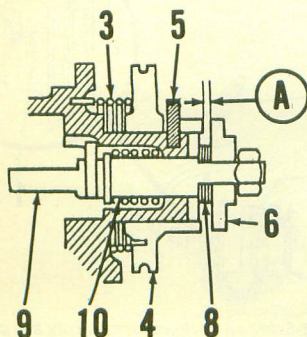

Fig. Y8-7—Clearance (A) is adjusted by varying shims (8).

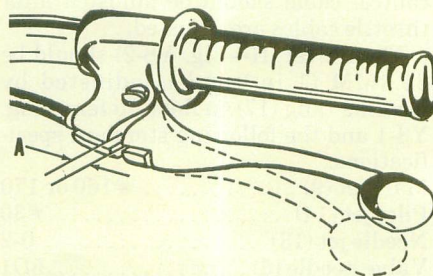

Fig. Y8-9—The clutch hand lever should have 2-3MM free play at (A).

imum. Clearance (A) should be 0.20-0.25MM (0.0079-0.0098 inch). If clearance is incorrect, add or deduct shims (8).

If oil lines are drained or pump is removed, it is important that all lines be filled before starting engine. Remove bleeder screw (B—Fig. Y8-5) and pull the control cable up out of cable guide (3). Turn starter plate (16) until oil without air bubbles flows from the bleeder screw hole, then reinstall bleeder screw (B) and start engine. Run engine at idle speed until oil delivery lines (20—Fig. Y8-6) are free of air bubbles.

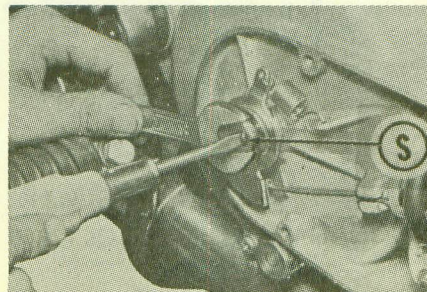

Fig. Y8-10—The clutch adjusting screw (S) is located under the cover on right side of engine.

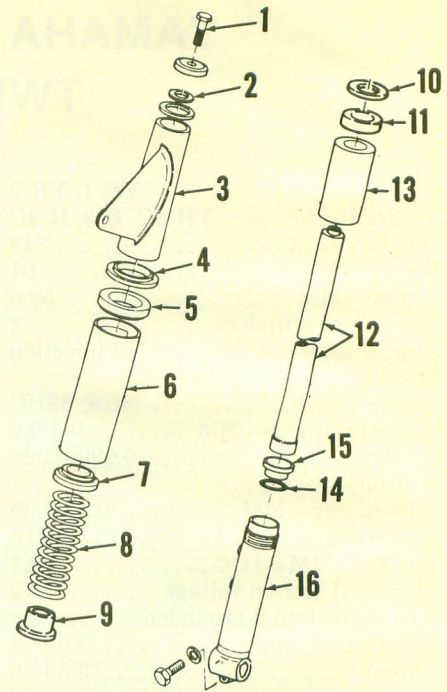

Fig. Y8-12—Exploded view of front suspension system used on YR-1 and YR-2 models.

- |                 |                |
|-----------------|----------------|
| 1. Filler screw | 9. Spring seat |
| 2. Seal         | 10. Washer     |
| 3. Cover        | 11. Oil seal   |
| 4. Guide        | 12. Inner tube |
| 5. Gasket       | 13. Tube nut   |
| 6. Cover        | 14. "O" ring   |
| 7. Spring seat  | 15. Bushing    |
| 8. Spring       | 16. Lower tube |

The gear box contains 1¼ quarts of SAE 10W/30 or 20W/40 motor oil and should be drained and refilled every 2000 miles.

**CLUTCH CONTROLS.** The clutch hand lever should have 1/16-½ inch free play at (A—Fig. Y8-9). To adjust, remove the cover from right side of engine and loosen lock nut. Turn the adjusting screw (S—Fig. Y8-10) in until slight resistance is felt, then back screw out ¼ turn and tighten lock nut. Turn the cable guide at hand lever end of cable until the hand lever free play (A—Fig. Y8-9) is correct.

**SUSPENSION.** Each front suspension unit contains 240cc of multigrade SAE20W/40 engine oil. Oil should be renewed every 2,000 miles.

**REPAIRS**

**PISTONS, RINGS AND CYLINDERS.** Each piston can be removed after removing exhaust pipe, carburetor, cylinder head and cylinder. Refer to the following specifications:

- |                                |                                    |
|--------------------------------|------------------------------------|
| Ring end gap                   | 0.15-0.35MM<br>(0.006-0.014 in.)   |
| Ring side clearance in groove— |                                    |
| Top ring                       | 0.04-0.08MM<br>(0.0016-0.0032 in.) |
| Second ring                    | 0.03-0.07MM<br>(0.0012-0.0028 in.) |

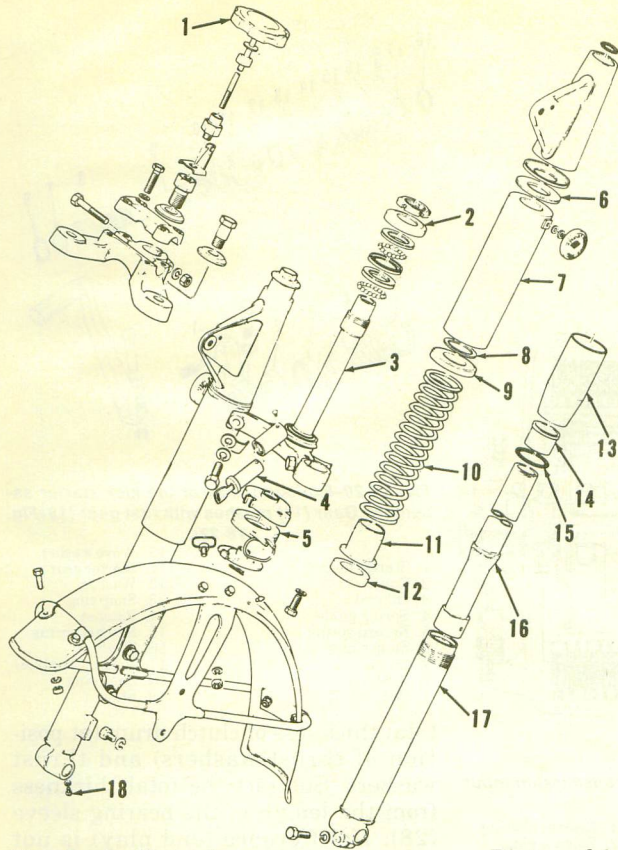

Fig. Y8-13—Exploded view of R3 steering and front suspension assembly.

1. Steering damper handle
2. Ball race cover
3. Steering stem assembly
4. Fork lock
5. Damper friction plates
6. Packing
7. Cover
8. Upper spring washer
9. Upper spring seat
10. Fork spring
11. Lower spring seat
12. Oil seal
13. Outer tube nut
14. Metal slider
15. "O" ring
16. Inner tube
17. Outer tube
18. Oil drain plug

Standard cylinder bore diameter . . . . . 61MM (2.4 inches)  
 Maximum cylinder bore taper or out of round . . . . . 0.05MM (0.002 in.)  
 Piston skirt to cylinder clearance . . . . . 0.030-0.035MM (0.0012-0.0014 in.)

Piston skirt clearance in cylinder bore should be measured by first measuring piston diameter at right angles to piston pin and cylinder bore diameter, then subtracting. The piston should be measured 10MM (0.4 inch) above bottom edge of skirt. Make sure that rings correctly engage pins in the ring grooves and marks on side of rings are toward top of piston. Pistons should be installed on connecting rods with arrow pointing toward front. Cylinder head stud nuts should be torqued to 180 inch-pounds.

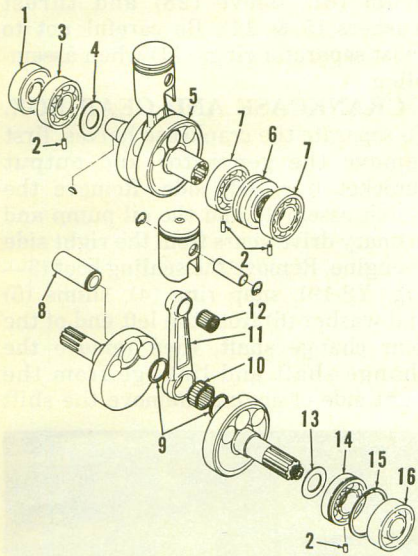

Fig. Y8-14—Exploded view of the crankshaft assembly.

- |                                  |                        |
|----------------------------------|------------------------|
| 1. Oil seal                      | 9. Crankpin washers    |
| 2. Dowel pins                    | 10. Crankpin bearing   |
| 3. Left main bearing             | 11. Connecting rod     |
| 4. Shims                         | 12. Piston pin bearing |
| 5. Crankshaft left cylinder half | 13. Shim               |
| 6. Center seal                   | 14. Right main bearing |
| 7. Center main bearings          | 15. Snap ring          |
| 8. Crankpin                      | 16. Oil seal           |

**CONNECTING RODS AND CRANKSHAFT.** The crankcase halves must be separated to remove the crankshaft. Refer to Fig. Y8-21. Connecting rods, crankpins rod bearings and the center main bearings and seal are removed by pressing the crankshaft apart. The crankshaft should be disassembled **ONLY** if required tools are available to correctly check and align the reassembled crankshaft. If side shake (G—Fig. Y8-15) at piston pin end of connecting rod exceeds 2MM (0.08 in.), the connecting rod, crankpin and lower bearing should be renewed. Shake (G) should be 0.8-1.0MM (0.032-0.039 in.). Side clearance of connecting rod between the crankshaft counter weights can be measured with a feeler gage. Side clearance should be 0.1-0.3MM (0.0039-0.012 in.). With crankshaft supported between lathe centers (S—Fig. Y8-15), maximum eccentricity

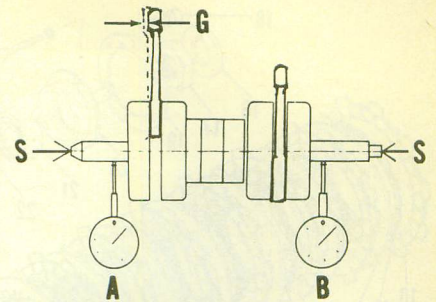

Fig. Y8-15—Refer to text for checking crankshaft for correct assembly or wear.

when measured with a dial indicator at points (A & B) should not exceed 0.015MM (0.0006 in.).

When reinstalling crankshaft, make certain that the holes in all four main bearing outer races correctly engage the locating dowels (D—Fig. Y8-16) in the top crankcase half. Snap ring on right main bearing outer race should be installed so that open space between ends of snap ring is aligned with the oil groove (G) in the top crankcase half. The oil seal on left end of crankshaft should be installed flush with the crankcase surface. The oil seal on the right end of crankshaft should be installed so that edge of seal contacts the outer race of main bearing. Yamaha bond No. 5 or equivalent sealer should be applied evenly to the complete mating surfaces of crankcase halves. Install the lower half making sure that screws are torqued in the sequence stamped on lower half. The 6MM screws should be tightened to 87 inch-pounds torque and the 8MM screws should be torqued to 174 inch-pounds.

**CLUTCH.** The clutch is located on the right end of the transmission input shaft and can be removed after removing the engine right side cover.

Clutch friction discs (10—Fig. Y8-17) should be renewed if less than 2.7MM (0.106 in.) thick. Thickness when new is 3MM (0.118 in.). Free length of

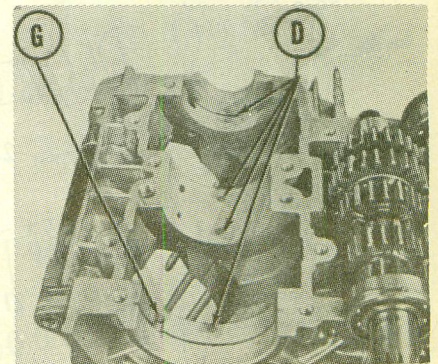

Fig. Y8-16—When installing crankshaft, make certain that dowels (D) engage holes in all four main bearing outer races. Align open space of snap ring (15—Fig. Y8-14) with oil groove (G).

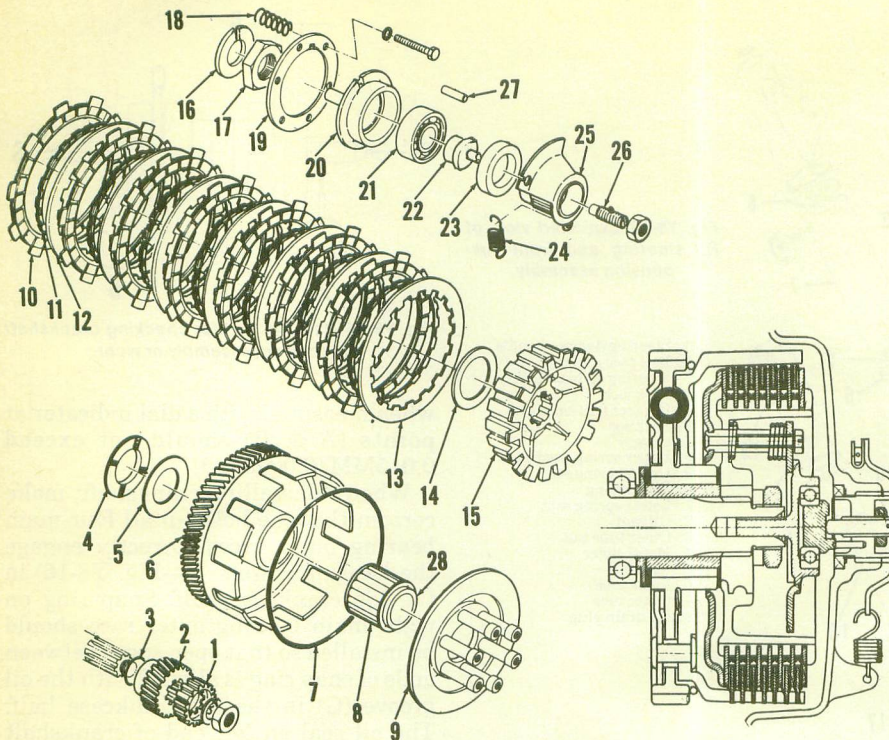

Fig. Y8-17—Exploded view of the clutch assembly. Unit is mounted on right end of transmission input shaft and is driven by the crankshaft primary drive gear (2).

- |                                  |                                 |                             |
|----------------------------------|---------------------------------|-----------------------------|
| 1. Oil pump gear                 | 8. Bearing                      | 14. Thrust washer           |
| 2. Crankshaft primary drive gear | 9. Pressure plate               | 15. Clutch hub              |
| 3. "O" ring                      | 10. Friction discs (7 used)     | 16. Lock washer             |
| 4. Thrust plate                  | 11. Separator rings (7 used)    | 17. Hub nut                 |
| 5. Thrust washer                 | 12. Clutch plates (6 used)      | 18. Clutch spring (6 used)  |
| 6. Clutch drum                   | 13. Thick clutch plate (1 used) | 19. Spring plate            |
| 7. "O" ring                      |                                 | 20. Push crown              |
|                                  |                                 | 21. Release bearing         |
|                                  |                                 | 22. Release plug            |
|                                  |                                 | 23. Oil seal                |
|                                  |                                 | 24. Return spring           |
|                                  |                                 | 25. Release lever and screw |
|                                  |                                 | 26. Adjusting screw         |
|                                  |                                 | 27. Spring pin              |
|                                  |                                 | 28. Bearing sleeve          |

clutch springs (18) should be 36.4MM (1.43 in.). Springs should be renewed if less than 35.4MM (1.39 in.). Inspect all parts for wear, warpage or evidence of overheating.

Make sure that the clutch drum thrust washers (5 & 14) and bearing sleeve (28) are correctly fit. End play should be 0.05-0.1MM (0.002-0.004 in.)

and is adjusted by varying the thickness of thrust washers (5 & 14). Thrust washers are available in thicknesses of 2.1, 2.2 and 2.3MM. Bearing sleeve (28) should be a thumb press fit without any measurable clearance in bearing. Oversize bearing sleeves are available.

To measure clutch drum end play, it is necessary to carefully measure the

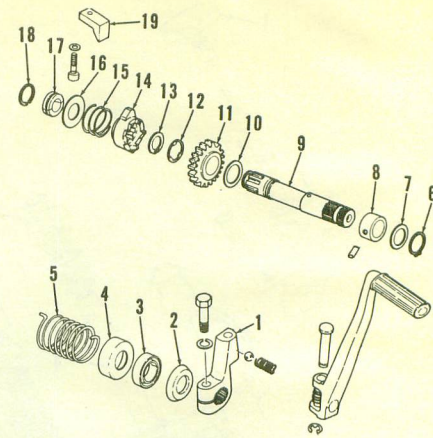

Fig. Y8-20—Exploded view of the kick starter assembly. Gear (11) meshes with first gear (19—Fig. Y8-22).

- |                  |                       |
|------------------|-----------------------|
| 1. Starter lever | 10. Wave washer       |
| 2. Cover         | 11. Starter gear      |
| 3. Oil seal      | 12. Washer            |
| 4. Spring guide  | 13. Snap ring         |
| 5. Return spring | 14. Ratchet           |
| 6. Snap ring     | 15. Ratchet spring    |
| 7. Shim          | 16. Washer            |
| 8. Bushing       | 17. Holder (2 halves) |
| 9. Pedal shaft   | 18. Snap ring         |
|                  | 19. Stop              |

total thickness of clutch drum (at position of thrust washers) and thrust washers. Subtract the total thickness from the length of the bearing sleeve (28). If difference (end play) is not within the limits of 0.05-0.1MM (0.002-0.004 in.), it is necessary to install thrust washers (5 & 14) of different thickness. The clutch will not release properly if end play is too tight.

Use grease to hold the thrust washers (5 & 14) in position around the bearing sleeve when installing the drum (6), sleeve (28) and thrust washers (5 & 14). Be careful not to twist separator rings (11) when assembling.

**CRANKCASE AND GEAR BOX.**

To separate the crankcase halves, first remove the generator and output sprocket from left side. Remove the clutch assembly and the oil pump and primary drive gears from the right side of engine. Remove the sealing boot (3—Fig. Y8-19), snap ring (4), shims (5) and washer (6) from the left end of the gear change shaft, then remove the change shaft and linkage from the right side of engine. Remove the shift

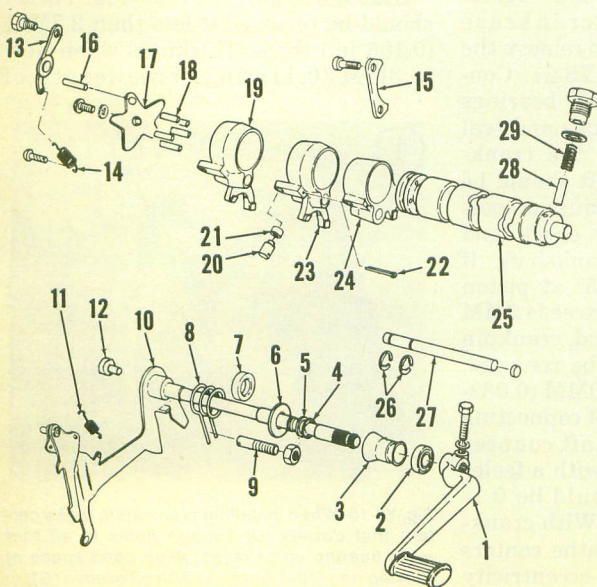

Fig. Y8-19—Exploded view of the gear shift assembly. Shift fork (19) moves gear (27—Fig. Y8-22), fork (23) moves gear (8—Fig. Y8-22) and fork (24) moves gear (20—Fig. Y8-22).

- |                               |
|-------------------------------|
| 1. Shift pedal                |
| 2. Seal                       |
| 3. Sealing boot               |
| 4. Snap ring                  |
| 5. Shims                      |
| 6. Washer                     |
| 7. Oil seal                   |
| 8. Return spring              |
| 9. Eccentric screw            |
| 10. Change shaft              |
| 11. Ratchet spring            |
| 12. Plug                      |
| 13. Detent                    |
| 14. Detent spring             |
| 15. Shift drum retainer plate |
| 16. Change pin (long)         |
| 17. Side plate                |
| 18. Change pins               |
| 19. Shift fork (5th)          |
| 20. Guide pin (3 used)        |
| 21. Roller (3 used)           |
| 22. Cotter pin (3 used)       |
| 23. Shift fork (2nd & 4th)    |
| 24. Shift fork (1st & 3rd)    |
| 25. Shift drum                |
| 26. Snap rings                |
| 27. Shift fork rail           |
| 28. Neutral detent            |
| 29. Detent spring             |

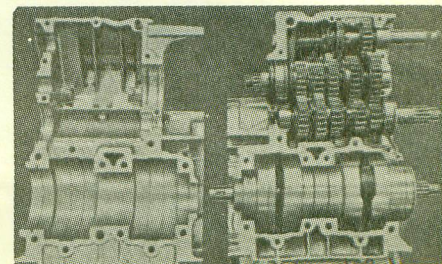

Fig. Y8-21—Gears and shafts should stay in place in the top half of crankcase when the lower half is lifted off.

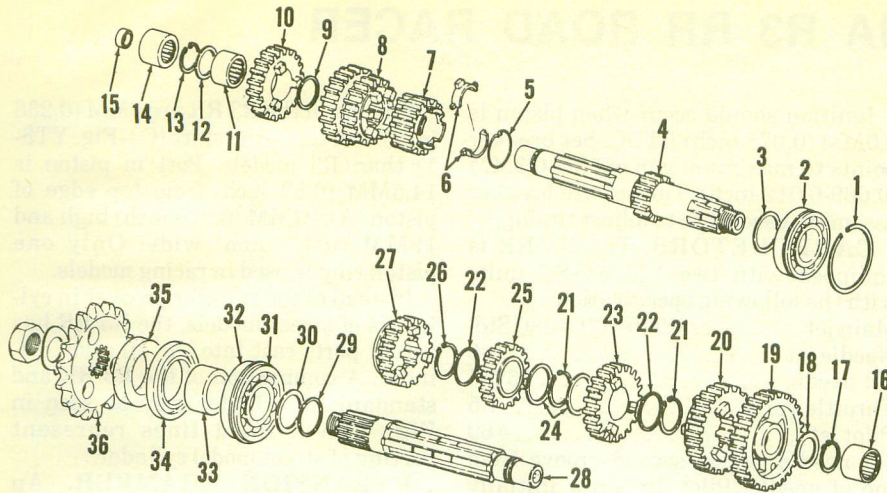

Fig. Y8-22—Exploded view of the transmission assembly. Refer to Fig. Y8-21 for view of parts installed in the top half of crankcase.

- |                               |                   |                        |                        |
|-------------------------------|-------------------|------------------------|------------------------|
| 1. Snap ring                  | 9. Washer         | 18. Washer             | 27. Sliding gear (4th) |
| 2. Bearing                    | 10. Fourth gear   | 19. First gear         | 28. Output shaft       |
| 3. Shim                       | 11. Gear bearing  | 20. Sliding gear (2nd) | 29. Shim               |
| 4. Input shaft and first gear | 12. Washer        | 21. Snap rings         | 30. Shim               |
| 5. Clip                       | 13. Snap ring     | 22. Washer             | 31. Snap ring          |
| 6. Gear setting plate         | 14. Shaft bearing | 23. Third gear         | 32. Bearing            |
| 7. Second gear                | 15. Plug          | 24. Washer             | 33. Collar             |
| 8. Sliding gear (3rd & 5th)   | 16. Bearing       | 25. Fifth gear         | 34. Oil seal           |
|                               | 17. Snap ring     | 26. Snap ring          | 35. Felt dust seal     |
|                               |                   |                        | 36. Output sprocket    |

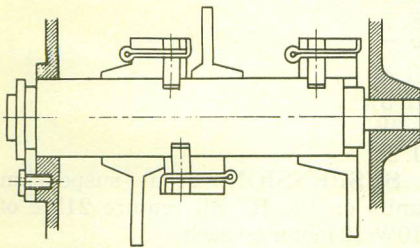

Fig. Y8-23—When installing the shift drum and forks, install cotter pins through guide pins in direction shown. Be sure that forks do not touch cotter pins.

detent (13) and retainer plate (15). Remove kick starter spring guide (4—Fig. Y8-20) and return spring (5). Turn the crankcase assembly upside down, remove the attaching screws and carefully separate the crankcase halves.

The gears and shafts should remain in place in the top half as shown in Fig. Y8-21.

When assembling, make sure that cotter pins for the guide pins are installed in direction shown in Fig. Y8-23 and do not touch shift forks. Marks on end of kick starter ratchet and pedal shaft should be aligned as shown in Fig. Y8-24. Install the crankcase lower half making sure that screws are tightened in sequence stamped on lower half. The 6MM screws should be tightened to 87 inch-pounds torque and the 8MM screws should be torqued to 174 inch-pounds. Adjust position of eccentric screw (S—Fig. Y8-25) until clearance (C) between shift ratchet and shift drum pins is the same.

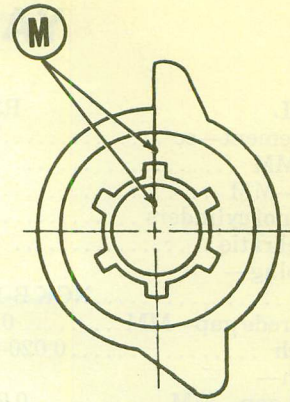

Fig. Y8-24—Align marks (M) on ratchet (14—Fig. Y8-20) and shaft (9) when assembling.

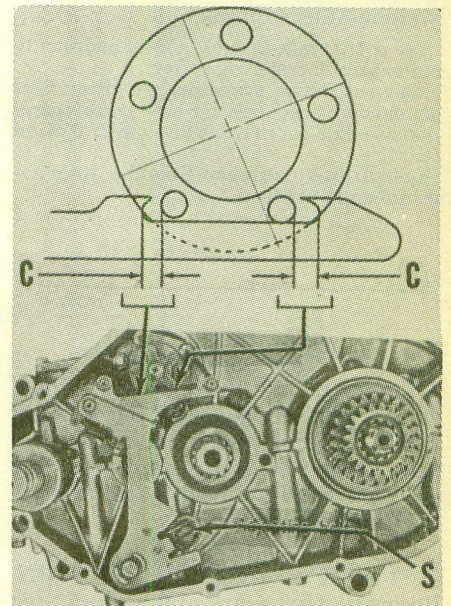

Fig. Y8-25—Turn the eccentric screw (S) until clearance (C) is the same on each side of shift drum pins.

# YAMAHA R3 RR ROAD RACER

<b>MODEL</b>	<b>R3 RR</b>
Displacement—cc .....	348
Bore—MM .....	61
Stroke—MM .....	59.6
Number of cylinders .....	2
Oil-Fuel ratio .....	1:20*
Spark plug—	
Type .....	NGK B-10EN
Electrode gap—MM .....	0.5-0.6
Inch .....	0.020-0.024
Ignition—	
Point gap—MM .....	0.23-0.3
Inch .....	0.009-0.012
Timing—MM BTDC .....	2.0
Tire pressure—Front .....	25.6 PSI**
Rear .....	28.5 PSI**
Number of speeds .....	5
Weight—Lbs. (approx.) .....	253

\*Use a 1:20 mix in fuel tank in addition to automatic oil metering system.

\*\*Dry track tire pressures are given. Recommended pressures for wet track operation are 24.2 psi in front tire and 27.0 psi in rear tire.

Illustrations courtesy Yamaha International Corporation.

## MAINTENANCE

The R3 RR is a factory prepared road racing version of the R3 series street twins. General repair and adjustment procedures for the R3 apply to R3 RR models except for the details in the following paragraphs.

### SPARK PLUG AND IGNITION.

Recommended spark plug for extended high speed operation is NGK type B-10EN or equivalent. An NGK type B-7E or B-8EN should be used to warm engine up.

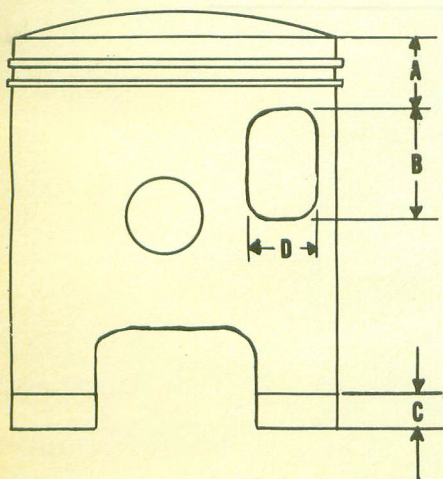

Fig. YT8-1—Drawing of standard R3 piston showing locations of comparison with road racing R3 RR piston.

Ignition should occur when piston is 2.0MM (0.078 inch) BTDC. Set breaker points to maximum gap of 0.23-0.3MM (0.009-0.012 inch). Turn entire breaker assembly base plate to adjust timing.

**CARBURETORS.** The R3 RR is equipped with two VM 34 SC units with the following specifications:

Main jet .....	#320-400 #380 Std.
Needle jet .....	0-6
Jet needle .....	6 F 5
Throttle valve .....	1.5
Pilot jet .....	#60
Jet needle clip in second groove from top of needle. Pilot air screw initially set 1½ turns out from a lightly seated position.	

Carburetors should be carefully inspected to make certain that throttle slides are at equal heights in slide bores at full throttle position.

**LUBRICATION.** The automatic oil metering system is retained but it is not affected by throttle position. Pump is secured to the full stroke position and only engine rpm will vary the amount of oil pumped. In addition to oil injection, a 20:1, fuel to oil mixture should be used in the fuel tank. A gasoline with an octane rating of 100 or better is recommended. Although not recommended, if oil pump is removed, a 12:1 fuel to oil mixture should be used in fuel tank.

**PISTON, CYLINDER AND CYLINDER HEAD.** A standard R3 RR cylinder head has a capacity of 16.3cc.

Pistons in the R3 RR are 6MM (0.236 inch) shorter in the skirt (C—Fig. YT8-1) than R3 models. Port in piston is 14.5MM (0.57 inch) from top edge of piston (A); 21MM (0.826 inch) high and 12MM (0.47 inch) wide. Only one piston ring is used in racing models.

Instead of the transfer grooves in cylinders of street models, the R3 RR has actual ports cast into the all alloy cylinder. A comparison of the R3 RR and standard R3 cylinder may be seen in Fig. YT8-2. Solid lines represent porting of street model cylinder.

**EXPANSION CHAMBER.** An expansion chamber similar to the one used on R3 RR models may be constructed with the following specifications (Fig. YT8-3): (All dimensions in inches)

- A. 11
- B. 8
- C. 2
- D. 6¼
- E. 7
- F. 7
- G. ¾
- H. 3¾
- I. 3¾
- J. 2¼

**SUSPENSION.** Front suspension units on the R3 RR require 215cc of 10W/30 motor oil each.

**CLUTCH.** Standard free length of clutch springs is 44MM (1.732 inch) on R3 RR models. Renew springs if less than 43MM (1.692 inch) long.

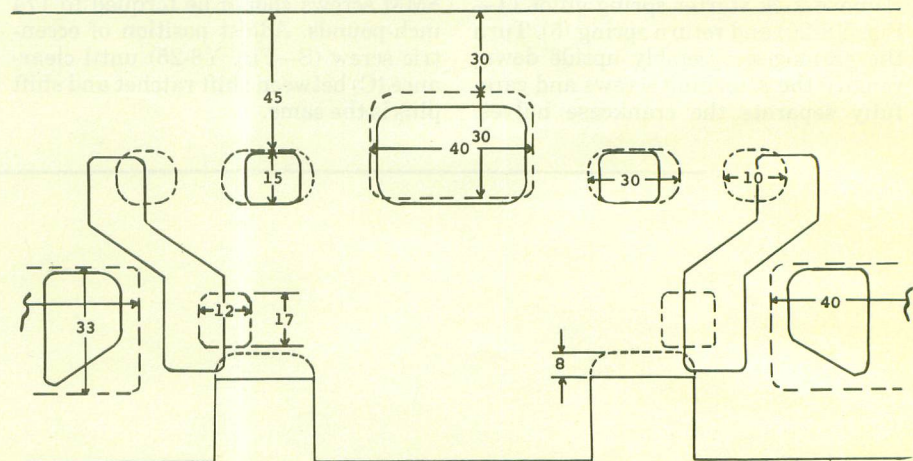
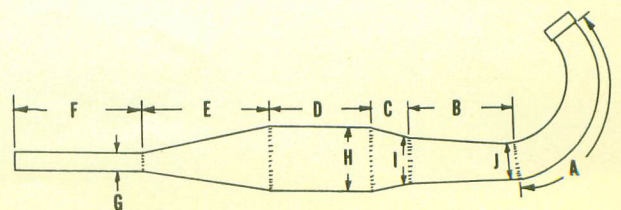

Fig. YT8-2—Comparison of R3 and R3 RR cylinder porting. All dimensions are in MM.

Fig. YT8-3—Diagram of expansion chamber used on an R3 RR road racer. Refer to text for dimensions.



# YAMAHA MODELS DS-7, R5, RD250 AND RD350

MODEL	DS7	R5, R5B, R5C	RD250, RD250A	RD350, RD350A
Displacement—cc .....	247	347	247	347
Bore—MM .....	54	64	54	64
Stroke—MM .....	54	54	54	54
Number of cylinders .....	2	2	2	2
Engine lubrication .....	Oil Injection	Oil Injection	Oil Injection	Oil Injection
Spark plug—				
Type .....	NGK B-8HS	NGK B-8HS	NGK B-8HS	NGK B-8HS
Electrode gap—MM .....	0.6-0.7	0.6-0.7	0.6-0.7	0.6-0.7
Inch .....	0.024-0.028	0.024-0.028	0.024-0.028	0.024-0.028
Ignition—				
Point gap—MM .....	0.3-0.4	0.3-0.4	0.3-0.4	0.3-0.4
Inch .....	0.012-0.016	0.012-0.016	0.012-0.016	0.012-0.016
Timing—MM BTDC .....	2.0	2.0	2.0	2.0
Electrical system voltage .....	12	12	12	12
Battery terminal grounded .....	Neg.	Neg.	Neg.	Neg.
Tire size—Front .....	3.00-18	3.00-18	3.00-18	3.00-18
Rear .....	3.25-18	3.50-18	3.25-18	3.50-18
Tire pressure—				
Front—kg/cm <sup>2</sup> .....	1.6	1.6	1.6	1.6
Psi .....	22	22	22	22
Rear—kg/cm <sup>2</sup> .....	2.0	2.0	2.0	2.0
Psi .....	28	28	28	28
Rear chain free play—MM .....	20	20	20	20
Inch .....	¾	¾	¾	¾
Number of speeds .....	5	5	6	6
Weight (approx.)—kg .....	138	141	140	143
Pounds .....	304	311	309	315

Illustrations courtesy Yamaha International Corporation.

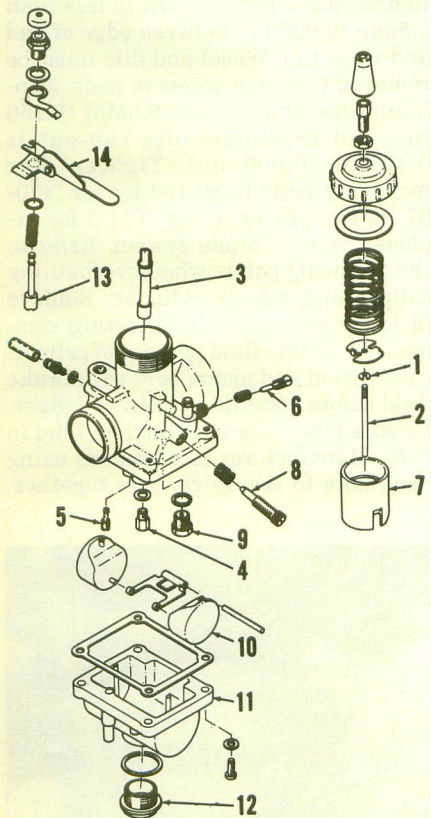

Fig. Y11-1—Exploded view of typical Mikuni carburetor used on all models.

- |                    |                           |
|--------------------|---------------------------|
| 1. Jet needle clip | 8. Throttle stop screw    |
| 2. Jet needle      | 9. Valve seat assembly    |
| 3. Needle jet      | 10. Float                 |
| 4. Main jet        | 11. Float bowl            |
| 5. Pilot jet       | 12. Float bowl drain plug |
| 6. Pilot air screw | 13. Starter plunger       |
| 7. Throttle slide  | 14. Starter lever         |

## MAINTENANCE

**SPARK PLUG.** Recommended spark plug is NGK type B-8HS with an electrode gap of 0.6-0.7MM (0.024-0.028 in.).

**CARBURETOR.** Model DS7 is equipped with two Mikuni VM26SC carburetors. Idle air screw setting is 1 turn open. All other models are equipped with two Mikuni VM28SC carburetors. Idle air screw setting is 1¼ turns open on models R5C and RD250A; 1½ turns open on model RD250; 1¾ turns open on models R5, R5B, RD350 RD350A. Float level for all models should be 15MM (A—Fig. Y11-2). Refer to following tables for carburetor specifications:

### Main jet

DS7 .....	#100
R5, R5B .....	#110
R5C, RD250, RD250A .....	#120
RD350, RD350A .....	#140

### Needle jet

RD250, RD250A, RD350,	
RD350A .....	0-8
All other models .....	0-0

### Jet needle

RD250 .....	5J6
RD250A, RD350, RD350A .....	5I4
All other models .....	5DP7

### Pilot jet

RD350, RD350A .....	#25
DS7, R5C, RD250, RD250A .....	#30
R5, R5B .....	#40

Jet needle clip should be in third groove from top of jet needle on models RD250, RD250A, RD350 and RD350A. Clip should be in fourth groove from top on all other models.

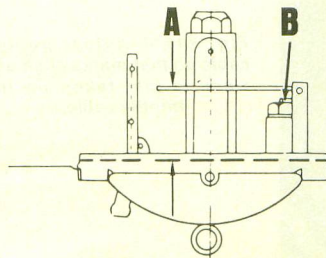

Fig. Y11-2—Float level (A) should be measured from gasket surface with gasket removed. Adjust level by bending tang (B).

## IGNITION AND ELECTRICAL. A

12 volt battery is located under the seat. The alternator is mounted at left end of crankshaft. A rectifier (also mounted beneath seat) is used to convert AC current to DC current for battery charging, lights and other electrical functions.

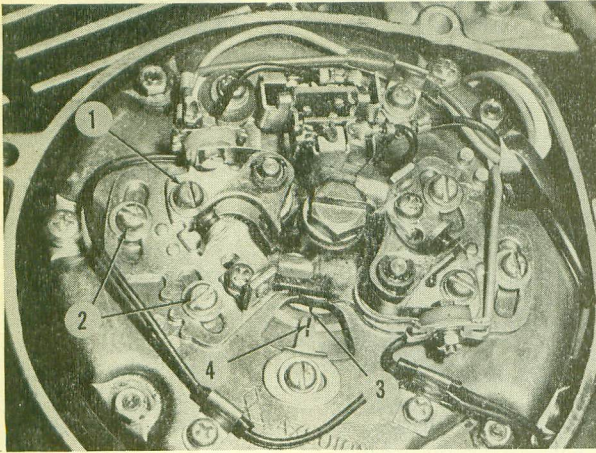

Fig. Y11-3—Engine should be timed with a dial gage to make certain that pointer (4) is in correct position before relying completely on pointer for timing.

Maximum point gap should be 0.3-0.4MM (0.012-0.016 inch) and can be adjusted after loosening screws (1—Fig. Y11-3). Ignition should occur (points just open) when piston is 2.0MM (0.078 in.) BTDC. Timing marks (3 & 4) should align at this point. Ignition timing should be checked separately for each cylinder. Loosening screws (2) will allow movement of breaker base plate and adjustment of timing for one cylinder. Orange wire is for left cylinder.

**LUBRICATION.** The gearbox contains 1.6 qt. of SAE 10W/30 motor oil. Lubricant should be drained and renewed every 1200 miles.

Engine lubrication is accomplished by an automatic oil metering system. Only oils intended for use in air cooled two cycle engines should be used. Adjust pump control cable so that mark on pulley (1—Fig. Y11-4) is lined up with pin (2) when engine is at idle (1300-1400 rpm).

Should pump be allowed to run dry or if it had been removed it will be nec-

essary to bleed the system. Remove bleeder bolt (3—Fig. Y11-4) and turn starter plate (4) in direction of arrow until pure oil (no air bubbles) is coming from bleeder hole. Holding throttle wide open will speed bleeding operation. Replace bleeder bolt and check for leaks with engine running.

**BRAKES.** Models RD350 and RD350A are equipped with a disc front brake and drum type rear brake while all other models are equipped with drum brakes at both wheels.

Hydraulic fluid on models RD350 and RD350A should be maintained at level shown in Fig. Y11-5. Only use brake fluid graded "DOT 3" or "DOT 4". Disc brake operation is adjusted by turning adjusting screw in brake lever. Normal adjustment provides 13-26MM ( $\frac{1}{2}$ -1 in.) free play at end of lever.

If air is present in hydraulic brake system, use the following procedure to bleed brake. Attach end of bleeder hose to bleeder valve (26—Fig. Y11-6) and submerge other end of hose in brake fluid to prevent air from re-entering

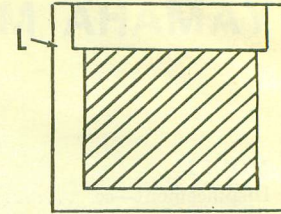

Fig. Y11-5—Hydraulic fluid level (L) in reservoir should be maintained at first step in reservoir body.

system. Keep reservoir on handlebar filled with brake fluid. Pull and hold brake lever in engaged position and loosen bleeder valve about  $\frac{1}{2}$  turn (until fluid flows from bleed hose). Tighten bleeder valve, then release brake lever. At first, air bubbles will be released from bleeder valve. Continue bleeding procedure until fluid released from bleeder valve is free of air bubbles. Do not release brake lever when bleeder valve is open; do not permit reservoir to run dry while bleeding. Brake fluid will remove paint so be careful when filling and bleeding fluid.

Each brake pad has an indicator tab which is painted red or has "INDICATOR" written on it. See Fig. Y11-5A. Renew brake pads if worn to less than 0.5mm (0.020 in.) between edge of pad and wear tab. Wheel and disc must be removed to obtain access to pads. Minimum disc thickness is 6.5MM (0.256 in.) and maximum disc run-out is 0.15MM (0.006 in.). Tighten disc mounting bolts to 80-100 kg.-cm. (70-87 in.-lbs.). Refer to Fig. Y11-6 for exploded view of brake system. Refer to the following points when overhauling caliper and master cylinder: Remove piston from caliper by directing compressed air into fluid passage of caliper. Coat piston and piston bore with brake fluid before installing piston in caliper. Be sure piston does not catch or bind in bore. Manufacturer recommends using new bolts to secure calipers together.

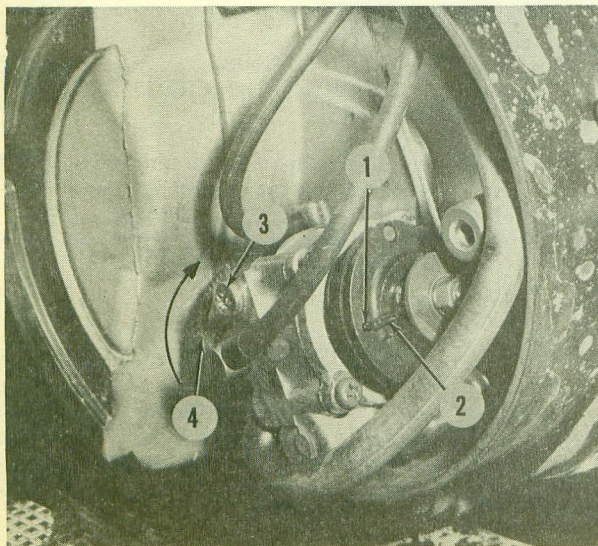

Fig. Y11-4—Adjust pump cable so that marks align as slack is just taken up in throttle cable.

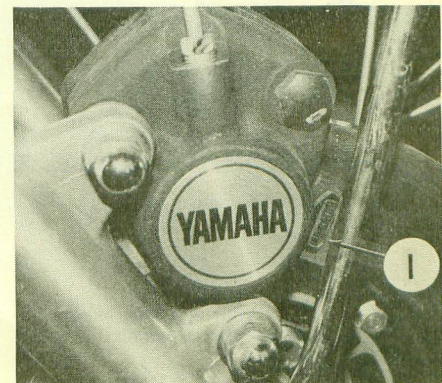

Fig. Y11-5A—Wear tab indicator (I) is used to determine when disc pad renewal is necessary. Wear tab on some models is painted red in place of "INDICATOR" shown above.

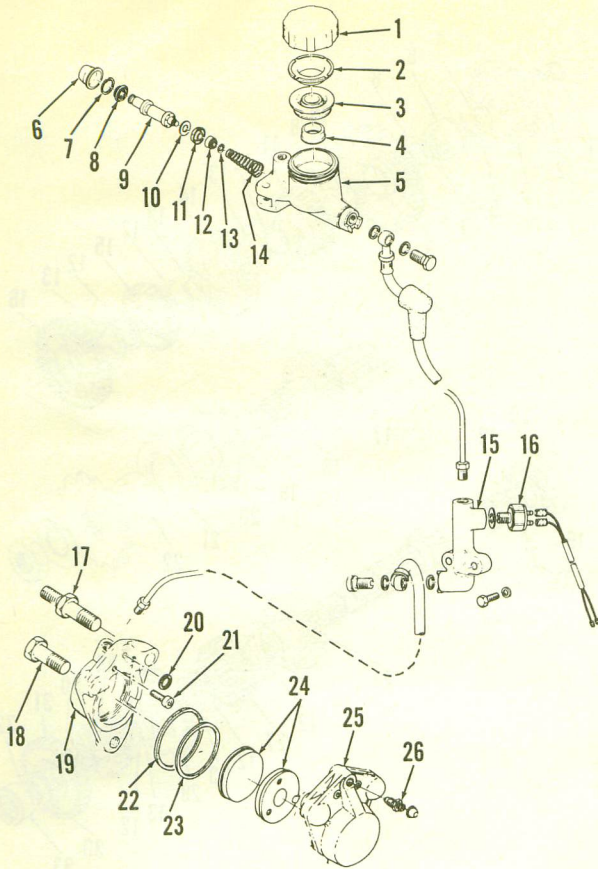

Fig. Y11-6—Exploded view of hydraulic brake system used on models RD350 and RD350A.

1. Reservoir cap
2. Diaphragm plate
3. Diaphragm
4. Diaphragm seat
5. Master cylinder & reservoir
6. Dust boot
7. Snap ring
8. Cup
9. Piston
10. Spacer
11. Cup retainer
12. "E" ring
13. Spring
14. Connector
15. Stop light switch
16. Caliper stud
17. Capscrew
18. Outer caliper half & piston
19. Seal
20. Piston seal
21. Dust seal
22. Disc pads
23. Inner caliper half & piston
24. Bleed valve

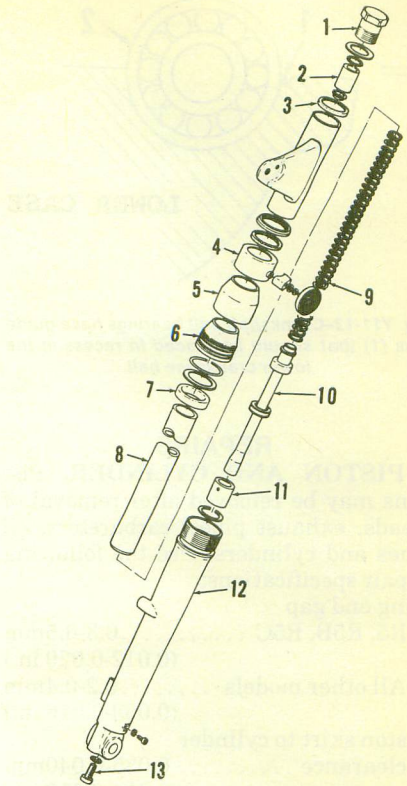

Fig. Y11-10—Exploded view of model DS7, R5, R5B and R5C front suspension unit.

- |                      |                         |
|----------------------|-------------------------|
| 1. Fork top bolt     | 8. Inner tube           |
| 2. Spacer            | 9. Fork spring          |
| 3. Upper cover guide | 10. Damper valve        |
| 4. Outer cover       | 11. Fork piston         |
| 5. Dust seal cover   | 12. Outer tube          |
| 6. Dust seal         | 13. Damper holding bolt |
| 7. Oil seal          |                         |

Tighten caliper bolts (17 and 18) to 750-950 kg.-cm. (54-69 in.-lbs.). Tighten caliper bolt and nut which retain caliper to fork leg to 400-500 kg.-cm. (29-36 ft.-lbs.). Install spacer (10) as shown in Fig. Y11-7. Install spring (14—Fig. Y11-6) with big end inserted first.

**CLUTCH CONTROLS.** To adjust clutch, remove the small cover on left side of engine case. Loosen lock nut (1—Fig. Y11-8) and turn screw (2) in until it seats lightly. Back screw out ¼ turn and tighten lock nut. The clutch lever should be adjusted to provide 1/16-1/8 inch free play. Refer to Fig. Y11-9.

**SUSPENSION.** Refer to Fig. Y11-10 or Fig. Y11-11 for an exploded view of front suspension. Oil capacity for each fork leg is 145cc for models DS7, R5, R5B and R5C, and 140cc for all

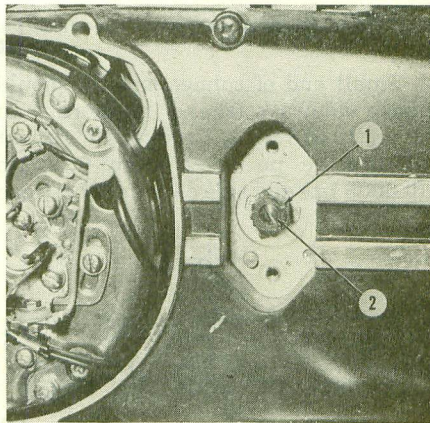

Fig. Y11-8—Clutch adjustment point on left side of engine.

other models. Recommended oil is SAE 10W/30. Fork leg may be disassembled after unscrewing lower bolt (13). Rear suspension cannot be repaired and must be serviced as a unit assembly.

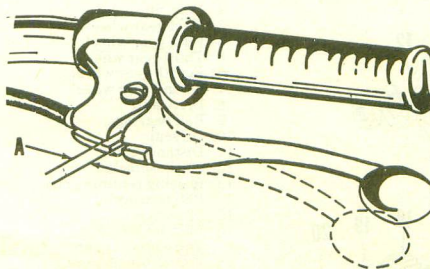

Fig. Y11-9—Adjust clutch cable to obtain 2-3mm free play at (A).

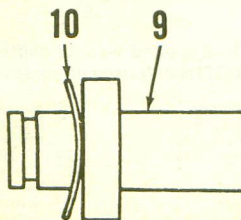

Fig. Y11-7—Install spacer (10) on piston (9) with concave side towards end of piston.

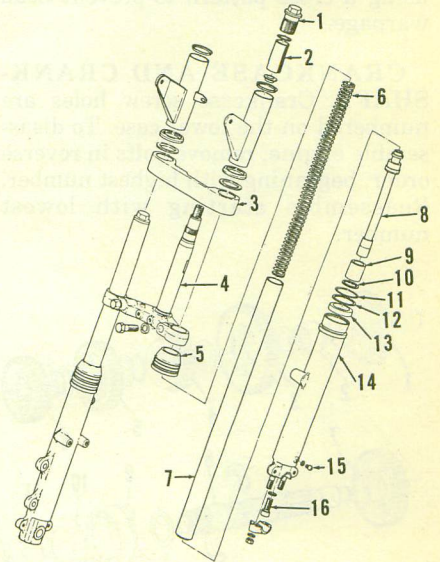

Fig. Y11-11—Exploded view of front suspension used on models RD350 and RD350A. Models RD250 and RD250A are similar.

- |                    |                         |
|--------------------|-------------------------|
| 1. Cap bolt        | 9. Piston               |
| 2. Spacer          | 10. Snap ring           |
| 3. Cover           | 11. Circlip             |
| 4. Steering stem   | 12. Washer              |
| 5. Dust boot       | 13. Seal                |
| 6. Spring          | 14. Outer fork tube     |
| 7. Inner fork tube | 15. Drain screw         |
| 8. Damper valve    | 16. Damper holding bolt |

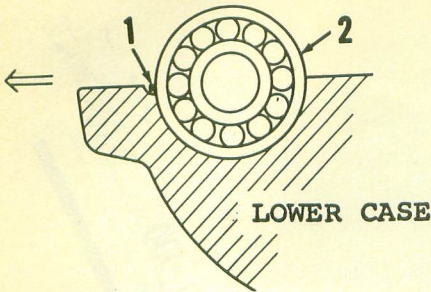

Fig. Y11-12-Crankshaft ball bearings have guide pins (1) that should be placed in recess in the lower crankcase half.

**REPAIRS**

**PISTON AND CYLINDER.** Pistons may be removed after removal of heads, exhaust pipes, carburetors, oil lines and cylinders. Use the following repair specifications:

Ring end gap

R5, R5B, R5C ..... 0.3-0.5mm  
(0.012-0.020 in.)

All other models ..... 0.2-0.4mm  
(0.008-0.016 in.)

Piston skirt to cylinder

clearance ..... 0.035-0.040mm  
(0.014-0.016 in.)

Cylinder taper or out of round 0.05mm  
(0.020 in.)

Measure piston skirt 3/8 inch from bottom of skirt at right angle to piston pin hole for cylinder clearance. Install rings with markings to the top. Install pistons with arrow toward front of engine (exhaust side). Torque cylinder head retaining nuts to 15 foot pounds using a cross pattern to prevent head warpage.

**CRANKCASE AND CRANK-SHAFT.** Crankcase screw holes are numbered on the lower case. To disassemble engine, remove bolts in reverse order, beginning with highest number. Reassemble starting with lowest number.

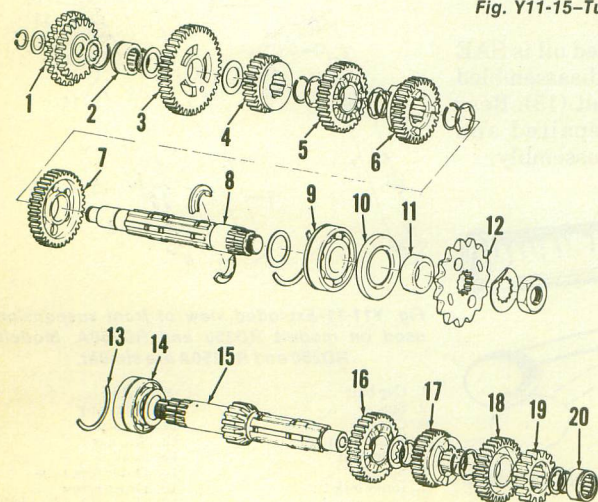

1. Snap ring
2. Shim
3. Idler gear assy.
4. Wave washer
5. Bearing locator
6. Bearing
7. Snap ring
8. Washer
9. First driven gear
10. Bearing
11. Fourth driven gear
12. Snap ring
13. Splined washer
14. Third driven gear
15. Sixth driven gear
16. Second driven gear
17. Output shaft
18. Shim
19. Bearing locator
20. Bearing
21. Seal
22. Spacer
23. Input shaft
24. Fourth drive gear
25. Washer
27. Third drive gear
28. Sixth drive gear
29. Second drive gear
30. Washer
31. Fifth drive gear
32. Snap ring
33. Bearing

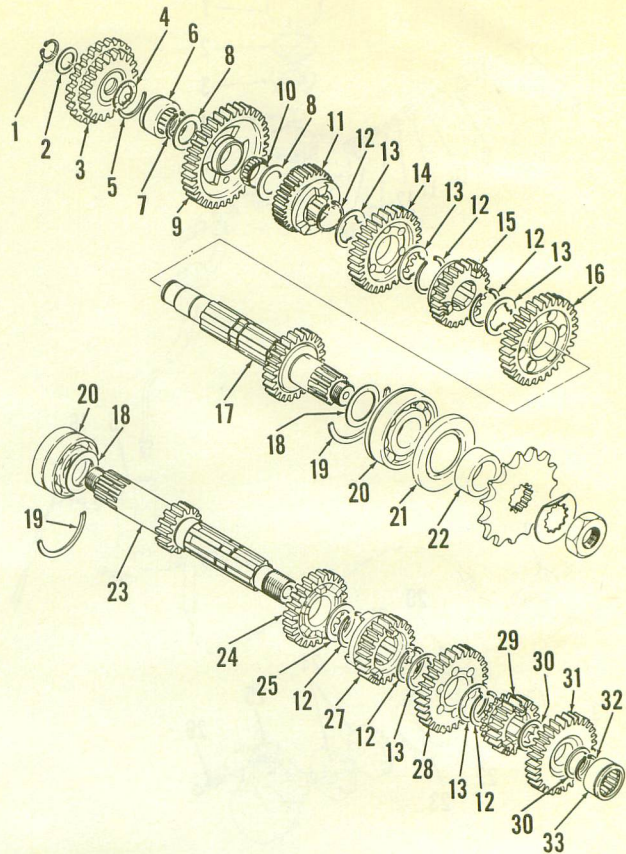

Fig. Y11-14-Exploded view of six speed transmission used on models RD250, RD250A, RD350 and RD350A.

Small end of connecting rod should move sideways (shake) no more than 2mm (0.078 in.). Crankshaft runout should be no more than 0.02mm (0.0008 in.) and side clearance between

connecting rod and crank cheek should be 0.1-0.3mm (0.004-0.012 in.). Align pin on the main bearings with the re-

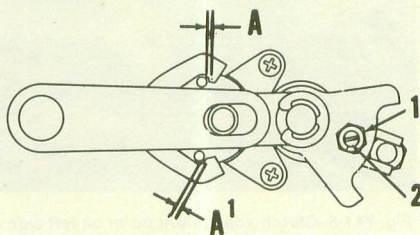

Fig. Y11-15-Turn eccentric screw (2) until clearance is (A) is equal.

Fig. Y11-13-Exploded view of DS7, R5, R5B and R5C transmission. Gears (5 & 16) are identical.

1. Idle gear assembly
2. Bearing
3. First gear wheel
4. Fifth gear wheel
5. Third gear wheel
6. Fourth gear wheel
7. Second gear wheel
8. Drive axle
9. Ball bearing
10. Oil seal
11. Distance collar
12. Chain sprocket
13. Bearing retaining clip
14. Ball bearing
15. Main axle
16. Fifth pinion gear
17. Third pinion gear
18. Fourth pinion gear
19. Second pinion gear
20. Needle bearing

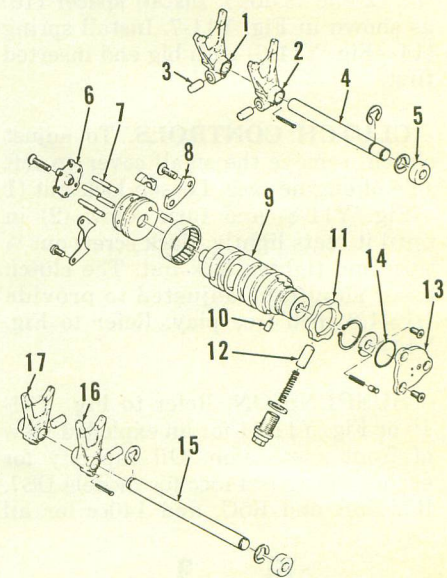

Fig. Y11-16-Exploded view of shifter assembly. Shift fork (17) is only used on six speed models.

- |                      |  |
|----------------------|--|
| 1. First shift fork  | 12. Stopper cam                                |
| 2. Second shift fork | 13. Neutral switch assembly                    |
| 3. Cam follower pin  | 14. "O" ring                                   |
| 4. Second shift fork | 15. First shift fork guide bar                 |
| 5. Blind plug        | 16. Second shift fork (interchangeable with 2) |
| 6. Slide plate       | 17. First shift fork (interchangeable with 1)  |
| 7. Dowel pins        |  |
| 8. Stopper plate     |  |
| 9. Shifting cam      |  |
| 10. Dowel pin        |  |
| 11. Stopper plate    |  |

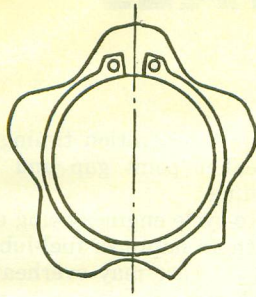

Fig. Y11-17—Position open end of snap ring on stopper plate (11—Fig. Y11-16) as shown.

cess in lower case half when reassembling. See Fig. Y11-12.

Models RD250, RD250A, RD350 and RD350A are equipped with a six speed transmission while all other models use a five speed transmission. Refer to Fig. Y11-13 or Y11-14 for an exploded

view of transmission. Shift mechanism is similar on all models but six speed models are equipped with an additional shift fork (17—Fig. Y11-16).

Inspect gears for wear, burning and broken teeth. Inspect shift forks for burning and wear.

Gear change lever arm should be adjusted so that clearance (A—Fig. Y11-15) is equal at both points. Loosen lock nut (1) and turn eccentric screw (2) until clearance is correct.

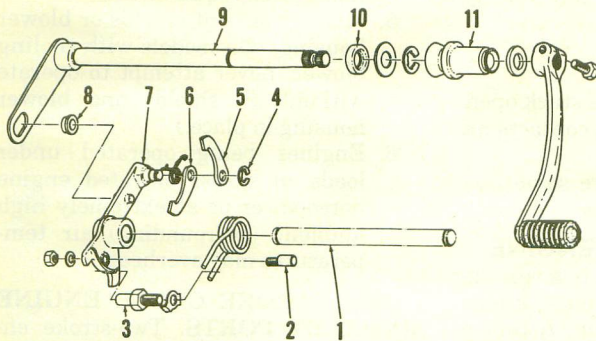

Fig. Y11-18—Exploded view of shifting linkage.

1. First shift fork guide bar
2. Eccentric screw
3. Stopper screw
4. Snap ring
5. Change lever
6. Change lever
7. Bracket
8. Change lever roller
9. Change shaft assembly
10. Oil seal
11. Sealing boot

**CLUTCH.** The clutch is wet multi-disc type. It has six molded cork friction plates and seven steel plates. Standard free length of a clutch spring is 36mm (1.41 in.). Springs should be renewed if 1mm (0.04 in.) shorter than standard. Standard thickness of a friction plate is 3MM (0.118 in.). Renew plates if wear is uneven or plates are less than 90% of original thickness.

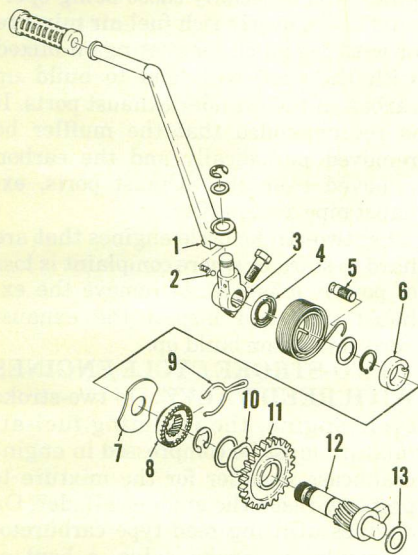
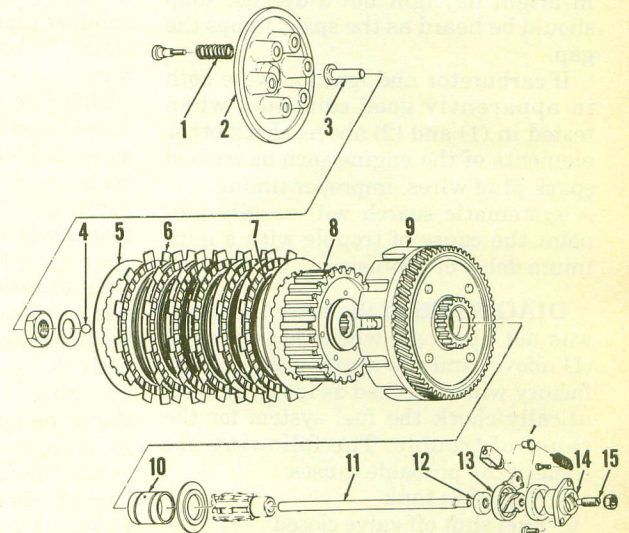

Fig. Y11-19—Exploded view of kick starter assembly.

- |                        |                        |
|------------------------|------------------------|
| 1. Kick lever          | 8. Ratchet wheel       |
| 2. Steel ball          | 9. Clip                |
| 3. Kick lever boss     | 10. Wave washer        |
| 4. Oil seal            | 11. Kick gear          |
| 5. Kick spring stopper | 12. Kick axle assembly |
| 6. Spacer              | 13. Washer             |
| 7. Spring cover        |                        |

Fig. Y11-20—Exploded view of typical clutch assembly.

1. Clutch spring
2. Pressure plate
3. Push rod
4. Ball
5. Steel clutch plate
6. Cork friction plate
7. Cushion ring
8. Clutch boss
9. Primary driven gear assembly
10. Spacer
11. Push rod
12. Push rod seal
13. Push lever assembly
14. Push screw housing
15. Clutch adjusting screw



# SERVICE FUNDAMENTALS

## TROUBLE SHOOTING

Most performance problems such as failure to start, failure to run properly or missing out are caused by malfunction of the ignition system or fuel system. The experienced serviceman generally develops and follows a logical sequence in trouble shooting which will most likely lead him quickly to the source of trouble. One such sequence might be as follows:

### FAILS TO START

1. Remove and examine spark plugs. If fuel is reaching the cylinder in proper amount, there should be an odor of gasoline on the plugs if they are cold. Too much fuel or oil can foul the plugs causing engine not to start. Fouled plugs are wet in appearance and easily detected. The presence of fouled plugs is not a sure indication that the trouble has been located, however. The engine might have started before fouling occurred if ignition system had been in good shape.

2. With spark plug removed, hold wire about  $\frac{1}{8}$  to  $\frac{1}{4}$  inch away from an unpainted part of the cylinder head or cylinder and crank the engine sharply. The resulting spark may not be visible in bright daylight but a distinct snap should be heard as the spark jumps the gap.

If carburetor and ignition were both in apparently good condition when tested in (1) and (2) above, check other elements of the engine such as crossed spark plug wires, improper timing, etc. A systematic search will usually pinpoint the cause of trouble with a minimum delay or confusion.

**DIAGNOSIS.** If the presence of fuel was not apparent when checked as in (1) above; and the spark seemed satisfactory when checked as in (2), systematically check the fuel system for the cause of trouble. The following are some of the probable causes:

- a. No fuel in tank
- b. Fuel shut off valve closed
- c. Fuel tank vent closed or plugged
- d. Carburetor not primed
- e. Choke or starting valve incorrectly used or malfunctioning
- f. Water or dirt in the fuel
- g. Fuel line pinched or kinked
- h. Clogged fuel shut off, fuel line or filter
- i. Carburetor dirty or incorrectly adjusted.

If ignition trouble was indicated when checked as outlined in (2) above, check the electrical system for causes of trouble. Some probable causes are as follows:

- a. Battery voltage low (Battery ignition models)
- b. Ignition breaker points improperly adjusted
- c. Shorted wire or stop switch
- d. Open (broken) wire
- e. Loosen or corroded connections
- f. Condenser shorted
- g. Improperly mounted coil (Incorrect gap between primary coil and flywheel magnets)
- h. Flywheel loose
- i. Faulty coil
- j. Ignition breaker points stuck open
- k. Ignition breaker point contacts pitted, burned or dirty  
(New ignition points are sometimes coated with protective oil).

### FAULTY RUNNING ENGINE

The diagnosis of trouble in a running engine depends on experience, knowledge and acute observation. A continuous miss on one cylinder of a two cylinder engine can usually be isolated by observing the items listed in the previous paragraphs (FAILS TO START).

Faults such as not enough power (or speed) can usually be traced to improper tuning. Make sure that air filter is clean and in good condition and that exhaust pipe and muffler are open (not clogged). Ignition timing and carburetor(s) must be correctly adjusted. The carburetor jet sizes, clip position in valve needle and idle mixture needle settings listed in the individual service sections in this manual are "normal" settings. Altitude above sea level, riders weight, driving habits etc. may require different sizes and settings than those listed. On motorcycles with two carburetors, make certain that the throttles are synchronized to open exactly the same amount. Ignition timing on two cylinder motorcycles must be the same for each cylinder. In addition to normal engine tuning procedures, check the following: Sprocket sizes incorrect. Drive chain too tight or too loose. Tire pressure too low. Brakes dragging. Clutch slipping. Damaged pistons, rings and/or cylinders. Loose cylinder head nuts or leaking head gasket. Leaking crankcase seals.

### SPECIAL NOTES ON TROUBLE SHOOTING

**ENGINE OVERHEATS.** The following lists some probable causes of engine overheating.

1. Check for dirt or debris accumulated on or between cooling fins on cylinder and head.
2. Too lean fuel-air adjustment of carburetor.

3. Improper ignition timing. Check breaker point gap and ignition timing.
4. Two-cycle engines being operated with an improper fuel-lubricating oil mixture may overheat due to lack of lubrication; refer to appropriate engine service section in this manual for recommended lubrication requirements.
5. Missing or bent shields or blower housing. (On models with cooling blower, never attempt to operate without all shields and blower housing in place.)
6. Engines being operated under loads in excess of rated engine horsepower or at extremely high ambient (surrounding) air temperatures may overheat.

### TWO-STROKE CYCLE ENGINE

**EXHAUST PORTS.** Two-stroke engines, and especially those being operated on an overly rich fuel-air mixture or with too much lubricating oil mixed with the fuel, will tend to build up carbon in the cylinder exhaust ports. It is recommended that the muffler be removed periodically and the carbon removed from the exhaust ports, exhaust pipe and muffler.

On two-stroke cycle engines that are hard to start, or where complaint is loss of power, it is wise to remove the exhaust pipe and inspect the exhaust ports for carbon build up.

**TWO-STROKE CYCLE ENGINES WITH REED VALVE.** On two-stroke cycle engine, the incoming fuel-air mixture must be compressed in engine crankcase in order for the mixture to properly reach the engine cylinder. On engines utilizing reed type carburetor to crankcase intake valve, a bent or broken reed will not allow compression build up in the crankcase. Thus, if such an engine seems otherwise OK, remove and inspect the reed valve unit. Refer to appropriate engine repair section in this manual for information on individual two-stroke cycle engine models.

### SPARK PLUG

The appearance of the spark plug will be altered by use and careful examination of the plug tip can contribute useful information. It must be remembered that contributing factors differ in two stroke cycle and four stroke cycle engine operation and although the appearance of two spark plugs may be similar, the corrective measures may depend on whether the engine is of two-cycle or four-cycle design. The accompanying pictures (Figs.

## FUNDAMENTALS

2-1 thru 2-8) are provided by Champion Spark Plug Company to illustrate typical conditions. Listed also are the probable causes and suggested corrective measures.

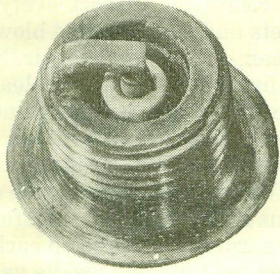

Fig. 2-1—Normal plug appearance. Insulator is light tan to gray in color and electrodes are not burned. Renew plug at regular intervals as recommended by manufacturer.

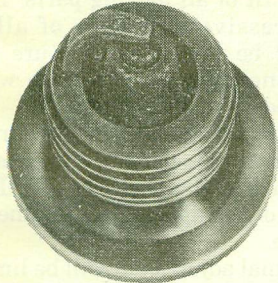

Fig. 2-2—Appearance of spark plug indicating cold fouling. Cause of cold fouling may be use of a too-cold plug, excessive idling or light loads, carburetor choke (or starting valve) out of adjustment, carburetor adjusted too "rich" or air filter dirty or wet.

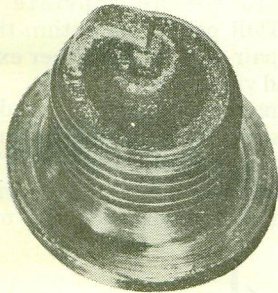

Fig. 2-3—Appearance of spark plug indicating wet fouling; a wet, black oil film is over entire firing end of plug. Cause may be incorrect fuel-oil ratio, incorrectly adjusted oil pump or leakage of transmission oil into crankcase (through crankshaft seals).

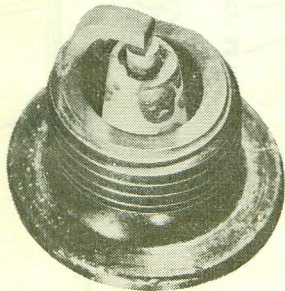

Fig. 2-4—Appearance of spark plug indicating splash fouling. Carbon deposits which have accumulated during a long period may be loosened suddenly upon installation of new spark plugs. When the newly tuned engine is placed under load, excess carbon deposits shed off the piston and are thrown against the hot insulator surface. These deposits can foul the plug, but can be removed from the plug by cleaning.

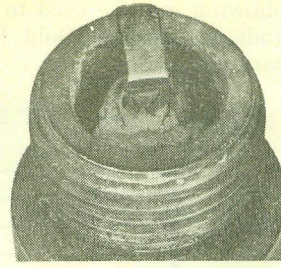

Fig. 2-5—Appearance of spark plug indicating core bridging. This condition is similar to, and caused by, the same combustion chamber deposits that cause splash fouling (Fig. 2-4). When the deposits become lodged between the insulator and the spark plug shell, an electrical bridge is formed, resulting in plug misfire.

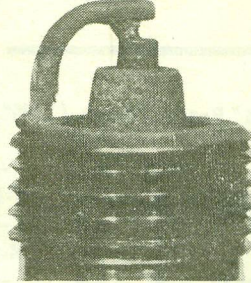

Fig. 2-6—Gap bridging usually results from excessive carbon deposits from prolonged usage, improper oil or incorrect oil to fuel ratio or high-speed operation immediately upon starting.

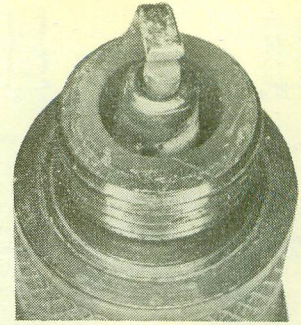

Fig. 2-7—If plug has been in use for some time electrodes may be badly eroded. Could be caused by lean carburetor mixture, fast timing, overloading, improper cooling or spark plug heat range too hot.

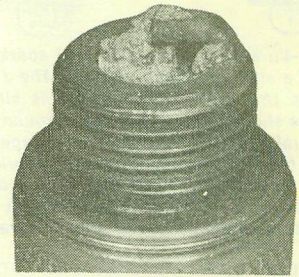

Fig. 2-8—Gray, metallic aluminum deposits on plug. This condition is caused by internal engine damage. Engine should be overhauled and cause of damage corrected.

## MAINTENANCE

### SPARK PLUG

The recommended type of spark plug, heat range and electrode gap is listed in the appropriate MAINTENANCE section for each motorcycle. Under light loads, low speeds or only short trips, a spark plug of the same size with a higher (hotter) heat range may be installed. If subjected to heavy loads, high speeds and/or long (cross country) trips, a colder plug may be necessary.

The spark plug electrode gap should be adjusted on most plugs by bending the ground electrode. Refer to Fig. 2-10. The ground electrode for some extremely cold (racing) plugs is constructed as shown by "COLD PLUG" in

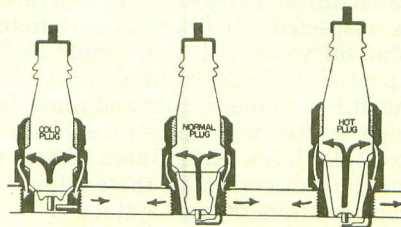

Fig. 2-9—A principal characteristic of a "COLD" plug is that it has a shorter path for heat to travel from the insulator tip to the metal shell than the "HOT" plug shown at the right.

Fig. 2-9 and electrode gap is pre-set or adjusted with a special tool.

Spark plugs are usually cleaned by abrasive action commonly referred to as "sand blasting." Actually, ordinary sand is not used, but a special abrasive which is nonconductive to electricity even when melted, thus the abrasive cannot short out the plug current. Extreme care should be used in cleaning the plugs after sand blasting; however,

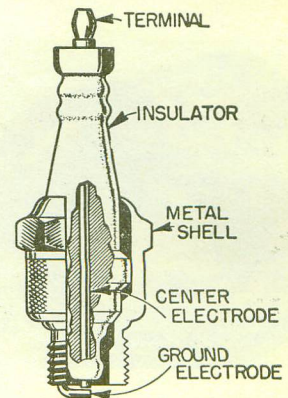

Fig. 2-10—Cross sectional view of spark plug showing typical construction and nomenclature. Recommended gap between center electrode and ground electrode is listed in appropriate section for each motorcycle.

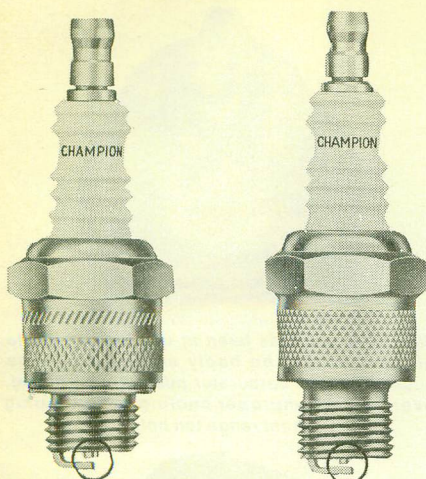

Fig. 2-11—View of a Champion J-8J spark plug (left) and a similar J-8 plug on right. The J suffix indicates that ground electrode is slightly shorter as shown. Plugs with short ground electrode usually require less ignition voltage than standard type and lessen the chance of bridging between electrodes. The short ground electrode operates cooler than standard length even though plugs are considered same heat range.

as any particles of abrasive left on the plug may cause damage to piston rings, piston or cylinder walls.

After plug is cleaned by abrasive, and before gap is set, the electrode surfaces between the grounded and insulated electrodes should be cleaned and returned as nearly as possible to original shape by filing with a point file. Failure to properly dress the points can result in high secondary voltage requirements, and misfire of the plugs.

CAUTION: Use special caution when filing the electrodes of spark plugs using precious metal electrodes. Fig. 2-11A shows the center electrode of a Champion "Gold Palladium" spark plug which has been bent by filing. Precious metal electrodes are usually softer than normal plugs and easily damaged by filing. Electrode gap for plugs with precious metal electrodes can be set for less gap than other spark plugs.

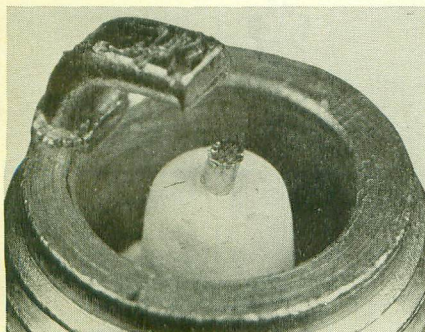

Fig. 2-11A—Use care to prevent damage to the electrodes, especially those made of precious metals. The center electrode shown has been roughened, shortened and bent by filing. The plug shown is a Champion "Gold Palladium" type.

The following may be used to compare standard types to "Gold Palladium" spark plugs:

14mm / 3/8" Reach		14mm / .472" Reach	
—	—	HOT	—
J-8J	—	↑	L-86
—	UJ-11G	—	—
J-7J	—	—	—
—	UJ-7G	—	L-81
J-6J	—	—	L-6G
—	—	—	—
J-4J	—	—	L-78
—	—	—	L-3G
J-57R	—	COLD	L-77J
—	—	—	L-2G

14mm / 3/8" Reach		18mm / .445" Reach	
—	—	HOT	K-13
—	—	↑	—
N-5	—	—	K-9
—	—	—	K-8G
N-4	N-4G	—	K-8
—	—	—	K-5G
N-3	N-3G	—	K-7
—	—	—	—
N-2	N-2G	—	K-60R*
—	—	COLD	K-57R*
—	—	—	K-2G

\* .500" Reach

It is usually necessary to clean or renew spark plugs shortly after overhauling the engine. The oil used to coat engine parts during assembly may foul the plugs quickly.

**CARBURETOR**

The bulk of carburetor service consists of cleaning, inspection and adjustment. After considerable service it may become necessary to overhaul the carburetor and renew worn parts to restore original operating efficiency. Although carburetor condition affects engine operating economy and power, ignition and engine compression must also be considered to determine and correct causes.

Before dismantling carburetor for cleaning and inspection, clean all external surfaces and remove accumulated dirt and grease. If fuel starvation is suspected, all filters in carburetor, shut-off valve and tank should be inspected. Because of inadequate fuel handling methods, rust and other foreign matter may sometimes block or partially block these filters. Under no circumstances should these filters be removed from the fuel system. If filters are removed, the blockage will most likely occur within the carburetor and cleaning will be frequent and more difficult.

Refer to appropriate engine repair section for carburetor exploded or cross sectional views. Disassemble the carburetor and note any discrepancies which may cause a malfunction. Thoroughly clean and inspect every part. Wash jets and passages and blow clear with clean, dry, compressed air. NOTE: Do not use a drill or wire to clean jets, because the possible enlargement of holes will disturb calibration. Measurement of jets to determine extent of wear is difficult and installation of new parts usually assures satisfaction. Sizes are usually stamped on each jet.

Inspect float pin and needle valve for wear and renew if necessary. Check metal floats for leaks and dual type floats for alignment of float sections. Check fit of all moving parts. Binding or excessive clearance of all parts should be corrected. Mixture adjustment needles must not be worn or grooved.

When reassembling, be sure float level (or fuel level) is properly adjusted as listed in the CARBURETOR paragraph of the appropriate engine repair section.

Normal adjustment will be limited to replacement of recommended standard size jets and turning idle mixture needle (screw); however, the following procedure may be useful for carburetors that are particularly hard to adjust. Refer to the appropriate CARBURETOR paragraph within the specific repair section for further explanation and views of carburetors.

Idle mixture adjustment needle controls mixture from idle to approximately 1/8 throttle opening. Throttle slide cut-away (Fig. 2-12), on variable venturi carburetors, controls mixture

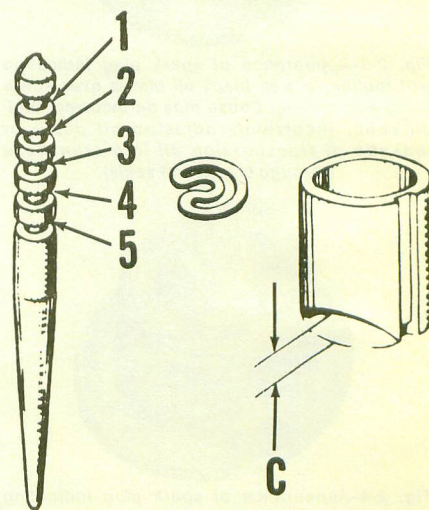

Fig. 2-12—View of slide type throttle valve. A large cut-away (C) leans the mixture in the 1/8-1/4 throttle range. Installation of clip in a groove nearer the top (such as No. 1) of valve needle leans the mixture in the 1/4-3/4 throttle opening range.

from 1/8 to 1/4 throttle opening. A larger cut-away leans the mixture in this range. The valve needle located in sliding venturi, controls mixture from 1/4 to 3/4 throttle opening. Lowering the needle in the slide leans mixture. The size of the main jet controls mixture from 3/4 to full open throttle.

When two carburetors are used on two cylinder engines, mixture adjustments are sometimes facilitated by removing the spark plug wire from the other cylinder while tuning. Setting for the two carburetors should not differ greatly. Large differences in mixture settings for proper engine operation indicates air leak in inlet manifold, faulty carburetor or engine internal faults.

**IGNITION AND ELECTRICAL**

The fundamentals of ignition and electrical system service are outlined in the following paragraphs. Refer to the appropriate heading for type of system being inspected or overhauled. A simple, easily constructed test lamp is shown in Fig. 2-13. A similar test lamp or Ohmmeter can be used to facilitate repair.

**Battery Ignition**

Repair is usually limited to renewal of breaker points and/or condenser and adjustment of ignition timing. Refer to the appropriate MAINTENANCE section for recommended breaker point gap and ignition timing for each model.

**BREAKER POINTS.** Using a small screwdriver, separate and inspect condition of contacts. If burned or deeply pitted, points should be renewed. If contacts are clean to grayish in color, disconnect condenser and coil lead wires from breaker point terminal. Connect one lead (C1—Fig. 2-13) to the

insulated breaker point terminal and the other (C2) to engine (ground). Light should burn with points closed and go out with points open. If light does not burn, little or no contact is indicated and points should be cleaned or renewed and contact maximum gap should be reset. NOTE: In some cases, new breaker point contact surfaces may be coated with oil or wax. If light does not go out when points are opened, breaker arm insulation is defective and points should be renewed.

Adjust breaker point gap as follows unless manufacturer specifies adjusting breaker gap to obtain correct ignition timing. First, turn engine so that points are closed to be sure that the contact surfaces are in alignment and seat squarely. Then, turn engine so that breaker point opening is maximum and adjust breaker gap to manufacturer's specification. Be sure to recheck gap after tightening breaker point base retaining screws.

**CONDENSER.** To check condition of the condenser without special test equipment, proceed as follows: The condenser case and wire should be visually checked for any obvious damage. Connect one end of the test lamp (C1—Fig. 2-13) to terminal at end of condenser wire and other end to condenser case. If light goes on, condenser is shorted and should be renewed. It is usually a good practice to renew condenser when new breaker points are installed.

**IGNITION COIL.** If a coil tester is available, condition of coil can be checked. However, if tester is not available, a reasonably satisfactory performance test can be made as follows:

Disconnect high tension wire from spark plug. Turn engine so that cam has allowed breaker points to close. With ignition switch on, open and close points with small screwdriver while holding high tension lead about 1/8 to 1/4-inch away from engine ground. A bright blue spark should snap across

the gap between spark plug wire and ground each time the points are opened. If no spark occurs, or spark is weak and yellow-orange, renewal of the ignition coil is indicated.

Sometimes, an ignition coil may perform satisfactorily when cold but fail after engine has run for some time and coil is hot. Check coil when hot if this condition is indicated.

**IGNITION TIMING.** On some engines, ignition timing is non-adjustable and a certain breaker point gap is specified. On other engines, timing is adjustable by changing the position of the stator plate with a specified breaker point gap or by simply varying the breaker point gap to obtain correct timing. Ignition timing is usually specified either in degrees of engine (crankshaft) rotation or in piston travel before the piston reaches top dead center position.

Some engines may have timing marks or locating pin to locate the crankshaft at proper position for the ignition spark to occur (breaker points begin to open). If not, it will be necessary to measure piston travel or install a degree wheel on engine crankshaft. Refer to Figs. 2-15 and 2-16.

A timing light as shown in Fig. 2-13 is a valuable aid in checking or adjusting engine timing. After disconnecting the ignition coil lead from the breaker point terminal, connect the leads of the timing light as shown. If timing is adjustable by moving the stator plate, be sure that the breaker point gap is adjusted as specified. Then to check timing, slowly turn engine in normal direction of rotation past the point at which ignition spark should occur. The timing light should be on, then go out (breaker points open) just as the correct timing location is passed. If not, turn engine to proper timing

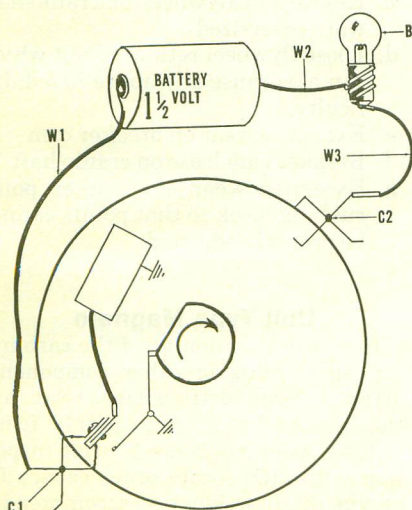

Fig. 2-13—Drawing of a simple test lamp for checking ignition timing and various other complete circuits.

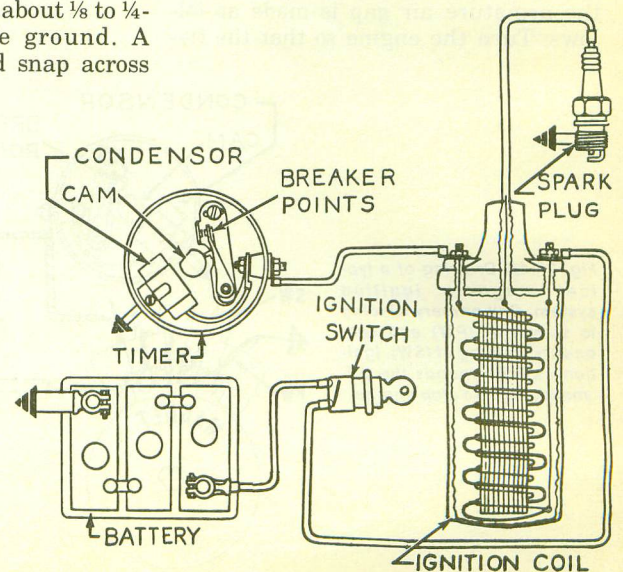

Fig. 2-14—Drawing of a typical battery ignition system for single cylinder engine. Ignition switch closes to complete the circuit.

location and adjust timing by relocating the breaker point base plate or varying the breaker contact gap as specified by appropriate section for each model. Recheck timing to be sure adjustment is correct.

If ignition is equipped with advancing mechanism (manual control or automatic, centrifugal advance), make sure timing is checked when fully advanced. On some models, timing can be checked using an automotive, power timing light when engine is running.

**FLYWHEEL MAGNETO**

Repair is usually limited to renewal of breaker points and/or condenser and adjustment of ignition timing. Refer to the appropriate MAINTENANCE section for recommended breaker point gap and ignition timing for each model.

**BREAKER POINTS.** The same general service procedure is used as in the preceding paragraph for BATTERY IGNITION. Holes are usually provided in the flywheel for adjustment, however flywheel usually must be removed for renewal of ignition points.

**CONDENSER.** The same general procedure is used to check condenser as outlined in previous BATTERY IGNITION system. Condenser is usually located under the flywheel.

**ARMATURE AIR GAP.** To fully concentrate the magnetic field of the flywheel, magnets pass as closely to the armature core as possible without danger of metal to metal contact. The clearance between the flywheel magnets and the legs of the armature core is called the armature air gap.

On magnetos where the armature and high tension coil are located outside of the flywheel rim, adjustment of the armature air gap is made as follows: Turn the engine so that the fly-

wheel magnets are located directly under the legs of the armature core and check the clearance between the armature core and flywheel magnets. If the measured clearance is not within manufacturers specifications, loosen the armature mounting screws and place shims of thickness equal to minimum air gap specification between the magnets and armature core. The magnets will pull the armature core against the shim stock. Tighten the armature core mounting screws, remove the shim stock and turn the engine through several revolutions to be sure the flywheel does not contact the armature core.

Where the armature core is located under or behind the flywheel, the following methods may be used to check and adjust armature air gap: On some engines, slots or openings are provided in the flywheel through which the armature air gap can be checked. Some engine manufacturers provide a cut-away flywheel that can be installed temporarily for checking the armature air gap.

Another method of checking the armature air gap is to remove the flywheel and place a layer of plastic tape equal to the minimum specified air gap over the legs of the armature core. Reinstall flywheel and turn engine through several revolutions and remove flywheel; no evidence of contact between the flywheel magnets and plastic tape should be noticed. Then cover the legs of the armature core with a layer of tape of thickness equal to the maximum specified air gap; then, reinstall flywheel and turn engine through several revolutions. Indication of the flywheel magnets contacting the plastic tape should be noticed after the flywheel is again

removed. If the magnets contact the first thin layer of tape applied to the armature core legs, or if they do not contact the second thicker layer of tape, armature air gap is not within specifications and should be adjusted. NOTE: Before loosening armature core mounting screws, scribe a mark on mounting plate against edge of armature core so that adjustment of air gap can be gaged.

**MAGNETO EDGE GAP.** The point of maximum acceleration of the movement of the flywheel magnetic field through the high tension coil (and therefore, the point of maximum current induced in the primary coil windings) occurs when the trailing edge of the flywheel magnet is slightly past the last leg of the armature core. The exact point of maximum primary current is determined by using electrical measuring devices, the distance between the trailing edge of the flywheel magnet and the leg of the armature core at this point is measured and becomes a service specification. This distance, which is stated either in thousandths of an inch or in degrees of flywheel rotation, is called the Edge Gap or "E" Gap.

For maximum strength of the ignition spark, the breaker points should just start to open when the flywheel magnets are at the specified edge gap position. Usually, edge gap is non-adjustable and will be maintained at the proper dimension if the contact breaker points are adjusted to the recommended gap and the correct breaker cam is installed. However, magneto edge gap can change (and spark intensity thereby reduced) due to the following:

- a. Flywheel drive key sheared
- b. Flywheel drive key worn (loose)
- c. Keyway in flywheel or crankshaft worn (oversized)
- d. Loose flywheel retaining nut which can also cause any above listed difficulty.
- e. Excessive wear on breaker cam
- f. Breaker cam loose on crankshaft
- g. Excessive wear on breaker point rubbing block so that points cannot be properly adjusted.

Fig. 2-14A—Drawing of a typical magneto ignition system. Coil primary winding is shown at (PW) and secondary winding at (SW). Ignition switch grounds the primary circuit to stop engine.

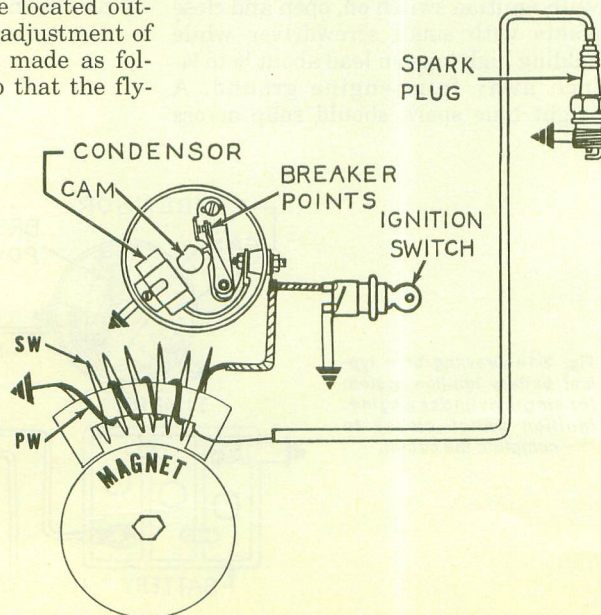

**Unit Type Magneto**

Improper functioning of the carburetor, spark plug or other components often causes difficulties that are thought to be an improperly functioning magneto. Since a brief inspection will often locate other causes for engine malfunction, it is recommended that one be certain the magneto is at fault before opening the magneto housing.

**BREAKER POINTS AND CONDENSER.** The same general procedure is used to service and check as outlined in previous paragraphs for BATTERY IGNITION system. Usually complete magneto housing is rotated when adjusting ignition timing.

**COIL.** The ignition coil can be tested without removing the coil from the housing. The instruction provided with coil tester should have coil test specifications listed.

**ROTOR.** Usually, service on the magneto rotor is limited to renewal of bushings or bearings, if damaged. Check to be sure rotor turns freely and does not drag or have excessive end play.

**MAGNETO INSTALLATION.** When installing a unit type magneto on an engine, refer to IGNITION paragraph in appropriate engine repair section for magneto to engine timing information.

**Energy Transfer System**

The energy transfer ignition system operates very much as the previously described flywheel magneto system except the components are not in one area of the engine. Refer to Fig. 2-14B. The rotor (rotating magnet) is attached to the crankshaft with the low tension coil around it. As the magnet revolves, current generated in the low tension coil (LT) is grounded by the closed ignition breaker points. When the current generated in the low tension coil reaches its maximum voltage, the ignition points open causing a rapid build up of the primary current in the high tension ignition coil. The rapid build-up of current in the high tension coil primary windings (PW) induces a high tension current in the secondary windings (SW) in much the same way as the rapid collapse in a battery ignition system. A special high tension coil is used and cannot be interchanged with a battery ignition coil.

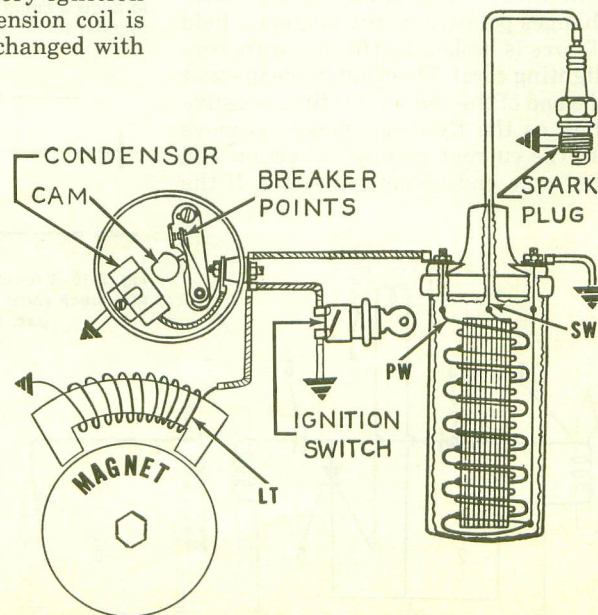

Fig. 2-14B—Drawing of a typical energy transfer ignition system. Low tension generating coil is shown at (LT). When breaker points are closed, current completes circuit through the points. When breaker points open, current rushes into the high tension coil primary winding (PW) and induces voltage in the secondary (SW). Ignition switch grounds the low tension circuit to stop engine.

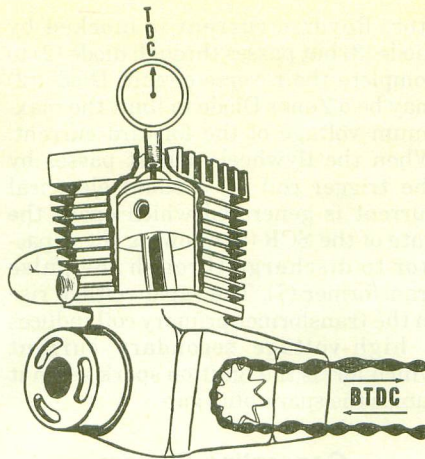

Fig. 2-15—On some engines, it will be necessary to measure piston travel with rule, dial indicator or special timing gage when adjusting or checking ignition timing. Arrows show direction to move chain to position piston Before Top Dead Center after TDC has been located.

If the ignition timing cam and rotating magnet (rotor) are separately mounted, each must be individually timed with crankshaft to obtain the correct magneto edge gap. Refer to preceding paragraph in FLYWHEEL MAGNETO section for explanation of EDGE GAP. On models where the rotor is keyed to the crankshaft, advancing the time of ignition breaker point opening causes a low voltage in the primary winding resulting in insufficient secondary voltage. If the rotor is moveable on the crankshaft, it is important that the rotor position and ignition breaker point opening not be changed from the recommended settings listed in the repair section of this manual.

Make certain that the high tension coil is securely attached. On many

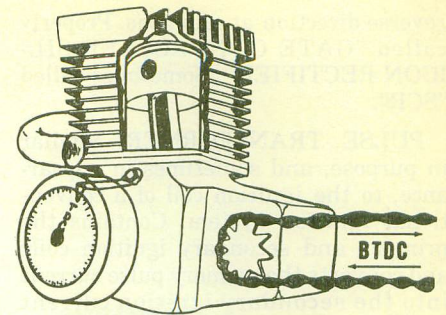

Fig. 2-16—View of typical degree wheel installation for checking ignition timing. Degree wheel can also be used for checking rotary valve timing and piston port opening.

models, the attaching screws provide the ground for the high tension coil. If not mounted correctly, ignition will be affected.

**Capacitor Discharge System**

This system differs radically from conventional units in that a relatively high voltage current is fed into a capacitor which discharges through a pulse transformer (ignition coil) to generate the ignition spark. The secondary current is induced by the rapid build-up rather than by collapse of the primary current. The result is a high-energy ignition spark ideally suited to high-speed, two-stroke engine operation.

One development which made the new systems possible was the introduction of semi-conductors suitable for ignition system control. While solid state technology and the capacitor discharge system are not interdependent they are uniquely compatible and each has features which are desirable from the standpoint of reliability and performance.

A flywheel magneto is most generally used as the primary current source in engines of the size and type found on motorcycles because of the relatively high voltage obtainable and compact, light-weight parts available. If battery current is used as the power source, it must be amplified or converted to obtain the necessary voltage.

The introduction of the new ignition systems is bringing unfamiliar words into use which might be defined in the following non-technical terms:

**CAPACITOR.** The storage capacitor, or condenser.

**DIODE.** A device which will allow electrical current to flow in one direction but will block a reverse flow.

**GATE CONTROLLED SWITCH.** A semi-conductor which will pass the flow of electrical current in one direction only when a second, small "TRIGGER CURRENT" opens the "GATE". Current will not flow in the

reverse direction at any time. Properly called "GATE CONTROLLED SILICON RECTIFIER". Sometimes called "SCR".

**PULSE TRANSFORMER.** Similar in purpose, and sometimes in appearance, to the ignition coil of a conventional ignition system. Contains the primary and secondary ignition coils and converts the primary pulse current into the secondary ignition current which fires the plug. Cannot be interchanged with regular ignition coil.

**RECTIFIER.** Any device which allows the flow of current in one direction only, or converts Alternating Current to Direct Current. Diodes are sometimes used in combination to form a BRIDGE RECTIFIER.

**SCR.** See GATE CONTROLLED SWITCH.

**SEMI-CONDUCTOR.** Any of several materials which permit partial or controlled flow of electrical current. Used in the manufacture of Diodes, Rectifiers, SCR's, Thermistors, Thyristors, etc.

**SILICON SWITCH.** See GATE CONTROLLED SILICON SWITCH.

**SOLID STATE.** That branch of electronic technology which deals with the use of semi-conductors as control devices. See SEMI-CONDUCTOR.

**THERMISTOR.** A solid state regulating device which decreases in resistance as its temperature rises. Used for "Temperature Compensating" a control circuit.

**THYRISTOR.** A "Safety Valve" placed in the circuit which will not pass current in either direction but is used to provide surge protection for the other elements.

**TRIGGER.** The timed, small current which controls, or opens, the "GATE", thus initiating the spark.

**ZENER DIODE.** A Zener Diode will permit free flow of current in one direction, and will also permit current to flow in the opposite direction when the voltage reaches a pre-determined level.

Fig. 2-16A shows a circuit diagram of a typical single cylinder, capacitor discharge, breakerless ignition system using permanent flywheel magnets as the energy source. The magnets pass by the input generating coil (1) to charge the capacitor (6), then by the trigger coil (4) to open the gate and permit the discharge pulse to enter the pulse transformer (7) and generate the spark which fires the plug (8). Only half of the generated current passes through diode (3) to charge the capac-

itor. Reverse current is blocked by diode (3) but passes through diode (2) to complete the reverse circuit. Diode (2) may be a Zener Diode to limit the maximum voltage of the forward current. When the flywheel magnet passes by the trigger coil (4) a small electrical current is generated which opens the gate of the SCR (5) allowing the capacitor to discharge through the pulse transformer (7). The rapid voltage rise in the transformer primary coil induces a high-voltage secondary current which forms the ignition spark when it jumps the spark plug gap.

**Generating System**

**FLYWHEEL ALTERNATORS.**

Alternating current is readily available on engines using a flywheel magneto or energy transfer ignition system by installing an additional armature core (lighting coil) in a position similar to the ignition coil. The principle of this type of system is similar to the flywheel magneto, however only one winding is necessary. The voltage and amperage can be limited by the resistance (length, diameter, etc.) of the wire used in the lighting coil windings and the alternating current (AC) generated is satisfactory for lighting requirements. However, if a battery is used, the generated Alternating Current must be changed to Direct Current (DC) usually via a rectifier.

**RECTIFIER.** Repair of a rectifier is limited to renewal of the unit, however certain precautions and inspections may be more easily accomplished after a brief description of its operation.

Direct Current (DC), like the type available from a battery, has an established negative terminal and a positive terminal. Alternating current such as generated by a magneto or alternator changes polarity as the magnetic field of force is broken by the armature core (lighting core). This simply means that one end of the coil wire is first negative then as the flywheel (magnets) move on, the current reverses direction and the same end becomes positive. If the

AC current were connected to a battery (DC), the current would first flow into the battery, then as the AC changed polarity (direction) it would withdraw the same amount.

Electricity in a wire is similar to liquid in a pipe. In a pipe, a check valve can be installed to allow a liquid to flow only in one direction as shown in Fig. 2-17. A rectifier is a similar valve for an electrical system Fig. 2-18. The simplicity of modern rectifier construction is shown in Fig. 2-19. The changing of AC polarity can be shown on elaborate testing equipment similar to drawing (Fig. 2-20). Where the curved line crosses the center line is

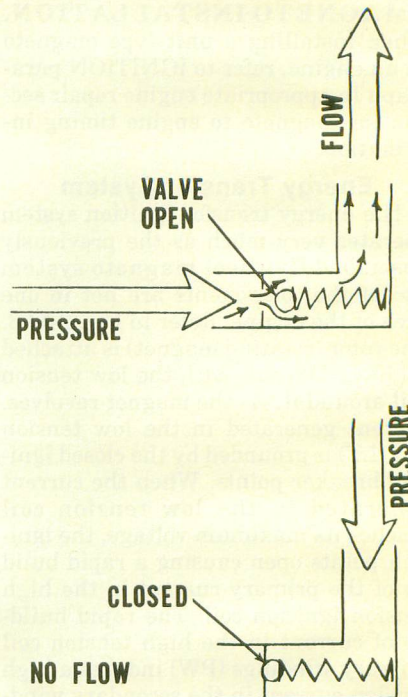

Fig. 2-17-A check valve can be installed in a pipe to allow a liquid to flow only in one direction. A rectifier serves a similar function in an electrical system.

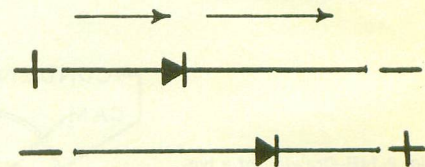

Fig. 2-18-A rectifier serves a similar function to the check valve in Fig. 2-17 allowing current to pass only in one direction.

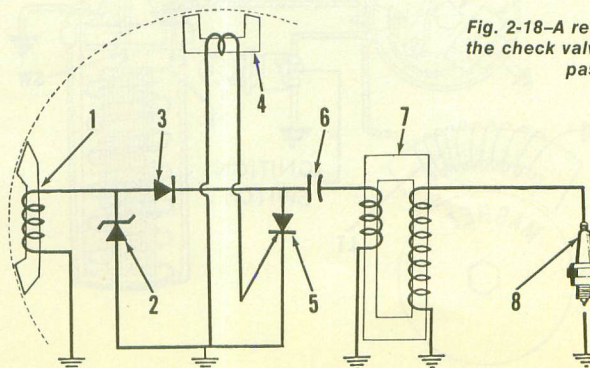

Fig. 2-16A-Schematic diagram of a typical Capacitor Discharge "Solid State" Ignition system.

- 1. Generating coil
- 2. Zener diode
- 3. Diode
- 4. Trigger coil
- 5. Gate Controlled Switch (SCR)
- 6. Capacitor
- 7. Pulse transformer (coil)
- 8. Spark plug

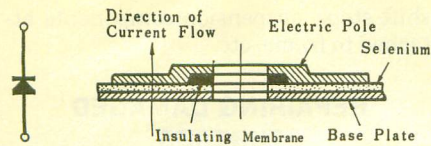

Fig. 2-19—Drawing showing the simplicity of typical modern rectifier construction. Type shown is Selenium.

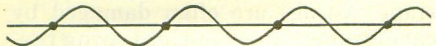

Fig. 2-20—Elaborate testing equipment shows alternating current as a wave. The curved "S" line between the dots is called a cycle.

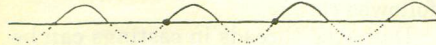

Fig. 2-21—Alternating current shown by dotted lines is unused when using only one rectifier.

the exact time that the current reverses polarity. Installation of a rectifier stops current flow in one direction so the current flow can be pictured as shown by the solid line in Fig. 2-21. Half of the current generated (shown by the broken lines) is lost. A typical, simple, complete system is shown in Fig. 2-22.

In order to use the current which is normally lost in the previously described simple system, a combination of rectifiers can be used. Normally they are constructed as one rectifying unit. Fig. 2-23 shows a typical complete system.

Rectifiers must be installed to allow current flow from the alternator into the battery. If the rectifier terminals are reversed, current from the battery will be fed into the lighting coil and coil and/or rectifier will be damaged by the resulting short circuit. The rectifier may be damaged if the system is operated without the battery connected or if battery terminals are reversed. Direction of current flow through the rectifier can be easily checked with a battery, light and wire (or ohmmeter) as shown in Fig. 2-24.

If the rectifier will not pass current in either direction using the simple test shown in Fig. 2-24, or if light continues to burn with connections reversed, rectifier may be considered faulty. Paint should not be scraped from rectifier plates and plates should not be discolored (from heat) or bent. The center bolt torque is pre-set and should NOT be disturbed.

**LUBRICATION**

Refer to the appropriate MAINTENANCE section for each model for recommended type and quantity of lubrication oils used in engine, gear box and primary (engine to transmission) drive case.

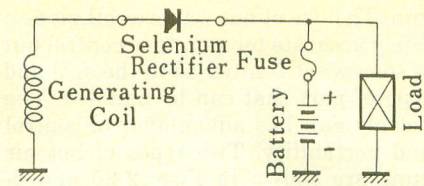

Fig. 2-22—A complete, simple electrical system using only one rectifier is basically as shown.

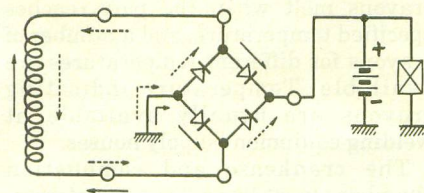

Fig. 2-23—Wiring diagram of full wave rectifying system. The four rectifiers shown are usually constructed as one unit.

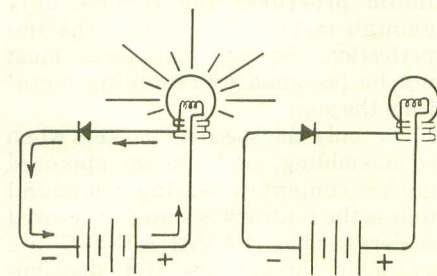

Fig. 2-24—A simple test can be made as shown on a rectifier to show which direction current can flow. Wires should be connected to rectifier so that current is allowed to pass as shown by arrows in wiring diagrams.

**OIL-FUEL RATIO.** Some engines are lubricated by oil that is mixed with the fuel. It is important that the manufacturer's recommended oil to fuel ratio be closely followed. Excessive oil will

cause low power, plug fouling and excessive carbon build-up. Insufficient amount of oil will result in inadequate lubrication and rapid internal damage. The recommended ratios and type of oil are listed in LUBRICATION paragraph of each MAINTENANCE section. Oil should be mixed with gasoline in a separate container before it is poured into the fuel tank. The following table may be useful in mixing the correct ratio.

RATIO	Oil	Gasoline
1:14	½ Pint	.88 Gallon
1:15	½ Pint	.94 Gallon
1:16	½ Pint	1.0 Gallon
1:20	½ Pint	1.25 Gallons
1:24	½ Pint	1.5 Gallons
1:25	½ Pint	1.56 Gallons
1:50	½ Pint	3.13 Gallons

**OIL PUMP ADJUSTMENT.** Some models are equipped with a separate oil tank and pump for lubricating the engine. It is important that the oil pump is properly adjusted to provide the correct amount of oil. If the pump does not deliver the correct amount of oil, the engine may be damaged. Refer to the appropriate engine section for adjustment procedure. It is recommended that adjustment be checked periodically to make sure that oil delivery is correct. Wear and/or control cable stretch will decrease the amount of oil delivered.

**CLUTCH CONTROL**

Clutch cable and/or control linkage is usually provided with adjustments to compensate for some stretch in cable and small amount of clutch plate wear. Clutch linkage should not prevent clutch from completely engaging and when the control is actuated, clutch should not drag. Refer to appropriate section for adjustment procedure and requirements of each model.

**REPAIRS**

Because of the close tolerance of the interior parts, cleanliness is of utmost importance. It is suggested that the exterior of the engine and all nearby areas be absolutely clean before any repair is started. Manufacturer's recommended torque values for tightening screw fasteners should be followed closely. The soft threads in aluminum castings are often damaged by carelessness in over-tightening fasteners or in attempting to loosen or remove seized fasteners.

**DISASSEMBLY AND ASSEMBLY**

When removing the cylinder head, loosen the screws evenly in a diagonal pattern to prevent warpage. After cylinder head is removed, carefully check for distortion using a lapping block or similar flat area.

Two or more identical pistons, rings, connecting rods and bearings may be used, but parts should never be interchanged when reassembling. As parts are removed, they should all be marked to identify the correct position. All

wearing parts seat to the mating parts during operation. If parts are mixed during reassembly, a new wear pattern is established and early failure may result.

A given amount of heat applied to aluminum or magnesium will cause it to expand a greater amount than will steel under similar conditions. Because of the different expansion characteristics, heat is usually recommended for easy installation of bearings, pins, etc., in aluminum or magnesium castings. Sometimes, heat can be used to free parts that are seized or where an interference fit is used. Heat, therefore, becomes a service tool and the application of heat, one of the required service techniques. An open flame is not usually advised because it destroys the paint and other protective coatings and because a uniform and controlled temperature with open flame is difficult to obtain. Methods commonly used for heating are: 1. In oil or water, 2. An electric oven or Kiln, 3. With a hot air

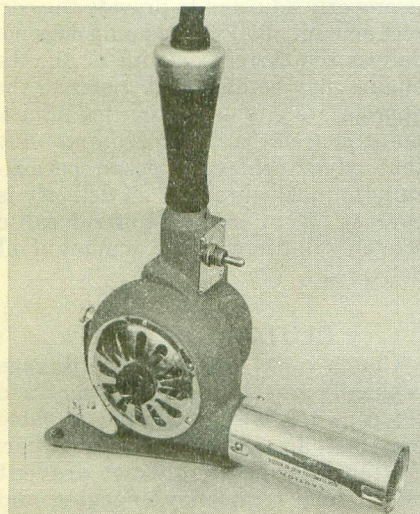

Fig. 2-25—The heat gun shown above has a built in fan. This heat gun and the one shown in Fig. 2-25A are available from Master Appliance Corp., 1745 Flett Ave., Racine, Wis. 53403.

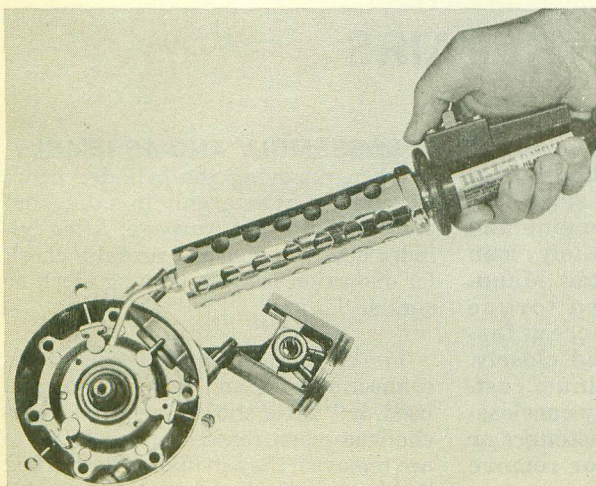

Fig. 2-25A—The heat gun shown uses compressed air from an outside source. The air is electrically heated and temperature is varied (up to 1000° F.) by controlling air pressure.

gun. The use of hot water or oil gives a fairly accurate temperature control but is somewhat limited as to the size and type of part that can be handled. The hot air gun has advantages of control and portability. Two types of hot air guns are shown in Figs. 2-25 and 2-25A. Thermal crayons are available which can be used to determine the temperature of a heated part. These crayons melt when the part reaches specified temperature, and a number of crayons for different temperatures are available. Temperature indicating crayons are usually available at welding equipment supply houses.

The crankcase and combustion chambers must be sealed against pressure, vacuum and oil leakage. To assure a perfect seal, nicks, scratches and warpage are to be avoided, especially where no gasket is used. Slight imperfections can be removed by using a fine-grit sand-paper. Flat surfaces can be lapped by using a surface plate or a smooth piece of plate glass, and a sheet of fine sandpaper or lapping compound. Use a figure-eight motion with minimum pressure, and remove only enough metal to eliminate the imperfection. Bearing clearances must not be lessened by removing metal from the joint.

Use only the specified gaskets when re-assembling, and use an approved gasket cement or sealing compound unless the contrary is stated. Approved sealers such as "YAMAHA BOND" are available through the U.S. distributors. A different type sealer is usually suggested for use with gaskets than without gasket. All friction surfaces, including bearings and seals, should be coated with oil before assembling.

It is desirable to lock some threaded parts when assembling, using a product such as "Loctite". Some locations suggested for using "Loctite" are cylinder studs, bearing retainer plates,

shift stops, suspension components attached to frame, etc.

## REPAIRING DAMAGED THREADS

Special techniques must be developed in repair of engines of aluminum alloy or magnesium alloy construction. Soft threads in aluminum or magnesium castings are often damaged by carelessness in over-tightening fasteners or in attempting to loosen or remove seized fasteners. Manufacturer's recommended torque values for tightening screw fasteners should be followed closely.

Damaged threads in castings can be renewed by use of thread repair kits which are recommended by a number of manufacturers. Use of thread repair kits is not difficult, but instructions must be carefully followed. Refer to Figs. 2-26 through 2-28 which illus-

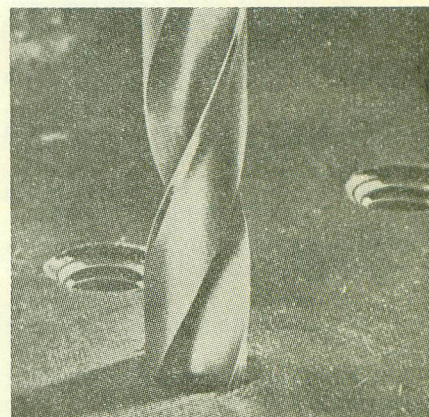

Fig. 2-26—First step in repairing damaged threads is to drill out old threads using exact size drill recommended in instructions provided with thread repair kit. Drill all the way through an open hole or all the way to bottom of blind hole, making sure hole is straight and that centerline of hole is not moved in drilling process. (Series of photos provided by Heli-Coil Corp., Danbury, Conn.)

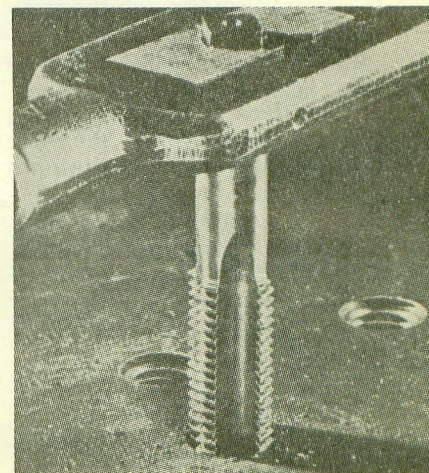

Fig. 2-27—Special drill taps are provided in thread repair kit for threading drilled hole to correct size for outside of thread insert. A standard tap cannot be used.

trate the use of Heli-Coil thread repair kits that are manufactured by the Heli-Coil Corporation, Danbury, Connecticut.

Heli-Coil thread repair kits are available through the parts departments of most engine and equipment manufacturers; the thread inserts are available in most of the common thread sizes and types.

## FASTENER THREADS

Due to the international manufacturing and usage, servicing will require a knowledge of the different types of fastener threads in current use. The normal precaution of making sure threads match before applying force to the fastener must be followed. Due to recent changes in some thread standards, "eyeballing" different fasteners to match threads is virtually impossible and the fasteners must be mated more than one or two turns to detect a difference. A trial fit should always be used when there is any doubt as to threads matching.

Currently, three thread systems are the basis for threaded parts manufactured internationally. They are: the Inch-Thread System, the Whitworth Thread System and the Metric Thread System. The Whitworth Thread System is used mainly in Britain. The Inch Thread System is found in countries using the English system of measurement and has been used in a relatively unchanged state for a long period of time. The Metric Thread System has, however, undergone recent changes which should be noted.

Even though the Metric Thread System is based on the metric system of measurement, standards as to thread pitch, depth and diameter have not

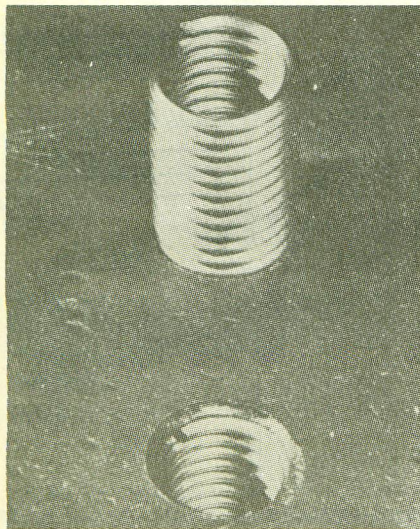

Fig. 2-28—A thread insert and a completed repair are shown above. Special tools are provided in thread repair kit for installation of thread insert.

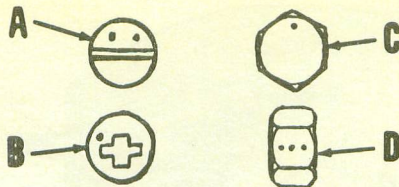

Fig. 2-28A—Marks used by one manufacturer to identify fasteners having ISO Threads. Small dots represent punch or die marks. Slotted screw and set screw marks are shown at (A), Phillips head screw marks at (B), bolt head at (C) and side view of nut at (D).

been internationally consistent. In an effort towards standardization of the Metric Thread System, the major manufacturing countries of the world have agreed to follow the thread standards set-up by the International Standardization Organization (ISO). In the future, fasteners of the same size having ISO metric threads will be interchangeable regardless of manufacturing origin. Identification of ISO fasteners may be different between manufacturers, but some identifying marks are similar and one manufacturer's identifying marks are shown in Fig. 2-28A. In addition to thread changes, some bolt head sizes have been changed. Be sure the tool fits the bolt head.

## PISTON, RINGS, PIN AND CYLINDER

When servicing pistons, rings and cylinders, it is important that all recommended tolerances be closely observed. Parts that are damaged should be carefully examined to determine the cause. A piston damaged as shown in Fig. 2-29 is obviously not a result of normal wear and if the cause is not corrected, new parts may be similarly damaged in a short time. On this particular piston, the skirt is not scored and the first glance will show melted aluminum which has covered the ring on one side. The melted spot (D) on top

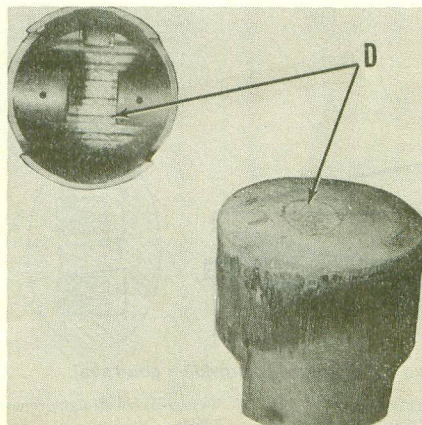

Fig. 2-29—If parts are excessively damaged, cause should be determined and corrected before returning motor to service.

and below piston crown is conclusive proof of detonation damage and the cause must be corrected during overhaul or the same failure can be expected to recur.

If pistons are scuffed or scored, look for metal transfer to cylinder walls. Metal transfer and score marks must be removed from cylinder walls with a hone. Chrome plated cylinder bores should not be honed.

Full strength muriatic acid can be used to remove aluminum deposits from a cast iron cylinder bore. Muriatic acid can be purchased in a drug store. It is also used as a soldering acid, although the supply kept in most radiator shops has usually been cut (diluted) with zinc. Use acid carefully, it can cause painful burns if spilled on the skin and the fumes are toxic. It is most easily used by carefully transferring a small amount to a plastic squeeze bottle, or to another small container and applying with a cotton swab. DO NOT allow the acid to spill or run onto aluminum portions of the cylinder, it will rapidly attack and dissolve the metal. Do not use the acid on a chrome bore. When applied to aluminum deposits, the acid will immediately start to boil and foam. When the action stops the aluminum has been dissolved or the acid is diluted; wipe the area with an old rag or towel which can be discarded. If deposits remain, repeat the process. Flush the area with water when aluminum is removed. Water will dilute the acid and can be used to stop the action if desired, or if acid runs off onto aluminum portion of cylinder, is accidentally spilled, etc. Immediately coat treated portion of cylinder with oil, as the acid makes the cast iron especially susceptible to rust.

A rule of thumb says scuffing or scoring of piston above the piston pin is due to overheating. Damage below the pin is more likely due to insufficient lubrication or improper fit. Overheating may be caused by a lean mixture, overloading, a damaged cooling fan or fins, air leaks in carburetor mounting gasket or manifold, blow-by (stuck or broken rings) as well as carbon build-up.

Before installing new piston rings, check ring end gap as follows: Position the ring near the bottom of cylinder bore. The piston should be used to slide the ring in cylinder to locate ring squarely in bore. Measure the gap between end of ring using a feeler gage as shown in Fig. 2-30. Slide the ring down in the cylinder to the area of transfer and exhaust ports and again measure gap. Rings may break if end gap is too tight at any point; but, will not seal

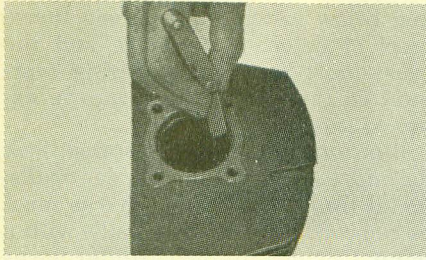

Fig. 2-30—Gap between ends of ring should be within recommended limits.

properly if gap is too wide. Variation in gap indicates cylinder wear (usually near the ports and at top of ring travel.

Ring grooves in the piston should be carefully cleaned and examined. Use caution when cleaning to prevent damage to piston. Grooves for Dykes (L rings), Keystone (Both sides angled) and Half Keystone rings are especially easily damaged. Carelessness can result in poor performance and possibly extensive internal engine damage. Refer to Fig. 2-31. When installing rings on piston, expand only far enough to slip over the piston and **do not twist rings**. After installing rings on piston, use feeler gage to measure ring side clearance in groove as shown in Fig. 2-32. Excessive side clearance will prevent an effective seal and may cause rings to break.

On models with cast iron cylinder or cylinder liner, cylinder bore should be honed to remove glaze from cylinder walls before installing new piston rings. Ridge at top and bottom of ring travel should be removed by honing. If ridge is not removed, new rings may catch enough to bend the ring lands as

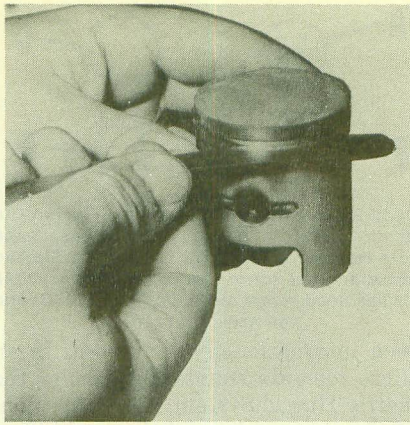

Fig. 2-32—Ring side clearance in groove should be measured with gage as shown. Clearance should be within recommended limits and the same all the way around piston.

shown at (G—Fig.2-31). The finished cylinder should have light cross-hatch pattern as shown in Fig. 2-33. After honing, wash cylinder assembly with soap and water to remove all traces of abrasive. After cylinder is dry, swab cylinder bore with oil making sure that it is absolutely clean.

NOTE: On models with chrome plated aluminum cylinder bore, the cylinder should not be honed or rebored to an oversize. Chrome plated piston rings should not be installed in chrome cylinder bore.

Some manufacturers have oversize piston and ring sets available for use in repairing engines in which the cylinder bore is excessively worn and standard size piston and rings cannot be used. If care and approved procedures are used in oversizing the cylinder bore, installation of an oversize piston and ring set

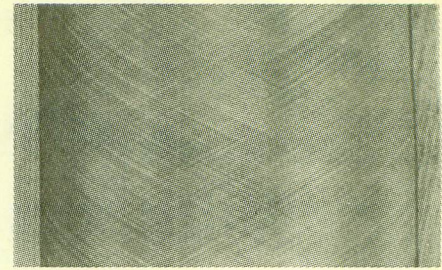

Fig. 2-33—A cross-hatch pattern as shown should be obtained by moving hone up and down cylinder bore as it is being turned by slow speed electric drill.

should result in a highly satisfactory overhaul.

The cylinder bore may be oversized by using either a boring bar or a hone; however, if a boring bar is used it is usually recommended the cylinder bore be finished with a hone. Refer to Fig. 2-33. Before attempting to rebore or hone the cylinder to oversize, carefully measure the cylinder bore to be sure that new, standard size piston and rings will not fit within tolerance. Also, it may be possible that the cylinder is excessively worn or damaged and that reboring or honing to largest oversize will not clean up the worn or scored surface.

Some manufacturers recommend that after boring a cylinder to an oversize, the top and bottom edges of the ports in the cylinder wall be rounded (or beveled) to prevent the rings from catching on sharp port edges. Fig. 2-34 shows typical port cross section with area to be removed shown enlarged at inset.

When assembling piston to connecting rod, observe special precautions outlined in the individual repair sections. The top of the piston is usually marked with an arrow for cor-

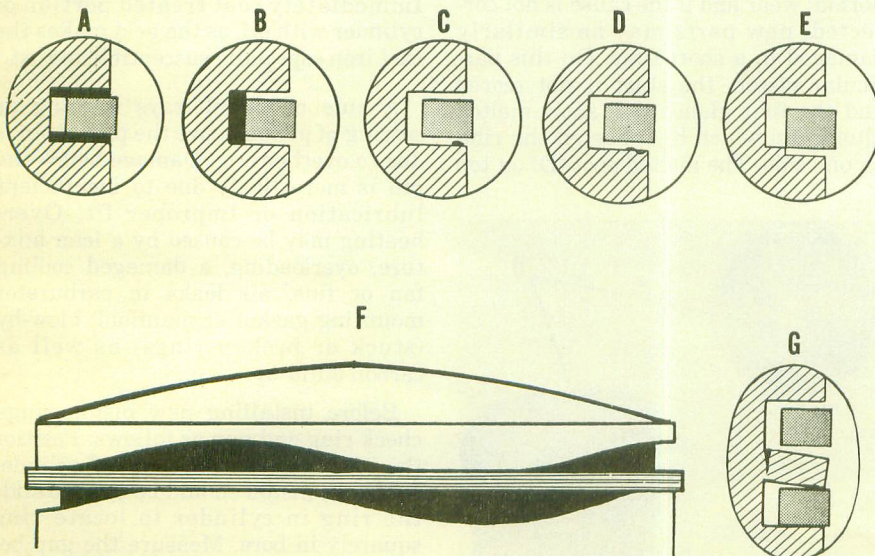

Fig. 2-31—Piston ring grooves must be clean and not damaged to provide a good seal.

- A. Carbon on sides of groove may cause ring to stick in groove.
- B. Carbon on bottom (back) of groove may prevent rings from compressing.

- C & D. Small pieces of carbon (C) or nicks (D) in groove will prevent a good seal.
- E. If groove is worn as shown, renew the piston.

- F. If groove is not straight, renew piston.
- G. Renew piston if ring land is bent.

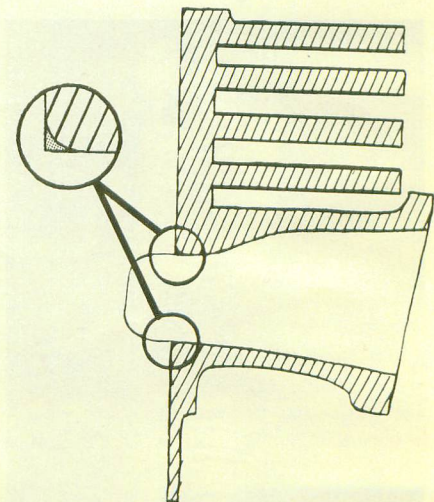

Fig. 2-34—Manufacturers of some two stroke cycle engines recommend that top and bottom edges of ports be chamfered (as shown in the insert) after reboring to prevent piston rings from catching on the sharp edges of ports.

## FUNDAMENTALS

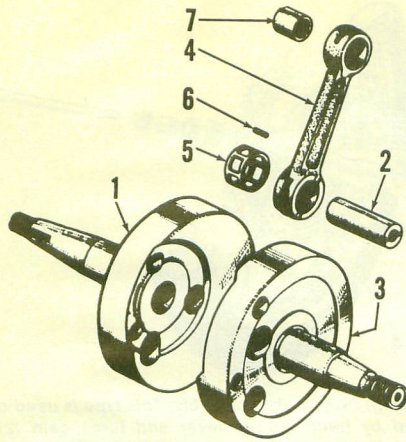

Fig. 2-35—Exploded view of typical press together crankshaft assembly. Many manufacturers have preassembled complete units available as service part.

rect assembly. In addition to positioning ring end gaps so that ends will not catch in ports, the piston pin bore in piston is usually off center. If piston is incorrectly installed, the piston skirt may be broken. Lubricate piston pin bearing (or bushing), piston, rings and cylinder before assembling.

### CONNECTING ROD AND CRANKSHAFT

Many of the crankshafts are pressed together and are composed of parts shown in Fig. 2-35. To remove the connecting rod from these units, it is usually necessary to support one of the crankshaft counterweights and press crankpin out. When reassembling, it is necessary to accurately align the crankshaft assembly using a dial indicator and "V" blocks or lathe as shown in Fig. 2-36 or Fig. 2-37. Specification for maximum eccentricity and suggested method of measuring is given, in appropriate REPAIR section for each model.

NOTE: The crankshaft should be disassembled only if the required tools are available to check and align the reassembled crankshaft. On some models, repair parts are not available and the complete assembly is renewed on an exchange basis.

### CRANKCASE AND GEARBOX

Most crankcases are composed of two halves which must be separated to remove internal parts. Usually dowel pins are used to align the two halves. The crankshaft bearings, dowel pins, transmission bearings and sealer all hold the two halves together and it is sometimes difficult to separate. **Extreme caution should be exercised when separating halves.** The mating surfaces will be difficult to seal if nicked or scarred. The crankshaft may be knocked out of alignment if main bearings are dislodged by pounding on

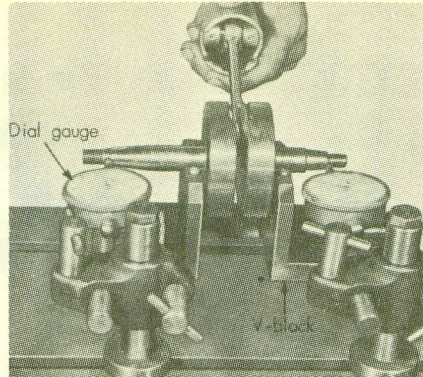

Fig. 2-36—Method of measuring crankshaft run-out (eccentricity) using "V" blocks and dial indicators is shown above.

end of crankshaft. Some manufacturers provide special tools for removing (and installing) crankshaft and main bearings from crankcase bores.

## FRAME AND COMPONENTS

### BRAKES

Front and rear brake action should be checked each time before the motorcycle is ridden. The front brake hand lever should **never** be compressed against hand grip even with brake fully applied. Normal **minimum** suggested clearance (as shown in Fig. 2-39) is approximately  $\frac{7}{8}$  inch with front brake locked. Adjustment is accomplished at cable adjusters shown in Fig. 2-40 and Fig. 2-41 or at hand lever end of cable. Rear brake pedal should be compressed approximately  $\frac{7}{8}$  inch (as

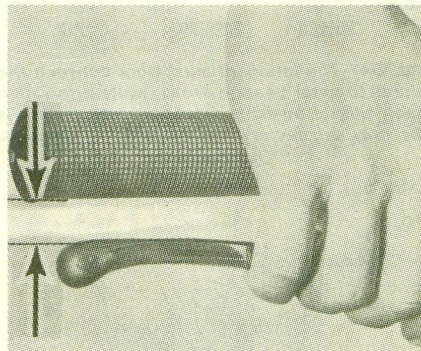

Fig. 2-39—The front brake hand lever should never contact the hand grip.

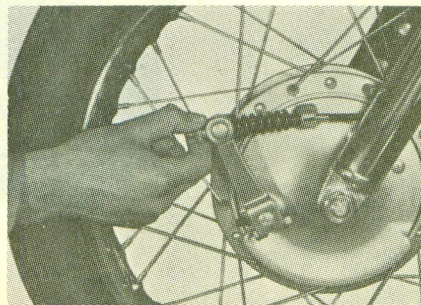

Fig. 2-40—Some models are provided with an adjustment nut as shown at end of front brake cable.

## Frame and Components

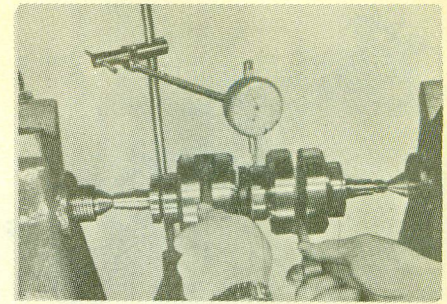

Fig. 2-37—Method of measuring eccentricity with crankshaft mounted between lathe centers using a dial indicator.

During reassembly of the transmission assembly, each gear selection should be engaged and crankshaft (or transmission shaft) rotated to make certain that reassembly is correct **BEFORE** completing the reassembly and installation.

shown in Fig. 2-42) with rear brake locked. Adjustment is normally accomplished as shown in Fig. 2-41 or 2-43.

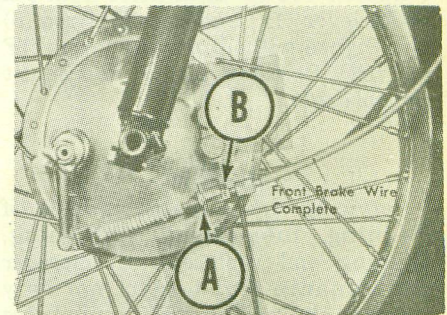

Fig. 2-41—Some front and rear brakes are adjusted at cable guides shown at (B) after locknut (A) is loosened.

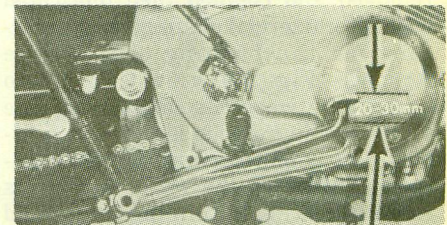

Fig. 2-42—Rear brake pedal should normally lock rear wheel when compressed approximately  $\frac{7}{8}$  inch.

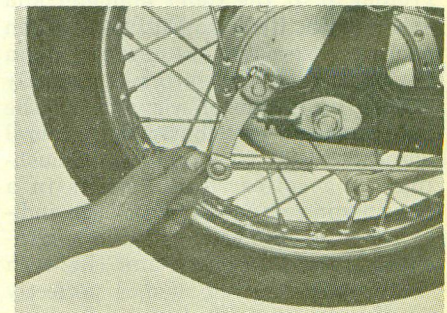

Fig. 2-43—An adjuster nut is provided at end of rear brake rod on some models as shown. Adjustment of other models may be similar to front wheel shown in Fig. 2-41.

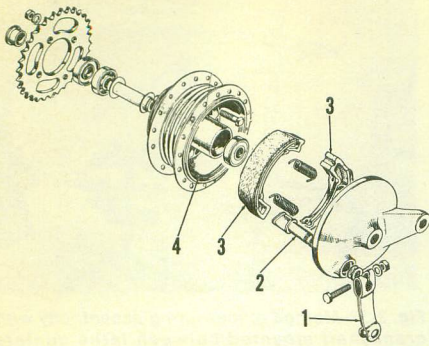

Fig. 2-44—Exploded view of simple rear brake assembly. Front brake may be similar. Lever (1) is actuated by controls and turns cam (2) expanding shoes (3) against drum (4).

When adjusting brakes, setting should not be so tight that wheels are hard to turn with brakes released. Typical exploded views of brake assemblies are shown in Figs. 2-44, 2-45 and 2-46.

On dual cam brakes, rod (5—Fig. 2-45) should be adjusted as follows: Disconnect brake cable from lever (1F) and remove pin (6). Adjust length of connector rod (5) until holes from pin (6) in lever (1F) and connector rod (5) are aligned without moving levers (1F and 1R). Reinstall pin (6) and adjust control cable.

**CHAIN**

Servicing drive chains consists of cleaning, lubricating, tightening, aligning and replacement. Improper maintenance and neglect not only shortens chain life but also contributes to sprocket wear.

The rear chain should periodically be removed and cleaned then lubricated with a commercial chain grease. Lubricant for the bushing area (White Arrows—Fig. 2-47) must work into bushing between the close fitting side plates and immersion is the most satisfactory way of assuring complete lubrication. Most of the chain lubricants require heating to thin the grease and allow the lubricant to enter all surfaces of the chain.

Sprocket tooth profile is precisely ground to fit the roller diameter and chain pitch, Refer to Fig. 2-48. When chain and sprocket are new, the chain moves around the sprocket smoothly with a minimum of friction, and the load is evenly distributed over several sprocket teeth. Wear on pins and bushings of a roller chain results in a lengthening or "stretch" of each individual chain pitch as well as a lengthening of the complete chain. The worn chain, therefore, no longer perfectly fits the sprocket. Each roller contacts the sprocket tooth higher up on the bearing area (C) and that tooth bears the total load until the next tooth and

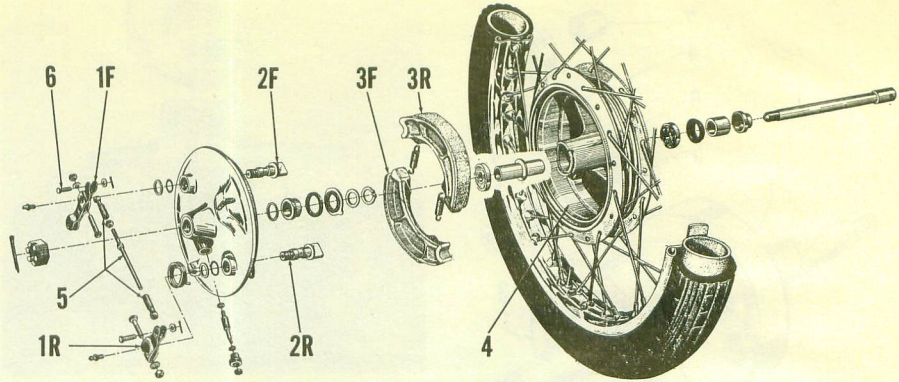

Fig. 2-45—Exploded view of dual cam (full self-energizing) front brake assembly. This type is used on rear on some models. Front lever (1F) is actuated by hand control lever and turns cam (2F) expanding brake shoe (3F). Rod (5) connects the two levers together so that rotation of lever (1F) will also rotate lever (1R).

roller make contact. Chain wear will therefore quickly result in increased sprocket wear.

As a rule of thumb, the chain should be inspected periodically and renewed whenever chain stretch exceeds 2% (or 1/4-inch per foot). Check sprockets carefully for wear if chain wear is substantially greater than 2%, and renew

sprockets if in doubt. Sprocket wear usually shows up as a hooked tooth profile. A good test is to fit the sprocket to a new chain. Wear on sides of sprocket indicates misalignment. If sprockets must be renewed because of wear, always renew the chain. Early failure

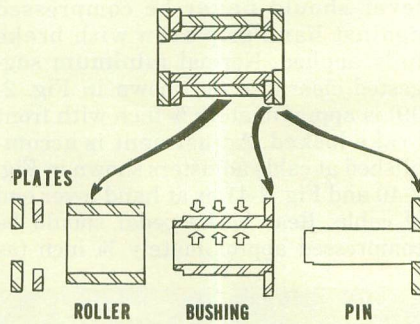

Fig. 2-47—The lubricant must work between the plates to enter bearing areas (white arrows) on each side of bushing. Occasional immersion is the only satisfactory way of assuring complete lubrication.

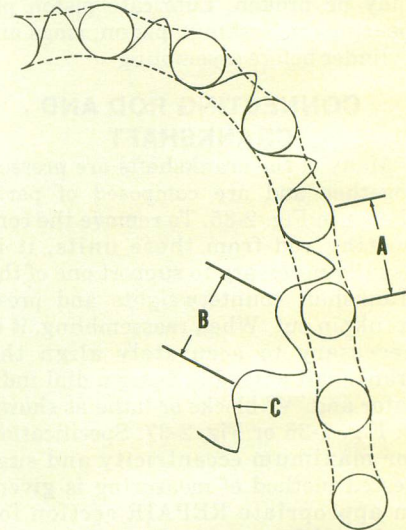

Fig. 2-48—Chain pitch (A) must exactly equal sprocket pitch (B) to prevent excessive wear on bearing edge of sprocket tooth (C). Refer to text.

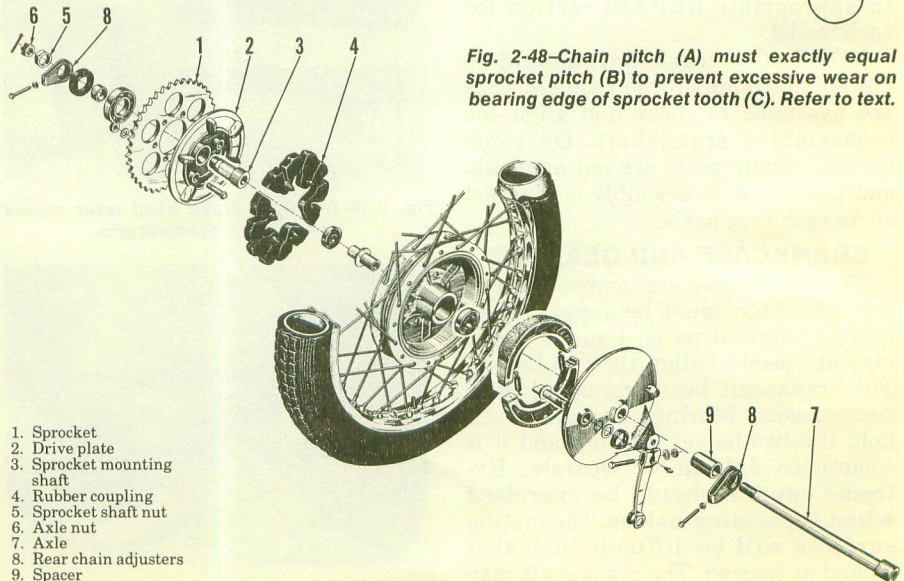
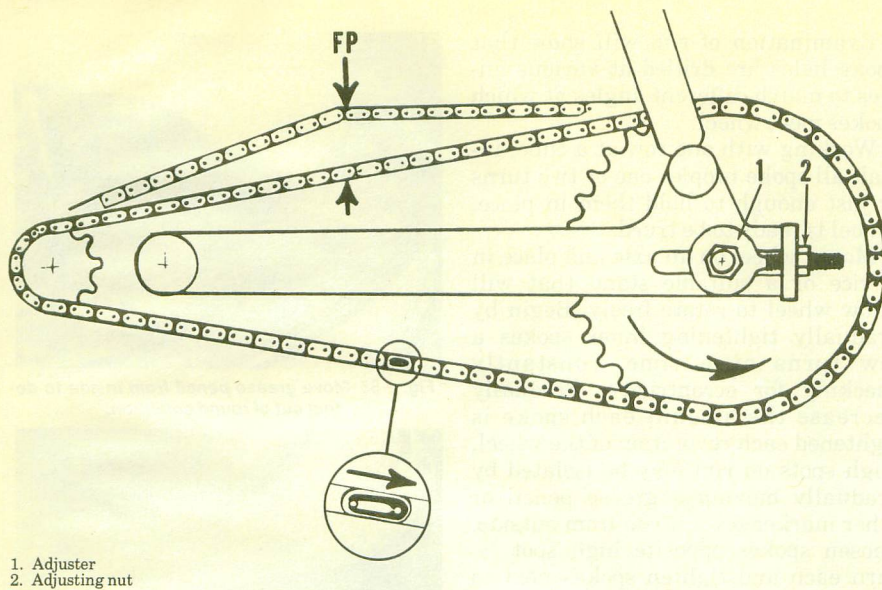

Fig. 2-46—On some models, the rear wheel can be removed without disturbing rear sprocket (1). Lugs on drive plate (2) fit into coupling (4) in wheel.

## FUNDAMENTALS



1. Adjuster
2. Adjusting nut

Fig. 2-49—The recommended rear chain free play (FP) is listed in the table preceding each maintenance section. Inset shows correct master link installation.

can be expected if a new chain is mated with worn sprockets or new sprockets with a worn chain.

The rear chain is usually tightened by an adjuster similar to the one shown at (1—Fig. 2-49) located at each end of the rear axle. The adjuster located on the side of the chain provides most of the chain tightening, however every time the chain free play is adjusted, the sprocket alignment must also be checked. Improper alignment will subject the chain to side load and rapid wear and sprocket will show wear on sides of teeth. Free play should be measured midway between sprockets as shown at (FP—Fig. 2-49). Recommended rear chain free play is listed in the table preceding MAINTENANCE section of each model. Adjusters on both sides of axle should be tightened to provide correct free play and align sprockets. Refer to Fig. 2-51.

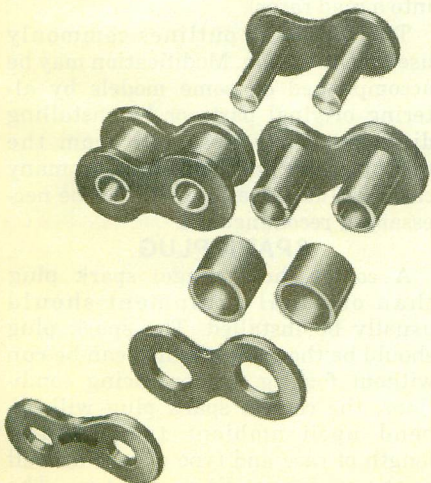

Fig. 2-50—Exploded view of typical single row drive chain.

Adjustment procedure for primary chain on models so equipped is outlined in MAINTENANCE section for that model.

### WIRE WHEELS

Particular attention should be applied to the maintenance of wire wheels. Spokes should be checked for tightness periodically and any missing, bent or broken spokes renewed. The condition of the wheel hub should also be noted. The load of the motorcycle and rider is taken by the top spokes as the wheel revolves. Each spoke is designed to accept a part of the load, but as spokes are damaged, an unequal amount of the load is carried by other spokes which may eventually cause wheel failure.

Spoke tightness should be checked occasionally by gently hitting a metal object, such as a screwdriver, against each spoke. If the spokes are tightened evenly, each spoke, when hit, will produce a sound with a pitch approximately the same as the rest of the spokes. Tighten spokes with a spoke wrench until the same approximate pitch is heard on all spokes.

Single spokes may be renewed without dismantling wheel if rim and hub are not damaged. Release a small amount of air but do not flatten tire. Remove hooked end of spoke from hub, cut spoke to remove it if not already broken. Unscrew spoke from nipple being careful not to force nipple into rim. Insert replacement spoke through hub and attach to nipple. Spoke may be slightly bent on installation but should pull straight when tightened. New spoke should be checked for tightness after a few hours of run in time.

Most wheels are equipped with two different types of spokes, commonly

## Frame and Components

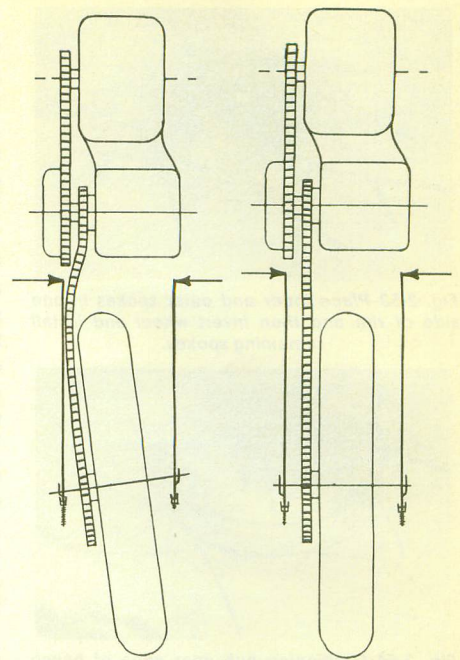

Fig. 2-51—The rear chain should be adjusted to provide correct chain alignment as shown in the right view.

called inner and outer spokes (Fig. 2—52). Outer spokes (A) tend to have more of a right angle bend while inner spokes (B) have a smaller angle bend. Inner and outer spokes are identical on some wheels but on units where the spokes are different they must be installed correctly.

If rim is bent or hub is broken, it will be necessary to remove and disassemble wheel. Before dismantling wheel, pay special attention to pattern of spoke lacing. There are several ways to lace wheels and sometimes wheels will be laced two different ways on the same motorcycle. When dismantling wheel, segregate inner and outer spokes and place spoke nipples in a container of light oil or solvent to aid reassembly.

Place hub on work bench and install outer, then inner spokes of top rim on

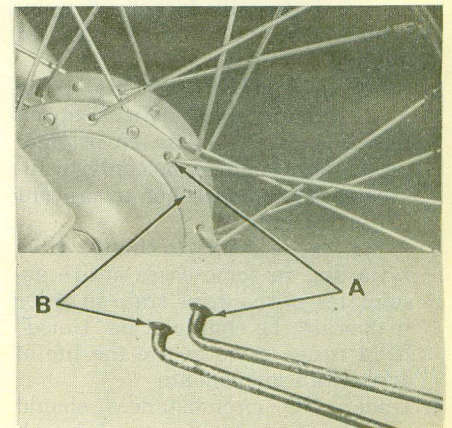

Fig. 2-52—Inner spokes (B) and outer spokes (A) may have different radius bend at head.

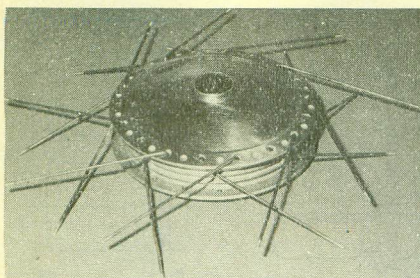

Fig. 2-53—Place inner and outer spokes in one side of rim and then invert wheel and install remaining spokes.

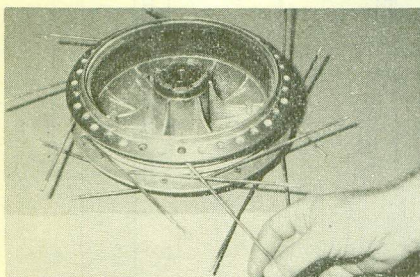

Fig. 2-54—Positioning hub near edge of bench will ease spoke installation.

hub (Fig. 2—53). Carefully invert hub and install remaining spokes. Placing hub close to edge of work bench will ease installation (Fig. 2—54). After installing all spokes and placing them in the approximate pattern they will be in, place wheel rim in position.

Examination of rim will show that spoke holes are drilled at various angles to match different angles at which spokes meet wheel.

Working with one row at a time, install all spoke nipples one or two turns or just enough to hold them in place. Wheel is ready to be trued.

Mount wheel on an axle and place in a vice or a suitable stand that will allow wheel to rotate freely. Begin by gradually tightening inner spokes a few turns at a time, constantly checking for eccentricity. Gradually decrease the amount each spoke is tightened each revolution of the wheel. High spots on rim may be isolated by gradually moving a grease pencil or other marker toward rim from outside. Loosen spokes opposite high spot ½-turn each and tighten spokes next to high spot ½ turn each. Wipe away mark and recheck.

When all eccentricity is removed, gradually tighten outer spokes in the same manner. Bring marker in from side to check for side-to-side play. Loosen spokes pulling rim off center and tighten adjacent spokes to help bring rim toward center. When wheel is completely aligned strike each spoke with a small metal object to make certain that none have been left loose.

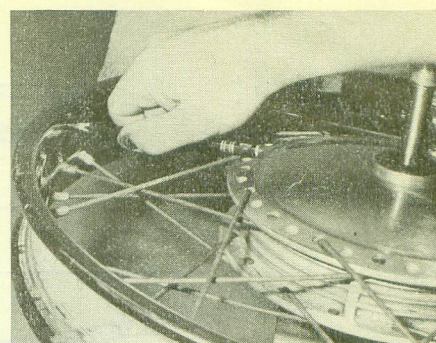

Fig. 2-55—Move grease pencil from inside to detect out of round condition.

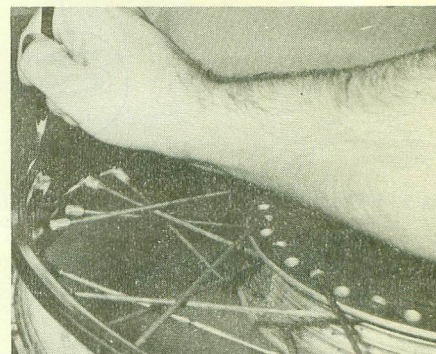

Fig. 2-56—Move grease pencil from side of rim to detect side to side play.

Any portion of spoke protruding past nipple into rim should be ground off to prevent tire damage.

## SPEED TUNING

Procedures and specifications for modifying individual engines are included in some of the engine service sections. These modifications may be accomplished with varying degrees of success. Before any alterations are started, several things must be considered.

1. The life of an original production engine is usually longer (if maintained properly) than a modified engine.
2. Clearances and settings for all parts must be maintained more closely on modified engines than on original production engines, not only to increase performance but to prevent extensive damage.
3. It may be necessary to change drive ratio and in some cases entire assemblies in the drive train in order to operate the engine at its "tuned" RPM range or to insure the life of drive train components.
4. Under NO circumstances should work be started without a thorough knowledge of what and why it is being done.

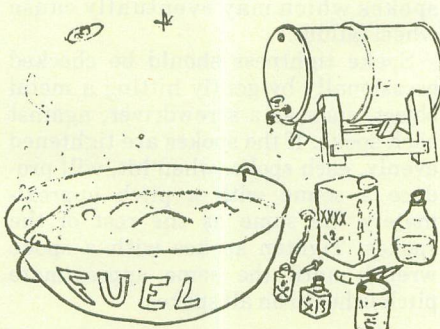

Fig. 3-1—Some fuel mixtures can be used successfully, but be careful when experimenting.

5. Make certain that the correct tools are used. Port modification, etc. may result in less power and/or destruction of an engine if improperly or carelessly done.
6. Any modification will void manufacturer's warranty.

The data included in the individual engine service sections is generally not the ultimate in modifications and is not intended to be. The changes listed are made available only after the manufacturer has completed extensive tests

and is convinced the modifications are safe and practical.

Many motorcycles can be modified to increase performance for the type of riding for which it was designed; however, it is more difficult to change its intended use (such as a trials model into a road racer).

The following outlines commonly used modification. Modification may be accomplished on some models by altering original parts or by installing different parts available from the manufacturer or other source. In many cases, all modifications will not be necessary or recommended.

### SPARK PLUG

A colder (heat range) spark plug than original equipment should usually be installed. The spark plug should be the coldest which can be run without fouling. Under racing conditions, the correct spark plug will depend upon ambient temperature, length of race and type of race as well as the engine condition and type. The correct heat range may be too cold for operation until engine has been started

## FUNDAMENTALS

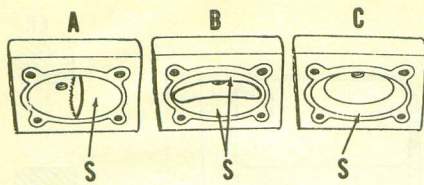

Fig. 3-2—Drawing showing typical cylinder heads. Type "A" has squish area (S) only on one side. Type "B", sometimes called a trench type head, has squish area (S) on two sides. Type "C" is hemispherical with squish area (S) completely around edge.

and warmed up. If the correct plug for racing conditions fouls before engine reaches normal temperature, use a hotter plug (such as original equipment type) to start and warm up the engine. If the spark plug is too cold, the plug will foul without causing excessive damage; however, the engine may be damaged if plug heat range is too high.

Make certain that the correct reach (thread length) and thread type (SAE or ISO) is selected. In some cases, it may be necessary to install different thickness spark plug gasket or two gaskets in order to have correct heat range and reach. Booster gap spark plugs are not recommended for most racing applications.

### FUEL SYSTEM

The fuel system should receive careful consideration. Make certain that fuel fittings, lines and filters do not restrict fuel flow causing lean mixture at high speed.

If a different carburetor is installed, extreme care should be exercised. It is possible to install a carburetor that is too large on most engines. Some carburetor changes will cause "flat spots" at various RPM, loss of torque (especially at low RPM), hard starting or extensive engine damage from incorrect fuel-air mixture. When selecting a different carburetor, make certain that it is correct for your application. Carburetor and engine manufacturers are usually very helpful.

When adjusting mixture, a slightly rich setting is more desirable than a lean mixture. Check condition of fuel filters and fuel lines if mixture can not be set too rich at high RPM. Air leaks in crankcase will also cause lean mixture, especially at low RPM.

Fuels other than gasoline or additives for use with gasoline should be used with extreme caution. A great many different chemicals will aid performance, but many increase engine temperature and/or require a much richer fuel to air ratio. Sometimes the standard fuel lines will not supply enough volume, drilled passages and jets must be enlarged and some fuels will corrode or otherwise damage fuel

system parts. Several commonly used fuels will not mix with petroleum based oils and some require the use of an ester to mix with a lubricant.

### IGNITION SYSTEM

Various ignition system changes are possible, including total loss battery ignition, capacitor discharge, energy transfer, etc. The system that seems to work for one engine tuner with one make (or model) of engine in one type of race may not be at all satisfactory to another. One thing common to all systems used for racing is that the ignition system must be maintained in much better condition than required for lower speed, lighter load applications.

On most engines, the original production timing will be correct or nearly correct. If ignition timing is to be advanced beyond original setting, begin with the original setting then slowly and carefully experiment with different timing. Excessive spark advance can destroy an engine very quickly.

### CYLINDER HEAD

The cylinder head should usually be modified. The effective compression ratio is determined by displacement when the piston closes the exhaust port, not total displacement when piston is at Bottom Dead Center. If the exhaust port is raised, the effective compression ratio will be lowered and power may decrease if the cylinder head is not changed also. Some cylinder heads are manufactured to be used in combination with the raised exhaust port. If these cylinder heads are used on standard cylinder (with lower exhaust port), the engine may be damaged or power may decrease because of too high compression (preignition).

Many cylinder heads have a squish area (part of the cylinder head is very close to piston at Top Dead Center). The part of the cylinder head closest to piston may be all around the edge of cylinder (C—Fig. 3-2), only one side of cylinder (A) or on two sides (B). The squish area is provided to cause turbulence of the gaseous mixture for more complete burning. It is very important that the original clearance between low part of cylinder head and piston be maintained if the cylinder head is modified. If only the lower surface of cylinder head is milled, the piston will probably hit the cylinder head. If the squish area is also machined, but not enough material was removed (resulting in too little squish clearance), the engine may not run properly because of localized hot spots and/or trapped pockets of the gaseous mixture. Squish area should usually be machined to follow the original contour

## Speed Tuning

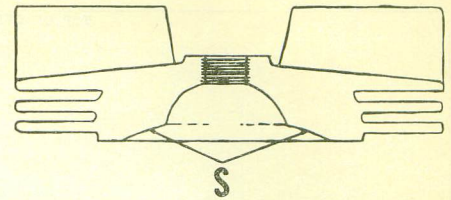

Fig. 3-3—If the cylinder head is milled, the squish area (S) must be changed also. Clearance between piston and squish area should be the same as original.

and clearance. Make certain that squish clearance is continued to the edge of the cylinder bore.

It is not necessary to polish the combustion chamber surface to a mirror finish; however, all sharp edges should be removed to prevent hot spots which might cause pre-ignition.

### CYLINDER

Use extreme caution when modifying the cylinder in any way. The inlet, transfer and exhaust ports and passages are carefully designed and manufactured originally, and even more care should be exercised when changing them. The gases are timed by the vertical location of the ports in cylinder wall. Direction and velocity of flow is controlled by the width of ports and size and shape of the passages. If modification is sloppy or incorrect, power may be less than with original cylinder.

Carefully inspect the removed cylinder. Note the cylinder material and condition of cylinder bore. The three types of cylinders generally used are cast iron, aluminum with iron sleeve and aluminum with hard chrome plating in bore. A worn out or damaged cylinder should not be modified unless it can be repaired. If cast iron or aluminum with cast iron sleeve type cylinder is to be rebored to larger size, the cylinder should be resized before modifying ports. Refer to PISTON paragraphs for fitting piston.

Modification of cylinder made of cast iron or aluminum with cast iron sleeve can be accomplished by using a rotary grinder if carefully done. Work slowly and carefully, using as fine a stone as practical. A stone which is too coarse will have a tendency to work into one area, will be difficult to control and will result in rough irregular shapes. On some models with aluminum cylinder and cast iron sleeve, the cylinder can be heated, old sleeve removed and new chilled sleeve pressed into place. Make certain that all ports and passages are aligned when installing new sleeve.

Aluminum cylinder with hard chrome bore is normally found on higher performance models and extensive modification is not necessary. If any changes are made, be especially

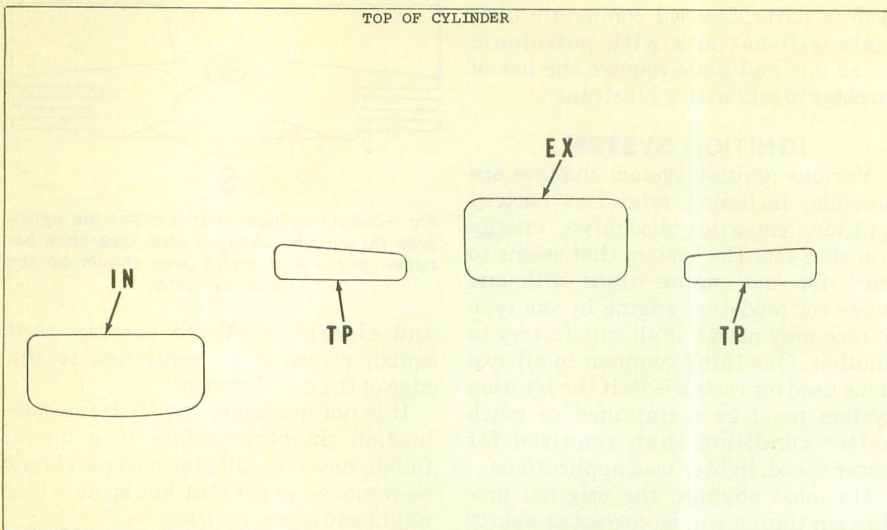

Fig. 3-5—A pattern of the original ports in cylinder should be made before changing any of the openings. Radii of the corners and edges are difficult or impossible to draw in the cylinder without a pattern.

careful or the chrome plating will be ruined and the cylinder will be useless. DO NOT bore or hone aluminum cylinder with hard chrome plated bore. Additional clearance between piston and cylinder can be accomplished by carefully finishing the piston. Refer to PISTON paragraphs for fitting piston to cylinder. If small amounts of material from piston have stuck to chrome cylinder bore, they can be removed by hand sanding. Very carefully sand diagonally as shown in Fig. 3-13. Using #400 or #600 sandpaper with oil or gasoline. Sand only by hand and stop when piston material is removed. DO NOT DAMAGE the chrome plating.

Before any grinding is done, examine original ports and note location, size and shape. Location and shape of ports can be transferred to paper positioned in cylinder bore and gently pressed against all of the port openings and top and bottom edges of cylinder bore. Be sure that paper does not move or an incorrect pattern will result. If carefully done, the removed paper should be marked similar to Fig. 3-5. All suggested radii are difficult (or impossible) to draw in the cylinder and if first

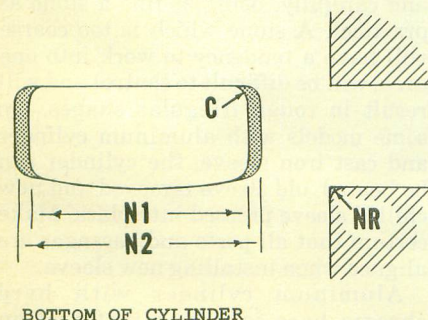

Fig. 3-6—Increasing the width of inlet port will only increase size and will not change timing. The lower edge (NR) should usually be rounded or beveled to prevent piston skirt from catching.

drawn on paper pattern can be more easily transferred to the cylinder.

Changes in port sizes and shapes should be drawn on inside of cylinder bore before grinding. Coat the area where changes are to be made with machinist dye or similar material, then scratch lightly through the coating to show material to be removed. In most cases, a pattern of the modified port will facilitate marking.

The inlet port and exhaust port are usually the easiest to work with and should be done first. On loop scavenged engines, modification to only one of the transfer ports and/or passages (or unequal modification to all transfer ports and passages) will prevent correct balance and possibly direction of the incoming fuel-air mixture. The result is usually reduced power and increased fuel consumption.

The inlet port (IN—Fig. 3-5), on piston ported models, is opened as the piston skirt moves toward the upper part of the cylinder. Advanced inlet timing (open sooner) and increased duration (stays open longer) can be accomplished on most models by cutting part of the piston skirt off. Lowering the bottom edge of port will also advance inlet timing and increase duration and is sometimes recommended. Advancing inlet timing on piston ported engines will also cause the port to close later resulting in less compression in the crankcase. Changing the width (Fig. 3-6) of inlet port only increases size. On most models, the lower edge of inlet port should be rounded slightly (NR) to prevent the piston skirt from catching on edge.

The inlet passage from carburetor to inlet port should be smoothed and in some cases be enlarged. Make certain that carburetor, gaskets, heat shields,

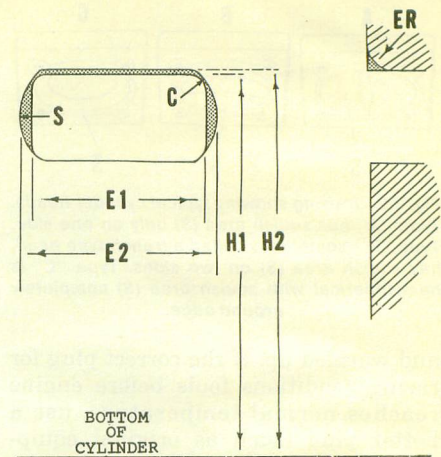

Fig. 3-7—Raising the exhaust port in cylinder will cause port to open sooner. If port modifications are incorrect, rings will probably catch and cause extensive damage. Radius (S) at sides and rounded edge (ER) guide rings back into grooves.

adapters, etc. are all aligned and passage through these parts and into inlet passage is smooth. Any misalignment will cause turbulence and restriction resulting in less power.

The exhaust port (EX—Fig. 3-5) is often raised and enlarged (width increased). Certain precautions must be taken or results will be totally unsatisfactory. Raising the exhaust port will cause it to open sooner and close later. While this is often desirable, raising the port will decrease compression of the fuel-air mixture before ignition, decrease the length of time for burning after top dead center and decrease the length of the power stroke. Within limits and with other modifications, raising the exhaust port can sometimes increase power. The limits suggested by the manufacturer should usually be considered the safe maximum. If width of exhaust port is increased, the piston rings may expand into and catch in the port. On some engines, the exhaust port is bridged to hold the rings, on some the top edge is rounded or beveled (ER—Fig. 3-7) and on some the sides of the ports are tapered or round (S) to guide the ring back into the grooves. Many engines use a combination of ways to hold and guide the rings out of the exhaust port. Extensive damage is sure to result if the rings catch in the exhaust port and the engine will probably not run long enough to determine whether power was increased or not. Width should not be increased beyond suggested limits.

The transfer ports (TP—Fig. 3-5) are usually difficult to reach in order to modify and the transfer passages (usually cast with the cylinder) are even more difficult. Some suggest that the piston be notched (Fig. 3-9) or spacer (S—Fig. 3-10) be installed between cyl-

## FUNDAMENTALS

inder and crankcase as alternate methods of advancing transfer port timing. The method suggested in the individual engine section should be fol-

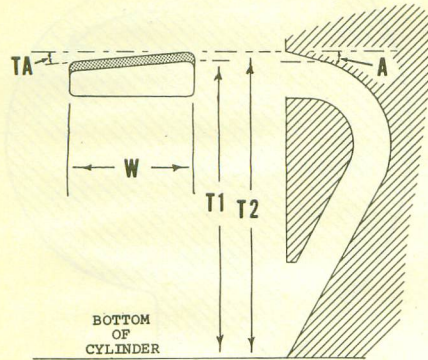

Fig. 3-8—Raising the transfer ports will cause ports to open sooner. Angles of passage (A) and port (TA) direct fuel into cylinder and should be closely maintained.

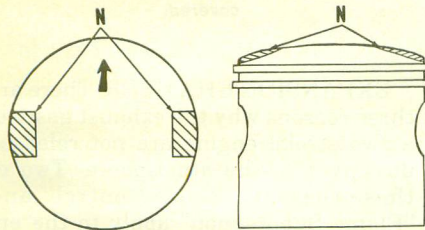

Fig. 3-9—If manufacturer recommends cutting the piston (N) to advance transfer port timing, use extreme care. Depth of cut will weaken piston and possibly damage piston rings.

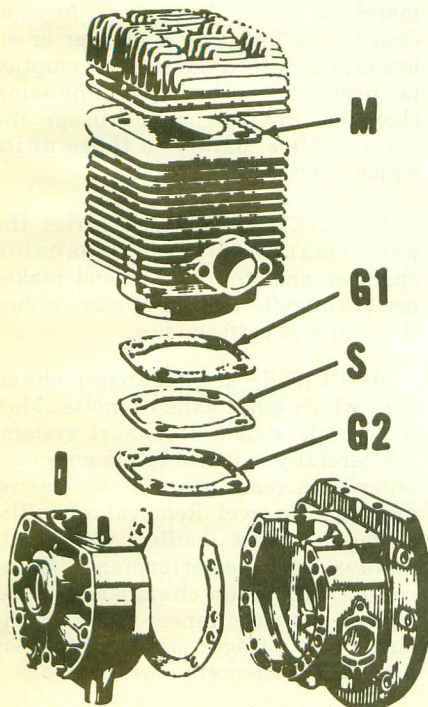

Fig. 3-10—Sometimes a spacer (S) is installed below cylinder to raise the transfer ports. Be sure to note that all ports (inlet and exhaust as well as transfer ports) will be raised. A second gasket (G2) should be used below spacer and combined thickness of spacer (S) and gasket (G2) is the amount that cylinder is raised. The amount that cylinder is raised should be machined from top of cylinder (M).

lowed. If the transfer ports and passages are reshaped; be sure that they are all alike and correct. The angle (A—Fig. 3-8) of the inlet passage and port (TA) determines the direction of the fuel-air charge entering the cylinder; if incorrect, fuel will be wasted and the cylinder will not be cleared of old gases. The transfer passage in crankcase, gasket, cylinder, and sometimes piston skirt, should be matched to provide smooth, nonrestrictive flow. Refer to Fig. 3-11.

Modifications to cylinder such as addition of transfer ports (fifth porting, gully porting, etc.) should usually be discouraged. When performed by an experienced shop, these modifications may increase performance, but should be considered risky.

## PISTON

Special performance pistons, using thin rings, "L" rings, etc. are available from many sources including some of the engine manufacturers. The rings used on high performance pistons are designed to resist fluttering at high engine speeds. If the special pistons

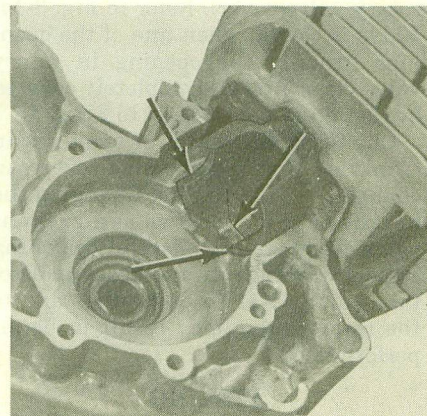

Fig. 3-11—The cylinder should match with crankcase openings. Arrows indicate locations of possible misalignment.

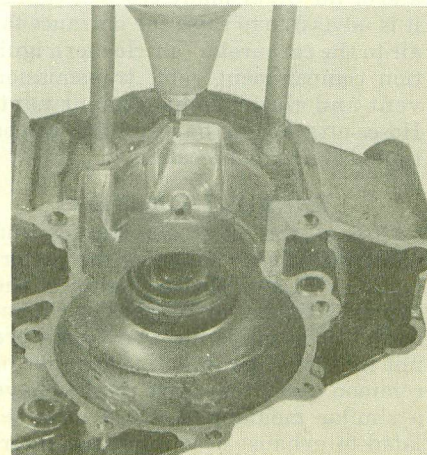

Fig. 3-11A—All bearings should be removed when correcting misalignment of passages. Make certain that all parts are completely cleaned before assembling.

## Speed Tuning

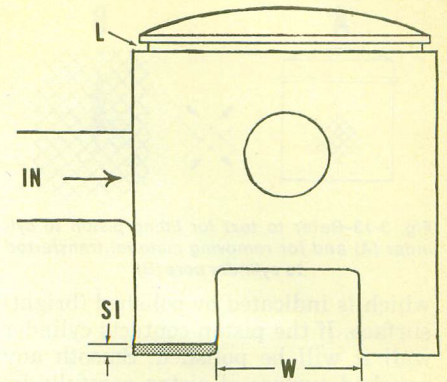

Fig. 3-12—Some pistons designed for high speed operation use an "L" shaped ring. Cutting bottom edge of piston skirt (SI) off will cause inlet port (IN) to open sooner. Slot (W) in lower edge of piston should match with similar openings in cylinder with piston at Bottom Dead Center.

and rings are available, installation is usually advisable.

NOTE: Never install chrome plated rings in chrome plated cylinder bore. Do not install "L" ring and piston in cylinder bore which has been operated with standard type ring unless cylinder is rebored to remove old ridge.

On most engines with piston port inlet, the inlet timing is advanced and inlet duration increased by removing part of the piston skirt (SI—Fig. 3-12) that covers the inlet port. Only a small amount of the lower edge should be removed on most engines. If piston is marked for installation in the cylinder (nearly all are marked), make sure that piston is cut correctly. If the piston has windows (W) in lower edges which align with the lower end of transfer passages, they should not partially block the passages. After cutting the piston, be sure to round off all sharp edges and corners.

Any modifications to piston (welding, drilling holes, etc.) should be considered risky. Some modifications involving these techniques may be successful when accomplished by experienced personnel but should not be attempted without considering the risk.

The piston to cylinder clearance on high performance engines should usually be more than on standard production models. If cylinder material was originally cast iron and was changed to aluminum with hard chrome bore, the clearance when cold may be less.

The piston should be fitted as follows, if new piston and/or cylinder is installed: Run the machine at partial RPM and partial load for a short time (approximately 5 to 10 minutes), then remove cylinder and piston. Check the piston for any localized high spots

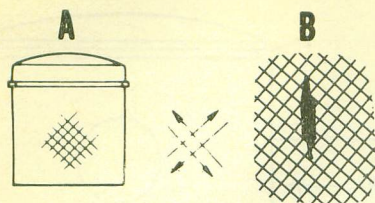

Fig. 3-13—Refer to text for fitting piston to cylinder (A) and for removing material transferred to cylinder bore (B).

which is indicated by polished (bright) surface. If the piston contacts cylinder wall it will be polished. Smooth any polished surface of piston carefully by hand using #400 or #600 sandpaper. Refer to B—Fig. 3-13. Also check the cylinder for deposits of aluminum transferred from the piston. If deposits are present, sand diagonally as shown at (A—Fig. 3-13) very carefully using #400 or #600 sandpaper with oil. Sand only by hand and stop when piston material (aluminum) is removed. Thoroughly clean and reassemble. The machine should be run (gradually increasing RPM and load), disassembled, checked and fitted (sanded) as many times as required to perfectly fit the piston to cylinder. Do not remove too much material from piston at one time. Do not run engine too long, too fast or at too much RPM and load. The preceding is in addition to the normal piston fitting to provide a more controlled break-in, not as a substitute for fitting the piston to cylinder at initial assembly.

Piston damage can be caused by incorrect piston to cylinder clearance, improper lubrication, incorrect ring clearances, incorrect ignition timing, detonation, incorrect fuel-air mixture, pre-ignition, incorrect piston to cylinder head clearance, incorrect shape or size of ports, etc. As many safety precautions as possible should be taken when first running, such as slightly rich fuel-air mixture, slightly rich lubrication, ignition timing not overly advanced, installation of cold plug. As running time increases, the optimum settings can be established.

### ROTARY VALVE

The rotary inlet valve can be modified to provide different opening and closing than standard; however, several precautions should be noted.

Use extreme care when modifying a standard rotary valve. The valve may be weakened and (especially if operated at higher than standard rpm) valve may fly apart causing extensive damage. Some motorcycle manufacturers (and other sources) offer rotary valves with timing (cutaway) different than standard. These high speed rotary valves usually operate more safely than modified standard units.

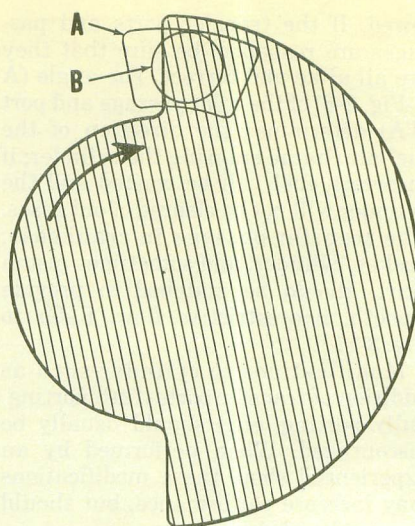

Fig. 3-14—The rotary valve opening begins when passage in crankcase (A) and passage in rotary valve cover (B) are both uncovered. Round port openings such as shown at (B) cause more gradual opening and closing than square port as shown at (A).

The rotary valve is sandwiched between the crankcase and a cover. Inlet opens when rotary valve begins to uncover **both** openings (in crankcase and rotary valve cover). Refer to Fig. 3-14. Valve is closed, when **one** of the openings (usually the opening in rotary valve cover first) is completely covered by the rotary valve. Refer to Fig. 3-15.

Changing the width of openings in crankcase and rotary valve cover can change the inlet timing. Changing the height of the openings can prevent valve from sealing. Careful matching of port openings in crankcase and rotary valve cover to each other and to the rotary valve may result in better performance.

### SEALING

Many products are available for sealing around grommets, wires, hoses and covers to prevent entrance of water and/or dust. For many types of riding, it is advisable to raise the entrance for air to the carburetor (air cleaner), ignition compartment vent, transmission vent and clutch compartment vent. Hoses attached to the vent tubes can be routed to a higher location.

### EXHAUST TUNING

One of the most interesting and effective tools for tailoring the performance of a two stroke engine is the "Tuned Exhaust" or "Expansion Chamber". Technically, the two terms are not interchangeable, but because of common usage they have come to have a similar meaning. A third term related to exhaust design but not interchangeable with the other two is "Silencing". It might be worthwhile at this point to briefly define the terms as they are used here.

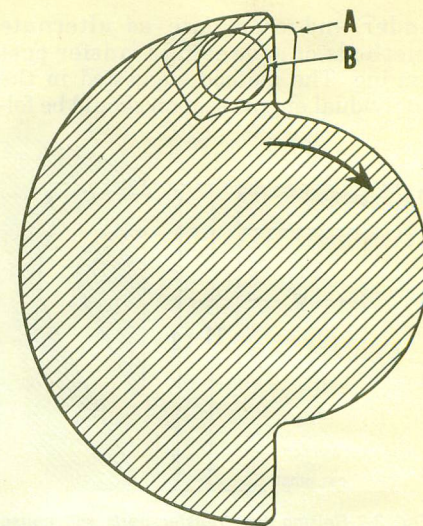

Fig. 3-15—The rotary valve is closed when one of the ports is completely covered. Usually opening (B) in rotary valve cover is smaller and is the first covered.

**EXPANSION CHAMBER.** There are three reasons why the exhaust gases of a two stroke engine are not released directly into the atmosphere. Two of these reasons, "Noise Control" and "Flame Suppression" apply to the entire family of engines whether they are two stroke, four stroke or rotating combustion type. The third reason "Performance Improvement" applies mainly to two stroke engines. Any enclosed area including a muffler or silencer, into which the exhaust empties is properly called an expansion chamber. But in common usage the term applies mainly to those units which improve performance.

A **TUNED EXHAUST** carries the performance oriented expansion chamber one step further and makes use of the reflected sound wave to further improve performance.

**MUFFLERS** are expansion chambers which quiet exhaust noise. Most motorcycle standard exhaust systems are carefully matched to the engine in order to increase power as well as reducing noise level. Removal of muffler or muffler parts (baffles) will nearly always decrease performance. Some racing expansion chambers are designed with a silencer built in the outlet pipe (stinger) or with provision for adding a silencer to the outlet pipe.

**OPERATION.** In the exchange cycle of a two stroke engine, the exhaust gases are removed from the cylinder and the cylinder recharged from the crankcase for the next cycle. Efficiency and power will be greatest when this exchange is completed at the highest possible cylinder pressure as

## FUNDAMENTALS

the exhaust ports close. It should be remembered that, at 6000 rpm the complete operating cycle occurs 100 times a second and the exchange cycle occupies only about 60% of the total cycle. Therefore the exchange takes place in the smallest fraction of a second.

During the exchange cycle of an engine equipped with an expansion chamber, several events occur simultaneously; a rise of pressure in the expansion chamber, the exchange of gases in the cylinder, and the lowering of pressure in the crankcase. If the first and last events are properly balanced, complete exchange of gases is accomplished at a pressure equal to or above ambient atmospheric pressure. The higher the pressure (or the denser the fresh charge) the greater the horsepower output. If the expansion chamber is too small, improperly designed, or the outlet partially blocked, there will be incomplete exchange of gases in the cylinder, some exhaust gas will remain and output will suffer. If the expansion chamber is too large (not designed for the engine) no improvement is gained.

It should be remembered that a cylinder ported engine is symmetrical in design. An exhaust port that is uncovered at 110° after TDC on the power stroke will be closed 110° before TDC on the compression stroke. The exhaust port must open before the transfer ports, and therefore must close after the transfer ports close. "Exhaust Tuning" attempts to hold the pressure in the cylinder above that of the outside air when the exhaust ports close to trap the charge. The principle involved is the same as that which produces the echo when sound is directed toward a distant object. When the exhaust port opens on a two cycle engine, the escaping gases create an explosive noise which enters the expansion chamber with the exhaust gas. The main force of the sound wave travels straight outward until it escapes or is reflected by the expansion chamber walls. A

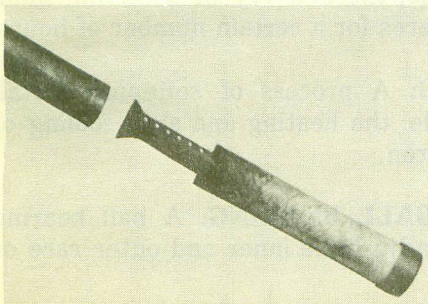

Fig. 3-16—Horsepower may be increased without an increase in noise. View of "Hooker Exhaust Tuner" with fiberglass wrapped perforated stinger core.

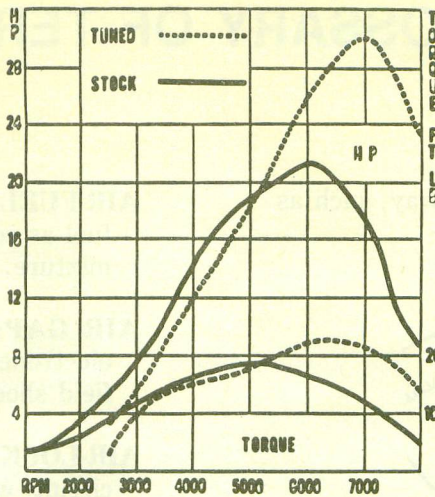

Fig. 3-18—Advertised horsepower and torque curves of a 250 cc single cylinder motorcycle showing performance variations obtainable.

TUNED exhaust returns the reflected sound wave to the exhaust ports while the ports are still open and after the transfer ports have closed. The sound wave is accompanied by a pressure rise which reverses the outflow of scavenging gases at the exhaust ports as they are closing, thus increasing the density of the fuel mixture in the cylinder. Exhaust tuning is effective through a relatively narrow range of engine operation and the area of improvement can be detected from the sound and feel of engine performance. To be fully effective, exhaust tuning should be accompanied by other changes, including carburetion, port timing and induction. Fig. 3-18 shows the advertised performance curves of a stock and factory tuned 250cc single cylinder motorcycle engine. The effect of tuning is most apparent by the reverse bend of the torque curve at 5000 rpm and by the wide divergence of the two horsepower curves at the upper end.

**CONSTRUCTION.** Specifications are included in specific Speed Tuning sections for building expansion chambers for individual models. Construction is sometimes difficult; however, units are available which are ready to bolt onto many popular motorcycle

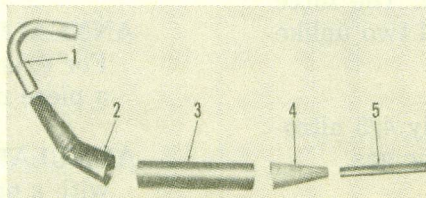

Fig. 3-19—The expansion chamber shown can be welded together of separate pieces. Specifications for header pipe (1), divergent cone (2), chamber body (3), convergent cone (4) and stinger (5) are included in text for individual models.

## Speed Tuning

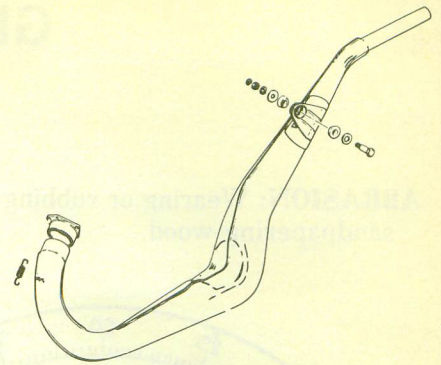

Fig. 3-19A—Drawing of a typical factory expansion chamber. Units are usually stamped and conform to fit closely to specific models.

models. Some of the expansion chambers available are manufactured from stampings (Fig. 3-19A) which permit the chamber to curve smoothly around engine and frame components without causing restrictions.

Others are manufactured from cones and cylinders which are welded together to create the expansion chamber (Fig. 3-19).

### SPECIAL NOTES

It is important that all screws and nuts be secured, using safety wire, lock plates, lock washers, self-locking nuts or locking compound (such as LOC-TITE). All parts should be checked often for security.

Be extremely careful when filling the fuel tank. Filters should be used to prevent foreign matter from entering tank. Check the fuel filters on vehicle at regular intervals and renew units when in doubt, to prevent lean mixture from damaging engine.

### SUMMARY

The expected results of engine modifications are more torque and more RPM. The materials used to manufacture motorcycle engines do have a stress limit at which point any given part will fail. It is much easier to exceed the limits of the materials after modification and much more caution should be exercised. As an example, it may be impossible to exceed the RPM limit (Red Line) in any gear except first before modification; however after modification the RPM limit may be exceeded in the lower three gears. It is also possible that the suspension components will not withstand the increased strains.

The end result of full race tuning is outstanding performance over a relatively narrow operating range. There will be corresponding sacrifices in service life, operating economy, ease of starting and dependability.

# GLOSSARY OF TERMS

**ABRASION:** Wearing or rubbing away, such as sandpapering wood.

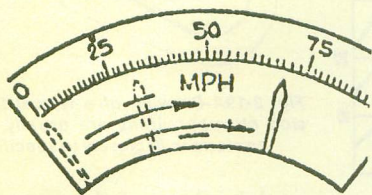

ACCELERATION

**ACCELERATION:** The increase in velocity or speed.

**ACETYLENE OR OXY-ACETYLENE WELDING:** The utilization of an acetylene flame to provide heat to bring metal to the fusion or melting point when uniting it.

**ADDITIVE:** As used with reference to automotive oils, a material added to the oil to give it certain properties. For example, a material added to engine oil to lessen its tendency to congeal or thicken at low temperature.

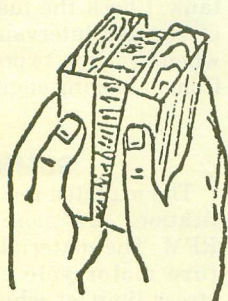

ADHESION

**ADHESION:** The tendency for the surface of one substance to stick to another. The force that holds together the surfaces of two unlike substances.

**AIR:** A gas containing approximately 4/5 nitrogen, 1/5 oxygen and some carbonic gas.

**AIR CLEANER:** A device for filtering, cleaning, and removing dust from the air admitted to a unit, such as an engine or air compressor.

**AIR-FUEL RATIO:** The ratio by weight of the fuel as compared to the air of the carburetor mixture.

**AIR GAP:** The space between spark plug electrodes, motor and generator armatures, field shoes, etc.

**AIR-LOCK:** A bubble of air trapped in a fluid circuit which interferes with normal circulation of the fluid.

**ALIGNMENT:** An adjustment to a line or to bring into a line.

**ALLEN WRENCH:** A hexagonal wrench which fits into a recessed hexagonal hole. Ordinarily used in set screws or very hard screws.

**ALLOY:** A mixture of different metals such as solder which is an alloy consisting of lead and tin.

**ALTERNATING CURRENT:** An electrical current continuously reversing its direction of flow.

**ALUMINUM:** A metal noted for its lightness and often alloyed with small quantities of other metals.

**AMMETER:** An instrument for measuring the flow of an electrical current.

**AMPERE:** The unit of measurement for the flow of electric current.

**AMPERE-HOUR CAPACITY:** A term used to indicate the capacity of a storage battery. For example, the delivery of a certain number of amperes for a certain number of hours.

**ANNEALING:** A process of softening metal. For example, the heating and slow cooling of a piece of iron.

**ANNULAR BALL BEARING:** A ball bearing with a non-adjustable inner and outer race or races.

**ANODE:** A positive pole or electrode of an electrical circuit.

**ANTI-CLOCKWISE ROTATION:** Rotating the opposite direction of the hands on a clock. The same as counter-clockwise rotation.

**ANTI-FREEZE:** A material such as alcohol, glycerin, etc., added to water to lower its freezing point.

**ANTI-FRICTION BEARING:** A bearing constructed with balls, rollers or the like between the journal and the bearing surface to provide rolling instead of sliding friction.

**APERTURE:** An opening, hole or port.

**API:** American Petroleum Institute.

**ARC WELDING:** A method of utilizing the heat of an electric current jumping an air gap to provide heat for welding metal.

**ARMATURE:** That part of an electrical machine which includes the main current-carrying winding which rotates within the pole shoes which are surrounded by the field coils.

**ASBESTOS:** A natural fibrous mineral with great heat resisting ability.

**ATMOSPHERIC PRESSURE:** The weight of the air at sea level; about 14.7 lbs. per square inch; less at higher altitudes.

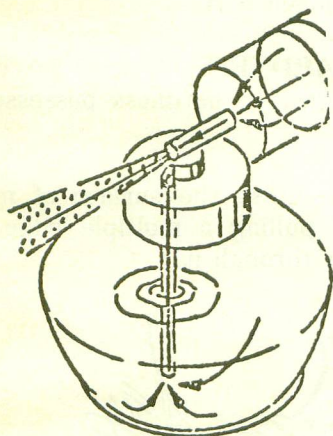

ATOMIZE

**ATOMIZE:** To break up a liquid into minute particles such as a fine spray.

**B & S GAGE:** Brown and Sharpe gage which is a standard measure of wire size. The smaller the number, the larger the wire.

**BACKFIRE:** An explosion in the exhaust system caused by incorrect timing or poor combustion. Backfire may also occur through the intake manifold and carburetor with a premature firing of the combustion mixture.

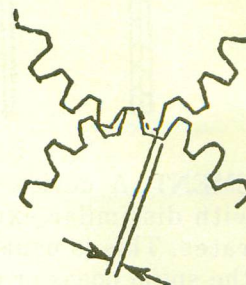

BACKLASH

**BACKLASH:** The play between mating-gear teeth. This is measured as the amount of movement of one gear against another that is held stationary.

**BACK-PRESSURE:** A resistance to free flow, such as a restriction in the exhaust line.

**BAFFLE OR BAFFLE PLATE:** An obstruction for checking or deflecting the flow of gases or sound.

**BALL BEARING:** An anti-friction bearing consisting of a hardened inner and outer race with hardened steel balls interposed between the two races.

**BATTERY:** Any number of complete electrical cells assembled in one housing or case.

**BBDC:** Before Bottom Dead Center.

**B.D.C.:** Bottom Dead Center.

**BEARING:** A part in which a journal, pivot or the like turns or moves.

**BENZOL:** A by-product of the manufacture of coke sometimes used as an engine fuel.

**BEZEL:** The groove in which a transparent instrument cover is placed.

**B.H.P. (BRAKE HORSEPOWER):** A measurement of the power developed by an engine in actual operation.

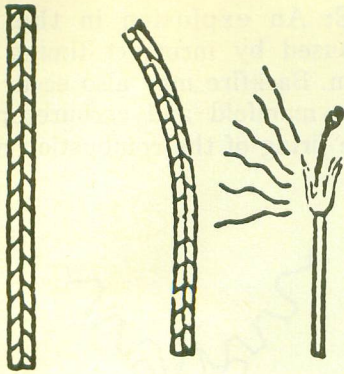

**BIMETAL ELEMENT:** A device composed of two metals with dissimilar expansion and contraction rates. This is usually a spiral-shaped unit; the spiral opens or closes as the temperature changes.

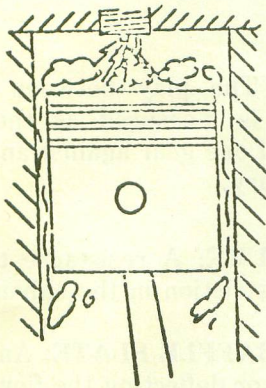

**BLOW-BY**

**BLOW-BY:** The excessive leaking of the expanding combustion force in the cylinder. This may be past leaky piston rings into the crankcase or past leaky valves into the intake or exhaust systems.

**BOILING POINT:** The temperature at atmospheric pressure at which bubbles or vapors rise to the surface and escape.

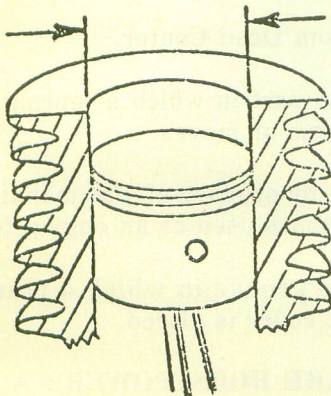

**BORE**

**BORE:** The diameter of a hole, such as a cylinder; also the hole into which a bearing is installed.

**BORING BAR:** A stiff bar equipped with multiple cutting bits which is used to bore a series of bearings or journals in proper alignment with each other.

**BOSS:** An extension or strengthened section, such as the projections within a piston which support the piston pin or piston pin bushings.

**BOTTLED GAS:** Liquefied petroleum gas compressed and contained in portable cylinders.

**BRAZE:** To join two pieces of metal with the use of a comparatively high melting point material. An example is to join two pieces of steel by using brass or bronze as a solder.

**BREAKER ARM:** The movable part of a pair of contact points in an electrical distributor or magneto.

**BREAKER POINT:** Also called contact points. Two separable points usually faced with silver, platinum or tungsten which interrupt the primary circuit in the distributor or magneto for the purpose of inducing a high tension current in the ignition system.

**BREAK-IN:** The process of wearing in to a desirable fit between the surfaces of two new or reconditioned parts.

**BRINELL HARDNESS:** A scale for designating the degree of hardness possessed by a substance.

**BROACH:** To finish the surface of metal by pushing or pulling a multiple edge cutting tool over or through it.

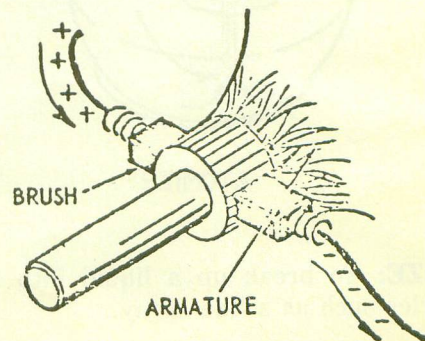

**BRUSH (ELECTRICAL)**

**BRUSHES:** The bars of carbon or other conducting material which contact the commutator of an electric motor or generator or the slip rings of an alternator.

**B.T.U. (British Thermal Unit):** A measurement of the amount of heat required to raise the temperature of 1 lb. of water, 1 degree, Fahrenheit.

**BUCKLED PLATES:** Battery plates that have been bent or warped out of a flat plane.

**BURNISH:** To smooth or polish by the use of a sliding tool under pressure.

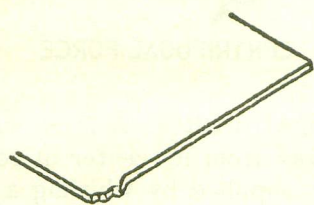

**BURR**

**BURR:** A thin, rough edge of metal left on the tip of a part being machined, ground or filed.

**BUSHING:** A removable liner for a bearing.

**BUTANE:** A petroleum hydrocarbon compound which has a boiling point of about 32 degrees F. which is used as engine fuel. Loosely referred to as Liquefied Petroleum Gas and often combined with Propane.

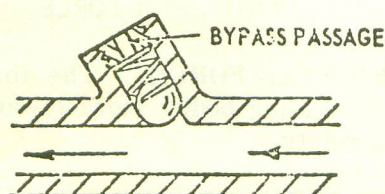

**BYPASS**

**BY-PASS:** A passage, usually with a valve arrangement, giving an alternate route for liquids or vapors.

**CALIBRATE:** To determine or adjust the graduation or scale of any instrument giving quantitative measurements.

**CALIPERS (Inside and Outside):** An adjustable tool for determining the inside or outside diameter by contact and retaining the dimension for measurement or comparison.

**CALORIFIC VALUE:** A measure of the heating value of fuel.

**CALORIMETER:** An instrument to measure the amount of heat given off by a substance when burned.

**CALORIE:** The metric measurement of the amount of heat required to raise 1 gram of water from zero degrees to 1 degree Centigrade, at normal atmospheric pressure.

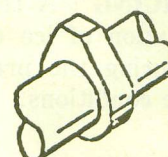

**CAM**

**CAM:** A wheel-like projection from a shaft with an extended lobe for moving or lifting some adjacent part.

**CAM ANGLE:** Also known as dwell period. Referring to an ignition distributor, the number of degrees of rotation of the ignition distributor shaft during which the contact points are closed.

**CAM FOLLOWER:** A lever, plunger or bell-crank which follows the profile of the cam and transmits this motion to other parts. Usually operating the engine valves.

**CAM GROUND PISTON:** A piston ground to a slightly oval shape which under the heat of operation becomes round.

**CAMSHAFT:** The shaft containing lobes or cams to operate the engine valves.

**CAPE CHISEL:** A metal cutting chisel shaped to cut or work in channels or grooves.

**CARBON:** A common non-metallic element which is an excellent conductor of electricity. It also forms in the combustion chamber of an engine during the burning of fuel and lubricating oil.

**CARBON DIOXIDE:** Compressed into solid form, this material is known as "dry ice" and remains at a temperature of -109 degrees, F. It goes directly from a solid to a vapor state.

**CARBONIZE:** To coat with carbon. The process of carbon formation with an engine, such as on the spark plugs and within the combustion chamber.

**CARBURETOR:** A device for automatically mixing fuel in the proper proportion with air to produce a combustible gas.

**CARBURETOR "ICING":** A term used to describe the formation of ice on a carburetor throttle plate during the prevalence of certain atmospheric conditions.

**CASE-HARDEN:** To harden the surface of steel.

**CASING HEAD GASOLINE:** A term used to describe the lighter parts of petroleum products which were obtained as a natural gasoline by condensing natural gas from an oil well.

**CASTELLATE:** Formed to resemble a castle battlement as in a castellated nut.

**CATHODE:** The negative pole or terminal of an electric circuit.

**C.C.:** Cubic centimeter.

**CELL:** An electrical cell is the unit of a battery containing a group of positive and negative plates along with electrolyte.

**CELL CONNECTOR:** The lead bar or link connecting the pole of one cell to the pole of another.

**CELLULOID:** A compound of gun cotton and camphor which is flexible and transparent.

**CENTER OF GRAVITY:** The point at which a mass of matter balances. For example, the center of gravity of a wheel is the center of the wheel hub.

**CENTIGRADE:** The metric temperature scale, zero on the Centigrade scale being 32 degrees on the Fahrenheit scale. Also called Celsius.

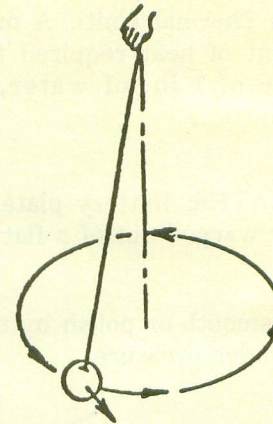

**CENTRIFUGAL FORCE**

**CENTRIFUGAL FORCE:** A force which moves a body away from its center of rotation. An example is supplied by whirling a weight attached to a string.

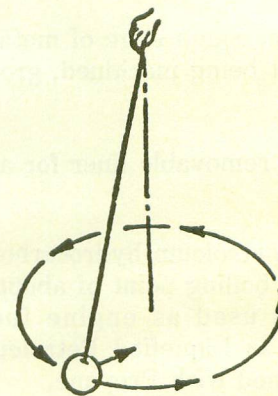

**CENTRIPETAL FORCE**

**CENTRIPETAL FORCE:** The force which makes rotating bodies move toward the center of rotation.

**CHAMFER:** A bevel or taper at the edge of a hole.

**CHARGE (or Recharge):** Passing an electrical current through a battery to restore it to activity.

**CHASE:** To straighten up or repair damaged threads.

**CHECK-VALVE:** A gate or valve which allows passage of gas or fluid in one direction only.

**CHEMICAL COMPOUND:** The combination of two or more chemical elements which can be a gas, a liquid or a solid.

**CHEMICAL ELEMENT:** Gaseous, liquid or solid matter which cannot be divided into simpler form.

**CHILLED IRON:** Cast iron on which the surface has been hardened.

**CHIP:** To cut with a chisel.

**CHOKE:** A reduced passage, such as a valve placed in a carburetor air inlet to restrict the volume of air admitted.

**CHROMIUM STEEL:** An alloy of steel with a small amount of chromium to produce a metal which is highly resistant to oxidation and corrosion.

**CIRCUIT:** The path of electrical current, fluids or gases. Examples: for electricity, a wire; for fluids and gases, a pipe.

**CIRCUIT BREAKER:** A device for interrupting an electrical circuit; often automatic and may be known as "contact breaker," "interrupter," "cut-out" or "relay".

**CLEARANCE:** The amount of space between two adjacent moving parts, or between one moving and one stationary part such as between a journal and a bearing.

**CLOCKWISE ROTATION:** Rotation in the same direction as the hands of a clock.

**COEFFICIENT OF FRICTION:** A measurement of the amount of friction developed between two surfaces pressed together and moved one on the other.

**"COLD" MANIFOLD:** An intake manifold to which the exhaust gas is not applied for heating purposes.

**COMBUSTION:** The act or process of burning.

**COMBUSTION SPACE OR CHAMBER:** In internal combustion engines, the volume of the cylinder above the piston with the piston on top center.

**COMMUTATOR:** A ring of adjacent copper bars insulated from each other to which the

wires of the armature or winding are attached.

**COMPOUND:** A mixture of two or more ingredients.

**COMPOUND WINDING:** Two electric windings, one in series and the other in shunt or parallel with other electric units or equipment. When applied to electric motors or generators, one winding is shunted across the armature while the other is in series with the armature.

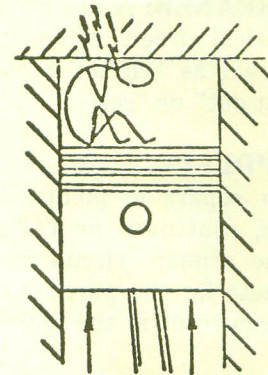

COMPRESSION

**COMPRESSION:** The reduction in volume or the "squeezing" of a gas. As applied to metal, such as a coil spring, compression is the opposite of tension.

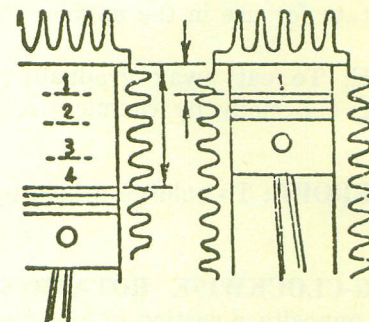

COMPRESSION RATIO

**COMPRESSION RATIO:** The ratio of the volume in the cylinder when the piston is at top-dead-center to the volume in the cylinder when the piston is at bottom-dead-center.

**CONCENTRIC:** Two or more circles having a common center.

**CONDENSATION:** The process of a vapor becoming a liquid; the reverse of evaporation.

**CONDENSER:** A device for turning vapor into liquid form if applied to gas. If applied to an electric circuit, the condenser is a device for temporarily collecting and storing a surge of electrical current for later discharge.

**CONDUCTOR:** A material along or through which electricity will flow with slight resistance; silver, copper and carbon are good conductors.

**CONNECTING ROD:** Rod that connects the piston to the crankshaft.

**CONTACT BREAKER:** A device for interrupting an electrical circuit; often automatic and may be known as "circuit breaker," "interrupter," "cut-out" or "relay".

**CONTACT POINTS:** Also called breaker points. Two separable points usually faced with silver, platinum or tungsten which interrupt the primary circuit in the distributor or magneto for the purpose of inducing a high tension current in the ignition system.

**CONTRACTION:** A reduction in mass or dimension; the opposite of expansion.

**CONVECTION:** A transfer of heat by circulating heated air.

**CONVERTER:** As used in connection with liquefied petroleum gas, it is a device which converts or changes L.P.G. from liquid to vapor state for use in the engine.

**CORRODE:** To eat away gradually as if by gnawing, especially by chemical action, such as rust.

**COUNTERBORE:** To enlarge a hole to a given depth.

**COUNTER-CLOCKWISE ROTATION:** Rotating the opposite direction of the hands on a clock. The same as anti-clockwise rotation.

**COUNTERSINK:** To cut or form a depression to allow the head of a screw to go below the surface.

**COUNTERWEIGHT:** The weight added to a shaft to balance the normal load and offset vibration.

**COUPLING:** A connecting means for transferring movement from one part to another; may be mechanical, hydraulic or electrical.

**CRANKCASE:** The housing within which the crankshaft and many other parts of the engine operate.

**CRANKCASE DILUTION:** Under certain conditions of operation, unburned portions of the fuel find their way past the piston rings into the crankcase and oil reservoir where they dilute or "thin" the engine lubricating oil.

**CRANKSHAFT:** The main shaft of an engine which in conjunction with the connecting rods changes the reciprocating motion of the pistons into rotary motion.

**CRANKSHAFT COUNTER-BALANCE:** A series of weights attached to or forged integrally with the crankshaft so placed as to offset the reciprocating weight of each piston and rod assembly.

**CRUDE OIL:** Liquid oil as it comes from the ground.

**CU. IN.:** Cubic inch.

**CURRENT:** The flow rate of electricity, measured in Amperes.

**CUT-OUT (Electric):** A device for interrupting an electrical circuit; often automatic and may be known as "circuit breaker," "interrupter," "contact breaker," or "relay."

**CUT-OUT (Muffler):** A valve which can be used to divert the exhaust gases directly to the atmosphere instead of through the muffler.

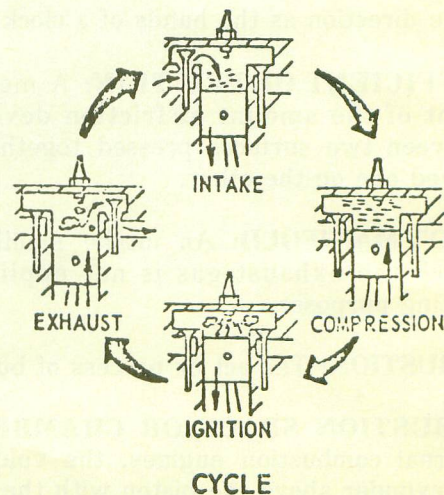

**CYCLE:** A series of occurrences in which conditions at the end of the series are the same as they were at the beginning.

**CYLINDER:** A round hole having some depth bored to receive a piston; also sometimes referred to as "bore" or "barrel."

**CYLINDER BLOCK:** The largest single part of an engine. The basic or main mass of metal in which the cylinders are bored or placed.

**CYLINDER HEAD:** A detachable portion of an engine fastened securely to the cylinder block which contains all or a portion of the combustion chamber.

**CYLINDER SLEEVE:** A liner or tube interposed between the piston and the cylinder wall or cylinder block to provide a readily renewable wearing surface for the cylinder.

**DASH POT:** A device consisting of a piston and cylinder with a restricted opening used to slow down or delay the operation of some moving part.

**DEAD CENTER:** The extreme upper or lower position of the crankshaft throw at which the piston is not moving in either direction.

**DEGREE:** Abbreviated deg. or indicated by a small "o" placed alongside a figure; may be used to designate temperature readings or may be used to designate angularity, one degree being 1/360 part of a circle.

**DEMAGNETIZE:** To remove the magnetism of a pole which has previously been magnetized.

**DENATURED ALCOHOL:** Ethyl alcohol to which a denaturant has been added to make it unfit as a beverage.

**DENSITY:** Compactness; relative mass of matter in a given volume.

**DEPOLARIZE:** To remove polarity, such as to demagnetize a permanent magnet.

**DETERGENT:** A compound of a soap-like nature used in engine oil to remove engine deposits and hold them in suspension in the oil.

**DETONATION:** Indicates a too rapid burning or explosion of the mixture in the engine cylinders. It becomes audible through a vibration of the combustion chamber walls and is sometimes confused with a "ping" or spark knock.

**DIAL GAUGE (Dial Indicator):** A type of micrometer wherein the readings are indicated on a dial rather than on a thimble as in a micrometer.

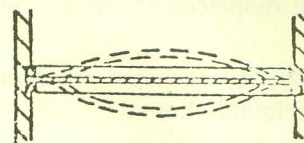

DIAPHRAGM

**DIAPHRAGM:** A stationary disc or partition which can flex in the center while the edges are clamped. A flexible partition or wall separating two cavities.

**DIE:** One of a pair of hardened metal blocks for forming metal into a desired shape or thread die for cutting external threads.

**DIE CASTING:** An accurate and smooth casting made by pouring molten metal or composition into a metal mold or die under pressure.

**DIESEL ENGINE:** Named after its developer, Dr. Rudolph Diesel, the engine ignites the fuel in the cylinder from the heat generated by compression. The fuel is an oil rather than gasoline and no spark plug or carburetor is required.

**DIRECT CURRENT:** Electric current which flows continuously in one direction. An example is a storage battery.

**DISCHARGE:** With reference to a battery, the flow of electric current from the battery; the opposite of charge.

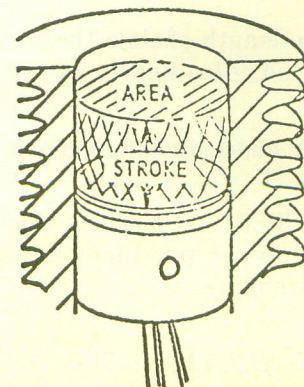

DISPLACEMENT

**DISPLACEMENT (Engine Displacement):** The volume added to the combustion chamber in the cylinder when the piston moves from the top to the bottom of its stroke (area times stroke length). In a multi-cylinder engine, it is the total displacement of all cylinders.

**DISTORTION:** A warpage or change in form from the original shape.

**DOG CLUTCH:** Mating collars or flanges with projecting lugs or fingers which interlock when engaged.

**DOWEL PIN:** A pin inserted in matching holes in two parts to maintain those parts in fixed relation one to the other.

**DOWN-DRAFT:** Used to describe a carburetor type wherein the mixture flows downward to the engine.

**DRAW:** To form by stretching process or to soften hard metal.

**DRAW-FILING:** A method of filing wherein the file is drawn across the work while held at a right angle to the length of the file.

**DRIVE-FIT:** Also known as a force-fit or press-fit. This term is used when the shaft is slightly larger than the hole and must be forced in place.

**DROP FORGING:** A piece of steel shaped between dies while hot.

**DRY BATTERIES:** Also called dry cell. A complete battery unit which does not contain liquid electrolyte.

**DWELL:** The length of time the breaker points remain closed. Also known as cam angle.

**DYNAMO:** A generator of electricity.

**DYNAMOMETER:** A machine for measuring the actual power produced by an internal combustion engine.

**EARTH CONNECTION:** This term is sometimes used to designate a "ground" in the electrical system. See Ground.

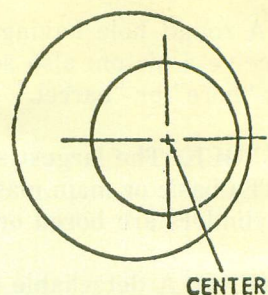

**ECCENTRIC**

**ECCENTRIC:** One circle within another circle wherein both circles do not have the same center. An example of this is a cam on a camshaft.

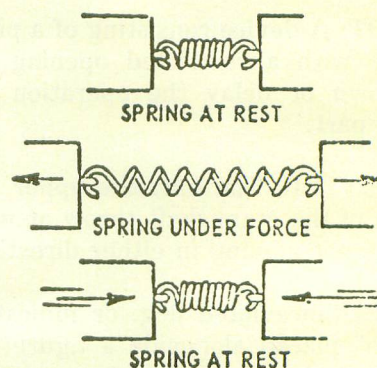

**ELASTICITY**

**ELASTICITY:** The property of a substance that causes it to return to its original shape and size after being deformed or stretched.

**ELECTRODE:** Usually refers to the insulated center rod of a spark plug. It is also sometimes used to refer to the rods attached to the shell of the spark plug.

**ELECTROLYTE:** Liquid or paste which carries current, as the mixture of sulphuric acid and distilled water used in storage batteries of the wet type.

**ELECTRO-MAGNET:** A coil of insulated wire wound around an iron rod or series of rods will magnetize the rod or rods and cause it to attract any other iron in the vicinity provided an electrical current is passed through the wire. An example of this is a solenoid magnet.

**ELEMENT:** One set of positive plates and one set of negative plates complete with separators assembled together.

**E.M.F. (Electromotive Force):** See Voltage.

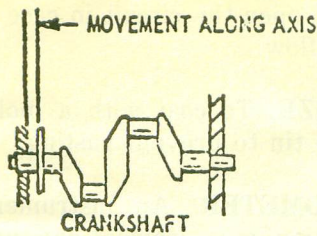

END PLAY

**END PLAY:** The movement along the axis of a mounted shaft.

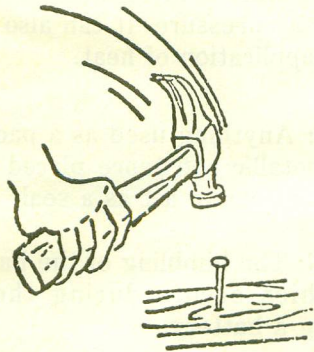

ENERGY

**ENERGY:** A force capable of producing work.

**ETHYL GASOLINE:** Gasoline to which Ethyl fluid has been added. Ethyl fluid is a compound of tetraethyl lead, ethylene dibromide and thylene dichloride. The purpose of the material is to slow down and control the rate of burning of the fuel in the cylinder to produce an expansive force rather than an explosive force and thus reduce detonation or "knocking" in an engine.

**EVAPORATION:** The process of changing from a liquid to a vapor, such as boiling water to produce steam; evaporation is the opposite of condensation.

**EXCITER:** Often used in referring to the third brush where this mode of regulation is used for a generator.

**EXHAUST GAS ANALYZER:** An instrument for determining the efficiency with which an engine is burning fuel.

**EXHAUST PIPE:** The pipe connecting the engine to the muffler to conduct the exhausted or spent gases away from the engine.

**EXPANSION:** An increase in size. For example, when a metal rod is heated it increases in length and perhaps also in diameter; expansion is the opposite of contraction.

**FAHRENHEIT (F.):** A scale of temperature measurement used in some countries. The boiling point of water is 212 degrees, Fahrenheit, as compared to 100 degrees Centigrade.

**FEELER GAGE:** A metal strip or blade finished accurately with regard to thickness used for measuring the clearance between two parts.

**FERROUS METAL:** Metals which contain iron or steel and are therefore subject to rust.

**F-HEAD ENGINE:** A four stroke engine designed with one valve in the cylinder block at the side of the piston and the other valve in the cylinder head above the piston.

**FIELD:** In a generator or electric motor the area in which magnetic flow occurs.

**FIELD COIL:** A coil of insulated wire surrounding the field pole.

**FILE:** To finish or trim with a hardened rasp or file.

**FILLET:** A rounded filling between two parts joined at an angle.

**FILTER (Oil, Water, Gasoline, Etc.):** A unit containing an element, such as a screen of varying materials depending upon the size of the foreign particles to be eliminated from the fluid being filtered.

**FIN:** One of a series of metal projections from a surface designed to provide increased surface exposure for air cooling or heat transfer.

**FIT:** A kind of contact between two machined surfaces.

**FLANGE:** A projecting rim or collar on an object for keeping it in place.

**FLASH POINT:** The temperature at which an oil when heated will flash and burn.

**FLOAT:** A hollow tank which is lighter than the fluid in which it rests and which is

ordinarily used to operate automatically a valve controlling the entrance of the fluid.

**FLOATING PISTON PIN:** A piston pin which is not locked in the connecting rod or the piston, but is free to turn or oscillate in both the connecting rod and the piston.

**FLOAT LEVEL:** The pre-determined height of the fuel in the carburetor bowl, usually regulated by means of a suitable valve.

**"FLUTTER" OR "BOUNCE":** As applied to engine valves, refers to a condition wherein the valve is not held tightly on its seat during the time the cam is not lifting it.

**FLUX, ELECTRIC OR MAGNETIC:** Lines of magnetic force passing or flowing in a magnetic field.

**FLUX, SOLDERING WELDING, BRAZING:** The material used to cause the joining metal to adhere to both parts to be joined.

**FLYWHEEL:** A heavy wheel in which energy is absorbed and stored by means of momentum.

**FORCE-FIT:** Also known as a press-fit or drive-fit. This term is used when the shaft is slightly larger than the hole and must be forced in place.

**FORGE:** To shape metal while hot by hammering.

**FOUR STROKE ENGINE:** Also known as Otto cycle, wherein an explosion occurs every other revolution of the crankshaft; a cycle being considered as 1/2 revolution of the crankshaft. These strokes are (1) intake stroke; (2) compression stroke; (3) power stroke; (4) exhaust stroke.

**FRACTURE:** A crack or break in a part.

**FUEL KNOCK:** Same as detonation.

**FULCRUM:** The support on which a lever turns in moving a body.

**FUSE:** A fuse consists of a piece of wire which will carry a limited amount of current only. It is placed in an electrical circuit as a safety measure to avoid damage and is designed to

melt and open the circuit in case of excessive current flow.

**GALVANIZE:** To coat with a molten alloy of lead and tin to prevent rusting.

**GALVANOMETER:** An instrument used for the location, measurement and direction of an electric current.

**GAS:** A substance which can be changed in volume and shape according to the temperature and pressure applied to it. For example, air is a gas which can be compressed into smaller volume and into any shape desired by pressure. It can also be expanded by the application of heat.

**GASKET:** Anything used as a packing, such as a non-metallic substance placed between two metal surfaces to act as a seal.

**GASSING:** The bubbling of the battery electrolyte which occurs during the process of charging a battery.

**GEAR RATIO:** A relationship between the speeds of two or more meshed gears that numerically expresses the speed of the output in proportion to the speed of the input. For example, if one gear makes three revolutions while the other gear makes one revolution, the gear ratio would be 3 to 1.

**GENERATOR:** A device consisting of an armature, field coils and other parts which when rotated will generate electricity.

**GLAZE:** As used to describe the surface of the cylinder, an extremely smooth or glossy surface such as a cylinder wall highly polished over a long period of time by the friction of the piston rings.

**GLAZE BREAKER:** A tool for removing the glossy surface finish in an engine cylinder.

**GOVERNOR:** A device to control and regulate speed. May be mechanical, pneumatic, hydraulic or electrical.

**GRAM:** A metric unit of weight which is equal to 1/454th part of a pound.

**GRID:** The metal framework of an individual battery plate in which the active material is placed.

**GRIND:** To finish or polish a surface by means of an abrasive wheel.

**GROUP:** In a battery a set of plates either positive or negative joined together but not assembled with separators.

**GROWLER:** An electrical device for testing electric motor or generator armatures.

**GUDGEON PIN:** Also known as "wrist pin" and piston pin. This is the pin that connects the connecting rod to the piston and piston pin is the preferred term.

**GUM:** In automotive fuels, this refers to oxidized petroleum products which accumulate in the fuel system, carburetor or engine parts.

**HARD SOLDER:** Uniting two pieces of metal with a material having a melting point higher than "soft" solder. An example is silver soldering wherein silver is used instead of lead-tin alloy.

**HARMONIC BALANCER:** A device to reduce the torsional or twisting vibration which occurs along the length of the crankshaft used in multiple cylinder engines. Also known as a vibration damper.

**HEAT TREATMENT:** A combination of heating and cooling operations timed and applied to a metal in a solid state in a way that will produce desired properties.

**HEEL:** The outside or larger half of the gear tooth.

**HELICAL:** Shaped like a coil of wire or a screw thread.

**HELICAL GEAR:** A gear design wherein the gear teeth are cut at an angle to the shaft.

**HERRINGBONE GEAR:** A pair of helical gears designed to operate together in which the angle of the pair of gears forms a V.

**HIGH TENSION (HIGH VOLTAGE):** As used in electricity, it refers to the secondary or induced high voltage electrical current; includes the wiring from the cap of the ignition distributor to the coil and to each of the spark plugs.

**HONE:** An abrasive tool for correcting small irregularities or differences in diameter in a cylinder, such as an engine cylinder.

**HOT SPOT:** Refers to a comparatively thin section or area of the wall between the inlet and exhaust manifold of an engine, the purpose being to allow the hot exhaust gases to heat the comparatively cool incoming mixture. Also used to designate local areas of the cooling system which have attained above average temperatures.

**HP (HORSEPOWER):** The energy required to lift 550 lbs. 1 ft. in 1 second or 33,000 lbs. 1 ft. in 1 minute.

**HYDROCARBON:** Any compound composed entirely of carbon and hydrogen, such as petroleum products.

**HYDROCARBON ENGINE:** An engine using petroleum products, such as gas, liquefied gas, gasoline, kerosene or fuel oil as a fuel.

**HYDROMETER:** An instrument for determining the state of charge in a battery by finding specific gravity of the electrolyte.

**I.D.:** Inside Diameter.

**IDLE:** Refers to the engine operating at its slowest speed.

**IGNITION DISTRIBUTOR:** An electrical unit sometimes containing the circuit breaker for the primary circuit and providing a means for conveying the secondary or high tension current to the spark plug wires as required.

**IGNITION SYSTEM:** The means for igniting the fuel in the cylinders; includes spark plugs, wiring, ignition distributor, ignition coil and source of electrical current supply.

**INDUCTION:** The influence of magnetic fields of different strength not electrically connected to one another.

**INDUCTION COIL:** Essentially a transformer which through the action of induction creates a high tension current by means of an increase in voltage.

**INERTIA:** The tendency of objects to remain forever in a state of rest if at rest, or to continue in the same motion unless disturbed by an external force.

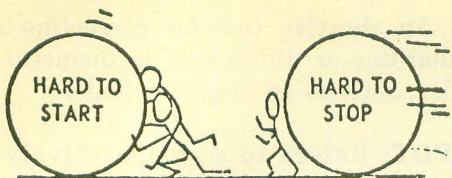

INERTIA

**INHIBITOR:** A material to restrain or hinder some unwanted action, such as a rust inhibitor which is a chemical added to cooling systems to retard the formation of rust.

**INLET VALVE OR INTAKE VALVE:** A valve which permits a fluid or gas to enter a chamber and seals against exit.

**INSULATION:** Any material which does not conduct electricity; used to prevent the flow or leakage of current from a conductor. Also used to describe a material which does not conduct heat readily.

**INSULATOR:** An electrical conductor covered or shielded with a non-conducting material, such as a copper wire, within a rubber tube.

**INTAKE MANIFOLD:** The tube used to conduct the gasoline and air mixture from the carburetor to the engine cylinders.

**INTEGRAL:** The whole made up of parts.

**INTENSIFY:** To increase or concentrate, such as to increase the voltage of an electrical current.

**INTERMITTENT:** Motion or action that is not constant but occurs at intervals.

**INTERNAL COMBUSTION:** The burning of a fuel within an enclosed space.

**INTERRUPTER:** A device for interrupting an electrical circuit; often automatic and may be known as "contact breaker," "circuit breaker," "cut-out" or "relay".

**I.S.O.:** International Standards Organization.

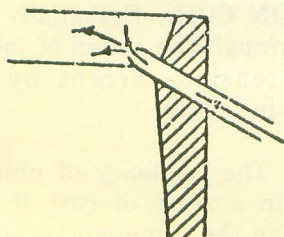

JET

**JET:** A small, tube-like device or hole through which a fluid or gas flows.

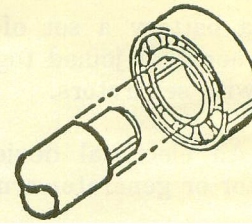

JOURNAL

**JOURNAL:** The part of a shaft which is machined to fit a bearing.

**JUMP SPARK:** A high tension electrical current which jumps through the air from one terminal to the other.

**KEEPER:** See Valve Key.

**KEY:** A small block inserted between the shaft and hub to prevent circumferential movement.

**KEYWAY OR KEYSEAT:** A groove or slot cut to permit the insertion of a key.

**KILOWATT:** A measure of electrical energy consisting of 1,000 watts; it is equal to 1-1/3 horsepower.

**KNURL:** To indent or roughen a finished surface.

**KNOCK:** A general term used to describe various noises occurring in an engine; may be used to describe noises made by loose, broken or worn mechanical parts, pre-ignition, detonation, etc.

**LAMINATE:** To build up or construct out of a number of thin sheets. An example is the laminated core in an electric motor or generator.

**LAPPING:** The process of fitting one surface to another by rubbing them together with an abrasive material between the two surfaces.

**L-HEAD ENGINE:** An engine design in which both valves are located in the cylinder block on one side of the engine cylinder.

**LINER:** Usually a thin section placed between two parts, such as a replaceable cylinder liner in an engine.

**LINKAGE:** Any series of rods, belcranks, yokes, and levers, etc., used to transmit motion from one unit to another.

**LIQUID:** Any substance which assumes the shape of the vessel in which it is placed without changing volume.

**LITER:** A metric measure equal to 1000 c.c.

**LIVE:** Electrical parts connected to the insulated side of the electrical system, such as an insulated wire connected to the battery and often referred to as the "hot" wire.

**LOST MOTION:** Motion between a driving part and a driven part which does not cause actuation of the driven part. Also see Backlash.

**L.P.G., LIQUEFIED PETROLEUM GAS:** Made usable as a fuel for internal combustion engines by compressing volatile petroleum gases to liquid form. When so used, must be kept under pressure or at low temperature in order to remain in liquid form.

**MAGNET (Permanent):** Any material which is or has been charged with magnetic power and can retain same, such as a lodestone.

**MAGNETIC FIELD:** The flow of magnetic force or magnetism between the opposite poles of a magnet.

**MAGNETO:** An electrical device which generates current when rotated by an outside source of power; may be used for the generation of either low tension or high tension current.

**MALLEABLE CASTING:** A casting which has been toughened by annealing.

**MANIFOLD:** A pipe with multiple openings used to connect various cylinders to one inlet or outlet.

**MANGANESE BRONZE:** An alloy of copper, zinc and manganese.

**MANOMETER:** A device for measuring a vacuum consisting of a "U" shaped tube partially filled with fluid. One end of the tube is open to the air and the other is connected to the chamber in which the vacuum is to be measured. Water and Mercury are two commonly used fluids. A column of Mercury 30

in. high equals 14.7 lbs. per square in. which is atmospheric pressure at sea level.

**MECHANICAL EFFICIENCY (Engine):** The ratio between the indicated horsepower and the brake horsepower of an engine.

**MERCURY COLUMN:** A reference term used in connection with a Manometer. Readings are given in inches of Mercury.

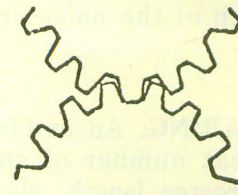

MESH

**MESH:** The fitting of the teeth of one gear wheel into the spaces between another gear wheel, allowing one gear to turn or drive another.

**METHANOL OR WOOD ALCOHOL:** A poisonous alcohol made from distillation of wood; can also be made synthetically.

**MICROMETER:** A measuring instrument for either external or internal measurement in thousandths and sometimes tenths of thousandths of inches.

**MILL:** To cut or machine with rotating tooth cutters.

**MILLIMETER (mm.):** One millimeter is the metric equivalent of .039370 of an inch or one inch being the equivalent of 25.4 mm.

**MISS (MISFIRING):** Failure of an explosion to occur in one or more cylinders while the engine is running; may be continuous or intermittent failure.

**MOLECULE:** Assumed to be the smallest subdivision of a compound representing a single unit of a substance.

**MOMENTUM:** The quantity of motion; the property of a moving body which determines the length of time required to bring it to rest when under the action of a constant force.

**MONO-BLOCK:** Means that complete assembly is contained in one casting; for example, the carburetor venturi and float chamber in one

casting or engine crankcase and cylinder in one casting.

**MOTOR:** Actually this term should be used in connection with an electric motor and should not be used when referring to the engine.

**MUFFLER:** A chamber attached to the end of the exhaust pipe which allows the exhaust gases to expand and cool. It is usually fitted with baffles or porous plates and serves to subdue much of the noise created by the exhaust.

**NEEDLE BEARING:** An anti-friction bearing using a great number of small diameter rollers of greater length; also known as a quill type bearing.

**NICKEL STEEL:** Nickel is alloyed with steel to form a heat and corrosion resistant metal.

**NON-FERROUS METALS:** This designation includes practically all metals which contain no iron or very little iron and are therefore not subject to rusting.

**NORTH POLE:** The pole of a magnet from whence the lines of force start; the opposite of south pole.

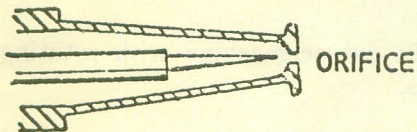

NOZZLE

**NOZZLE:** A device for discharging a gas or liquid in a directed flow.

**OCTANE NUMBER:** A unit of measurement on a scale intended to indicate the tendency of a fuel to detonate or knock.

**O.D.** Outside diameter.

**OFFSET:** To set to one side of center.

**OHM:** A measurement of the resistance to the flow of an electrical current through a conductor.

**O.H.V.:** See Overhead Valve.

**OIL PUMPING:** A term used to describe a four stroke engine which is using an excessive amount of lubricating oil.

**OPEN CIRCUIT:** A break or opening in an electrical circuit which interferes with the passage of the current.

**ORIFICE:** A small opening in a passage, jet, or nozzle.

**OSCILLATE:** To swing back and forth like a pendulum.

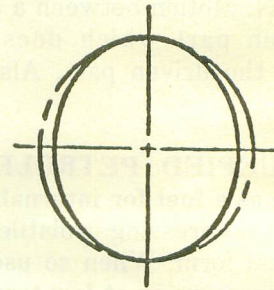

OUT-OF-ROUND

**OUT-OF-ROUND:** Not a perfect circle.

**OVERDRIVE:** Any arrangement of gearing which produces more revolutions of the driven shaft than of the driving shaft.

**OVERHEAD VALVE OR VALVE-IN-HEAD ENGINE:** An engine design having valves located in the cylinder head directly above the pistons.

**OVERRUN COUPLING:** A device to permit rotation in one direction but not in the other. (Overrunning or sprag clutch.)

**OXIDIZE:** To combine an element with oxygen or convert into its oxide. The process is often accomplished by combination; for example, when carbon burns, it combines with oxygen to form carbon dioxide or carbon monoxide. An example is rusted iron wherein the iron has combined with the oxygen in the air to form an oxide of iron or in other words rust.

**PAWL:** A bar adapted to engage with the teeth of a ratchet or the like used either to prevent or impart motion.

**PEEN:** To stretch or clinch over by pounding with the rounded end of a hammer.

**PERIPHERY:** The circumference of a circle such as the tread of a tire.

**PETCOCK:** A small valve placed at various points in a fluid circuit usually for draining purposes.

**PETROL:** European name for gasoline.

**PETROLEUM:** A group of liquid and gaseous compounds composed of carbon and hydrogen which are removed from the earth.

**PHILLIPS SCREW OR SCREWDRIVER:** A type of screw head having a cross instead of a slot for a corresponding type of screwdriver.

**PHOSPHOR-BRONZE:** An alloy consisting of copper, tin and lead sometimes used in heavy duty bearings.

**PILOT VALVE:** A small valve used to control the action of a larger valve, such as a main valve.

**PINION:** A small gear having the teeth formed in the hub.

**PINION CARRIER:** The mounting or bracket which retains the bearings supporting a pinion shaft.

**PISTON:** A cylindrical part closed at one end which is connected to the crankshaft by the connecting rod. The force of the explosion in the cylinder is exerted against the closed end of the piston causing the connecting rod to move the crankshaft.

**PISTON COLLAPSE:** A condition describing a collapse or a reduction in diameter of the piston skirt due to heat or stress.

**PISTON DISPLACEMENT:** The volume of air moved or displaced by moving the piston from one end of its stroke to the other.

**PISTON HEAD:** That part of the piston above the rings.

**PISTON LANDS:** Those parts of a piston between the piston rings.

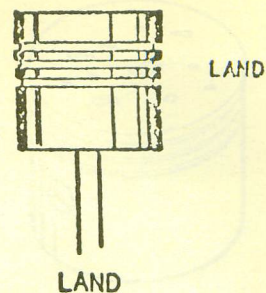

**PISTON PIN:** The journal for the bearing in the small end of an engine connecting rod which also passes through piston walls; also known as a wrist pin.

**PISTON RING:** An expanding ring placed in the grooves of the piston to provide a seal to prevent the passage of fluid or gas past the piston.

**PISTON RING EXPANDER:** A spring placed behind the piston ring in the groove to increase the pressure of the ring against the cylinder wall.

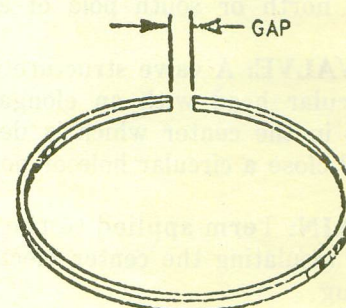

PISTON RING END GAP

**PISTON RING GAP:** The clearance between the ends of the piston ring.

**PISTON RING GROOVE:** The channel or slots in the piston in which the piston rings are placed.

**PISTON SKIRT:** That part of the piston below the rings.

**PISTON SKIRT EXPANDER:** A spring or other device inserted in the piston skirt to compensate for collapse or decrease in diameter.

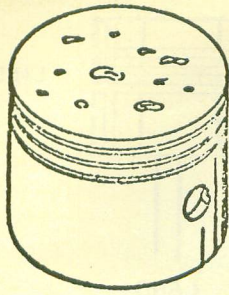

PITTED

**PITTED:** Having small, generally circular, holes or depressions of varying diameter and depth.

**PIVOT:** A pin or short shaft upon which another part rests or turns upon and about which another part rotates or oscillates.

**PLATINUM:** An expensive metal having an extremely high melting point and good electrical conductivity. Sometimes used in breaker points.

**POLARITY:** Refers to the positive or negative terminal of a battery or an electric circuit; also the north or south pole of a magnet.

**POPPET VALVE:** A valve structure consisting of a circular head with an elongated stem attached in the center which is designed to open and close a circular hole or port.

**PORCELAIN:** Term applied to the material used for insulating the center electrode of a spark plug.

**PORT:** In engines, the openings in the cylinder block for valves, exhaust and inlet pipes, or water connections. In two-cycle engines the openings in the cylinder for inlet and exhaust purposes.

**"PORTING":** As applied to racing engines, the enlarging, matching, streamlining and polishing of the inside of the manifolds and valve ports to reduce the friction of the flow of gases.

**POTENTIAL:** An indication of the amount of energy available.

**POTENTIAL DIFFERENCE:** A difference of electrical pressure which sets up a flow of electric current.

**PRE-HEATING:** The application of heat as a preliminary step to some further thermal or mechanical treatment.

**PRE-IGNITION:** Ignition occurring earlier than intended. For example, the explosive mixture being fired in a cylinder as by a flake of incandescent carbon before the electric spark occurs.

**PRE-LOADING:** To place a small amount of pressure or tension on an anti-friction bearing by adjustment to eliminate any semblance of looseness.

**PRESS-FIT:** Also known as a force-fit or drive-fit. This term is used when the shaft is slightly larger than the hole and must be forced in place.

**PRIMARY WINDING:** In an ignition coil or magneto armature is a wire which conducts the low tension current which is to be transformed by induction into high tension current in the secondary winding.

**PRIMARY WIRES:** The wiring circuit used for conducting the low tension or primary current to the points where it is to be used.

**PRONY BRAKE:** A machine for testing the power of an engine while running against a friction brake.

**PROPANE:** A petroleum hydrocarbon compound which has a boiling point about -44 degrees, F. and which is used as an engine fuel; loosely referred to as L.P.G. and often combined with Butane.

**P.S.I.:** Expression of pressure measured in pounds per square inch.

**PUSH ROD:** A connecting link in an operating mechanism, such as the rod interposed between the valve lifter and rocker arm on an overhead valve engine.

**QUENCHING:** A process of rapid cooling of hot metal by contact with liquid, gases or solids.

**QUILL BEARING:** See Needle Bearing.

**RACE:** As used with reference to bearings, a finished inner and outer surface in which or on which balls or rollers operate.

**RADIAL ENGINE:** An engine construction wherein the cylinders are mounted in a row or circle around the crankcase.

**RADIATION:** The transfer of heat by rays, such as heat from the sun.

**RATIO:** The relation or proportion that one number bears to another.

**REAM:** To finish a hole accurately with a rotating fluted tool.

**RECIPROCATING:** A back and forth movement, such as the action of a piston in a cylinder.

**RECTIFIER:** An electrical device for transforming or changing alternating current into direct current.

**REGULATOR:** An automatic pressure reducing or regulating valve.

**RELAY:** A device for interrupting an electrical circuit; often automatic and may be known as "circuit breaker," "interrupter," "contact breaker," or "cut-out."

**RELIEF:** The amount one surface is set below or above another surface.

**RESISTANCE (ELECTRICAL):** The property of a substance which enables it to resist the flow of an electric current through it.

**RESISTANCE (MECHANICAL):** An opposing or retarding force.

**RESISTOR:** A current consuming piece of metal wire or carbon inserted into an electrical circuit to decrease the flow.

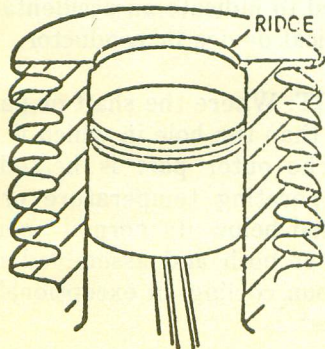

RIDGE

**RETARD:** When used with reference to an ignition distributor, means to cause the spark to occur at a later time in the cycle of engine operation; opposite of spark advance.

**RIDGE:** A narrow, raised rib or strip.

**RIVET:** To attach with rivets or to batter or upset the end of a pin.

**ROCKER ARM:** In an engine a lever located on a fulcrum or shaft, one end of the lever being on the valve stem; the other being on the push rod.

**ROCKWELL HARDNESS:** A scale for designating the degree of hardness possessed by a substance.

**ROLLER BEARING:** An inner and outer race upon which hardened steel rollers operate.

**ROTARY VALVE:** A valve construction in which ported holes come into and out of register with each other to allow entrance and exit of fluids or gases.

**R.P.M.:** Revolutions per minute.

**RUBBER:** An elastic vibration absorbing material of either natural or synthetic origin.

**RUNNING-FIT:** Where sufficient clearance has been allowed between the shaft and journal to allow free running without overheating.

**SAE:** Society of Automotive Engineers.

**SAE STEELS:** A numerical index system used to identify composition of SAE steel. Basically the first digit indicating the type to which the steel belongs; thus (1) indicates a carbon steel, (2) a nickel steel, etc. The second digit generally indicates the approximate percentage of the predominant alloying element. Usually the last two or three digits indicate the approximate average carbon content in points of hundredths of 1 per cent. Thus (SAE 2340 steel) indicates a nickel steel of approximately 3 per cent nickel and 40 per cent carbon.

**SAE THREAD:** Refers to a table of threads set up by the Society of Automotive Engineers and determines the number of threads per inch. For example, a quarter inch diameter rod with an SAE thread would have 28 threads per inch.

**SAFETY FACTOR:** The degree of surplus strength over and above normal requirements which serves as an insurance against failure.

**SAFETY RELIEF VALVE:** A spring loaded valve designed to open and thus relieve excessive pressure in a vessel when it exceeds a pre-determined safe point.

**SAND BLAST:** To clean a surface by means of sand propelled by compressed air.

**SAYBOLT TEST:** A method of measuring the viscosity of oil with the use of a viscosimeter.

**SCALE:** A flaky deposit occurring on steel or iron. Ordinarily used to describe the accumulation of minerals and metals accumulating in a cooling system.

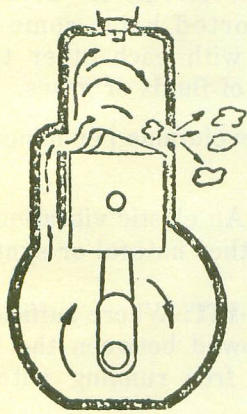

SCAVENGE

**SCAVENGE:** The driving of hot burned exhaust gases from the cylinder through the exhaust port.

**SCORING:** The scratches or grooves on a surface in the direction of the part moving against it.

**SEAT:** A surface, usually machined, upon which another part rests or seats; for example, the surface upon which a valve face rests.

**SECONDARY WINDING:** In an ignition coil or magneto armature, a wire in which a secondary or high tension current is created by induction due to the interruption of the current in the adjacent primary winding.

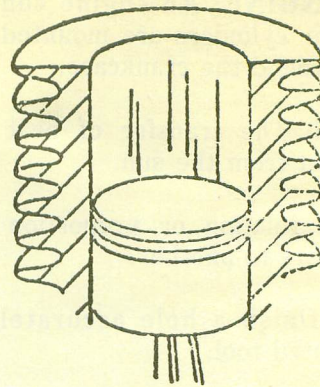

SCORING

**SEDIMENT:** In a fluid this refers to the material which is heaviest and gradually settles to the bottom and accumulates at the bottom of the container.

**SEIZE:** When one surface moving upon another scratches, it is said to seize. An example is a piston score or abrasion in a cylinder due to lack of lubrication or over-expansion.

**SERIES WINDING:** An electric winding or coil of wire in series with other electrical equipment. When applied to electric generators or motors, the field coil is connected in series with the armature.

**“SHAVE”:** See Mill.

**SHEAR:** To cut between two blades.

**SHIM:** Thin sheets used as spacers between two parts, such as the two halves of a journal bearing.

**SHORT CIRCUIT:** To provide a shorter path; often used to indicate an accidental ground in an electrical device or conductor.

**SHRINK-FIT:** Where the shaft or part is slightly larger than the hole in which it is to be inserted. The outer part is heated above its normal operating temperature or the inner part chilled below its normal operating temperature or both and assembled in this condition; upon cooling an exceptionally tight fit is obtained.

**SHUNT:** To by-pass around or turn aside; in electrical apparatus an alternate path for the current.

**SHUNT WINDING:** An electric winding or coil of wire, which forms a bypass or alternate path for electric current. When applied to electric generators or motors, each end of the field winding is connected to an armature brush.

**SILICON STEEL:** An alloy of silicon and chromium with steel. As this alloy resists burning and oxidation and does not warp readily, it is often used for exhaust valves of internal combustion engines.

**SILVER SOLDERING:** Same as Hard Soldering.

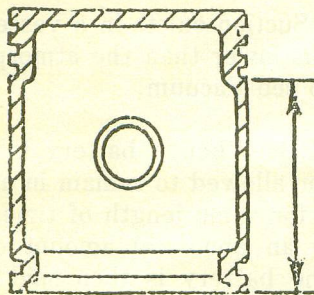

SKIRT

**SKIRT:** The lower, hollow part of the piston.

**SLEEVE:** A hard, cylindrical insert usually installed to increase the life of a part or to provide a wear surface.

**SLIDING-FIT:** Where sufficient clearance has been allowed between the shaft and journal to allow free running without overheating.

**SLIP-IN BEARING:** A liner made to extremely accurate measurements which can be used for replacement purposes without additional fitting.

**SLUDGE:** Indicates a composition of oxidized petroleum products along with an emulsion formed by the mixture of oil and water. This forms a pasty substance and clogs oil lines and passages and interferes with engine lubrication.

**SOLDER:** An alloy of lead and tin used to unite two metal parts.

**SOLDERING:** To unite two pieces of metal with a material, such as solder having a comparatively low melting point.

**SOLENOID:** An iron core surrounded by a coil of wire which moves due to magnetic attraction when an electrical current is fed to the coil; often used to actuate mechanisms by electrical means.

**SOLVENT:** A solution which dissolves some other material. For example, water is a solvent for sugar.

**SOUTH POLE:** The pole of a magnet to which the lines of force flow; the opposite of north pole.

**SPARK:** An electrical current possessing sufficient pressure to jump through the air from one conductor to another.

**SPARK ADVANCE:** When used with reference to an ignition distributor, means to cause the spark to occur at an earlier time in the cycle of engine operation; opposite of retard.

**SPARK KNOCK:** Same as Pre-ignition.

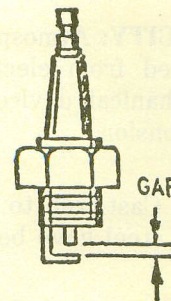

SPARK GAP

**SPARK PLUG:** A device inserted into the combustion chamber of an engine containing an insulated central electrode for conducting the high tension current from the ignition distributor or magneto. This insulated electrode is spaced a pre-determined distance from the shell or side electrode in order to control the dimensions of the gap for the spark to jump across.

**SPECIFIC GRAVITY:** The relative weight of a substance as compared to water. For example, if a cubic inch of acid weighs twice as much as a cubic inch of water, the specific gravity of the substance would be 2.

**SPIRAL BEVEL GEAR:** A gear and pinion wherein the mating teeth are curved and placed at an angle with pinion shaft.

**SPLINE:** A long keyway.

**SPLINE JOINT:** Two mating parts each with a series of splines around their circumference, one inner and one outer in order to provide a longitudinally movable joint without circumferential motion.

**SPOT WELD:** To attach in spots by localized fusion of the metal parts with the aid of an electric current.

**SPRAG CLUTCH:** A clutch that permits turning in one direction or permits one part to turn but automatically disengages when the driven part attempts to turn the driving part.

**SPUR GEAR:** A gear in which the teeth are cut parallel to the shaft.

**STAMPING:** A piece of sheet metal cut and formed into the desired shape with the use of dies.

**STATOR:** The non-moving part, such as the stationary part of the magneto.

**STATIC ELECTRICITY:** Atmospheric electricity as distinguished from electricity as produced by a mechanical device. Usually has extremely high tension.

**STEEL CASTING:** Cast iron to which varying amounts of scrap steel have been added.

**STELLITE:** An alloy of cobalt, chrome and tungsten which is often used for exhaust valve seat inserts. It has a high melting point, good corrosion resistance and unusual hardness when hot.

**STRESS:** The force or strain to which a material is subjected.

**STROBOSCOPE:** A term applied to an ignition timing light which gives the effect of making a marking on a rapidly rotating wheel, such as a flywheel, appear to stand still for observation.

**STROKE:** The length of piston travel in a cylinder.

**"STROKING":** As applied to racing engines, re-machining the crankshaft throws off center to alter the stroke.

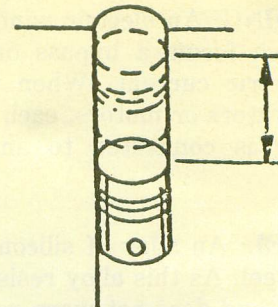

STROKE

**STUDS:** A rod with threads cut on both ends, such as a cylinder stud which screws into the cylinder block on one end and has a nut placed on the other end to hold the cylinder head in place.

**SUCTION:** Suction exists in a vessel when the pressure is lower than the atmospheric pressure; also see Vacuum.

**SULPHATED:** When a battery is improperly charged or allowed to remain in a discharged condition for some length of time, the plates will have an abnormal amount of lead sulphate. The battery is then said to be "sulphated".

**SUPERCHARGER:** A blower or pump which forces air into the cylinders at higher than atmospheric pressure. In an engine the increased pressure forces more air into the cylinder, thus enabling more gasoline to be burned and more power produced.

**SWEAT:** To join metal pieces by clamping together with solder between them and applying heat.

**SYNCHRONIZE:** To cause two events to occur at the same time.

**TACHOMETER:** A device for measuring and indicating the rotative speed of an engine.

**TAP:** To cut threads in a hole with a tapered, fluted, threaded tool.

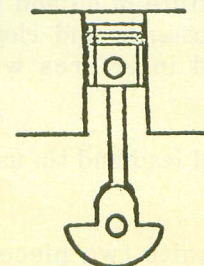

TOP-DEAD-CENTER

**T.D.C.:** Top dead center.

**TEMPER:** To change the physical characteristics of metal by the application of heat.

**TENSION:** Effort devoted towards elongation or "stretching" of a material.

**TERMINAL:** In electrical work, a junction point where connections are made, such as the terminal fitting on the end of a wire.

**T-HEAD ENGINE:** An engine design wherein the inlet valves are placed on one side of the cylinder and the exhaust valves placed on the other.

**THERMAL EFFICIENCY:** A gallon of fuel contains a certain amount of potential energy in the form of heat when burned in the combustion chamber. Some of this heat is lost and some is converted into power. The thermal efficiency is the ratio of work accomplished compared to the total quantity of heat contained in the fuel.

**THERMOSTAT:** A heat controlled valve used in the cooling system of an engine to regulate the flow of water or used in the electrical circuit to control the current.

**THERMO-SYPHON:** A method of cooling an engine which utilizes the difference in specific gravity of hot and cold water. No pump is used, but the water passages are larger than in the pump circulation system.

**THIRD BRUSH:** As used on generators, this is an auxiliary brush placed on the commutator in such relation to the main brushes that it serves to control the current output of the generator.

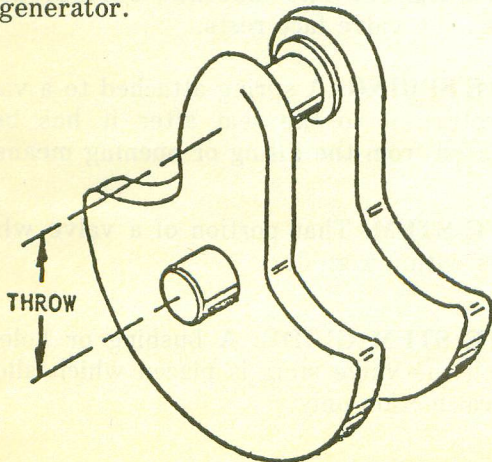

THROW

**THROW:** With reference to an engine, usually the distance from the center of the crankshaft main bearing to the center of the connecting rod journal.

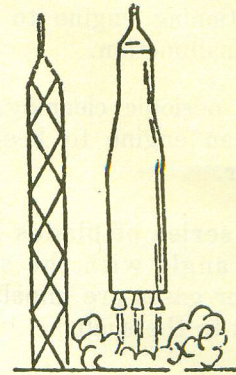

THRUST

**THRUST:** A force directed along the axis of a part.

**TIMER:** Refers to the ignition distributor which times or supplies a spark to the spark plugs at the proper instant.

**TIMING CHAIN:** Chain used to drive camshaft and accessory shafts of an engine.

**TIMING GEARS:** Any group of gears which are driven from the engine crankshaft to cause the valves, ignition and other engine driven apparatus to operate at the desired time during the engine cycle.

**TOLERANCE:** A permissible variation between the two extremes of a specification of dimensions.



TORQUE

**TORQUE:** An effort devoted toward twisting (turning) or rotary motion.

**TORQUE WRENCH:** A special wrench with a built-in indicator to measure the applied force.

**TRANSFORMER:** An electrical device, such as a high tension coil which transforms or changes the characteristics of an electrical current.

**TROUBLE SHOOTING:** The methodical check of a malfunctioning engine to discover the cause of the malfunction.

**TUNE-UP** The periodic cleaning, testing and adjusting of an engine to keep it in good working order.

**TURBINE:** A series of blades located on a wheel at an angle with the shaft against which fluids or gases are impelled to impart rotary motion to the shaft.

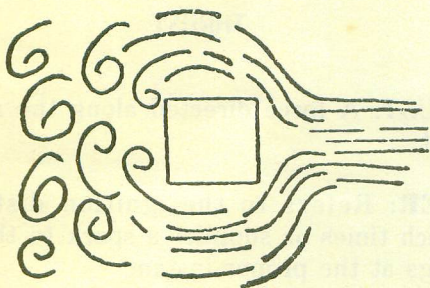

TURBULENCE

**TURBULENCE:** An agitation or disturbance in the normal flow pattern. Irregular motion of fluids or gases.

**TWO-STROKE ENGINE:** An engine design permitting a power stroke once for each revolution of the crankshaft.

**UNIVERSAL JOINT:** A connection for transmitting power from a driving to a driven shaft through an angle.

**UPSET:** To compress endwise causing an increase in diameter.

**VACUUM:** A space completely without matter. A vacuum exists where there is absolutely no pressure. In connection with a gasoline engine this word is used to define a pressure less than atmospheric pressure. The vacuum in a cylinder means suction.

**VACUUM GAGE:** An instrument designed to measure the degree of vacuum existing in a chamber.

**VALVE:** Used in great variety and of many types. A valve is a device which regulates flow.

**VALVE CLEARANCE:** The air gap allowed between the end of the valve stem and the valve lifter or rocker arm to compensate for expansion due to heat.

**VALVE FACE:** That part of a valve which mates with and rests upon a seating surface.

**VALVE GRINDING:** The process of mating the valve seat and valve face usually performed with the aid of an abrasive.

**VALVE GUIDE:** See Valve Stem Guide.

**VALVE HEAD:** The portion of the valve upon which the valve face is machined.

**VALVE-IN-HEAD ENGINE:** Same as overhead valve engine.

**VALVE KEY, KEEPER OR VALVE LOCK:** The key, washer, or other device which holds the valve spring cup or washer in place on the valve stem.

**VALVE LIFTER:** See Cam Follower.

**VALVE MARGIN:** On a poppet valve, the space or rim between the surface of the head and the surface of the valve face.

**VALVE OVERLAP:** An interval expressed in degrees where both valves of an engine cylinder are open at the same time.

**VALVE SEAT:** The matched surface upon which the valve face rests.

**VALVE SPRING:** A spring attached to a valve to return it to the seat after it has been released from the lifting or opening means.

**VALVE STEM:** That portion of a valve which rests within a guide.

**VALVE STEM GUIDE:** A bushing or hole in which the valve stem is placed which allows lateral motion only.

**VANES:** Any plate, blade or the like attached to an axis and moved by or in air or a liquid.